

GOLDEN SCAN "2"

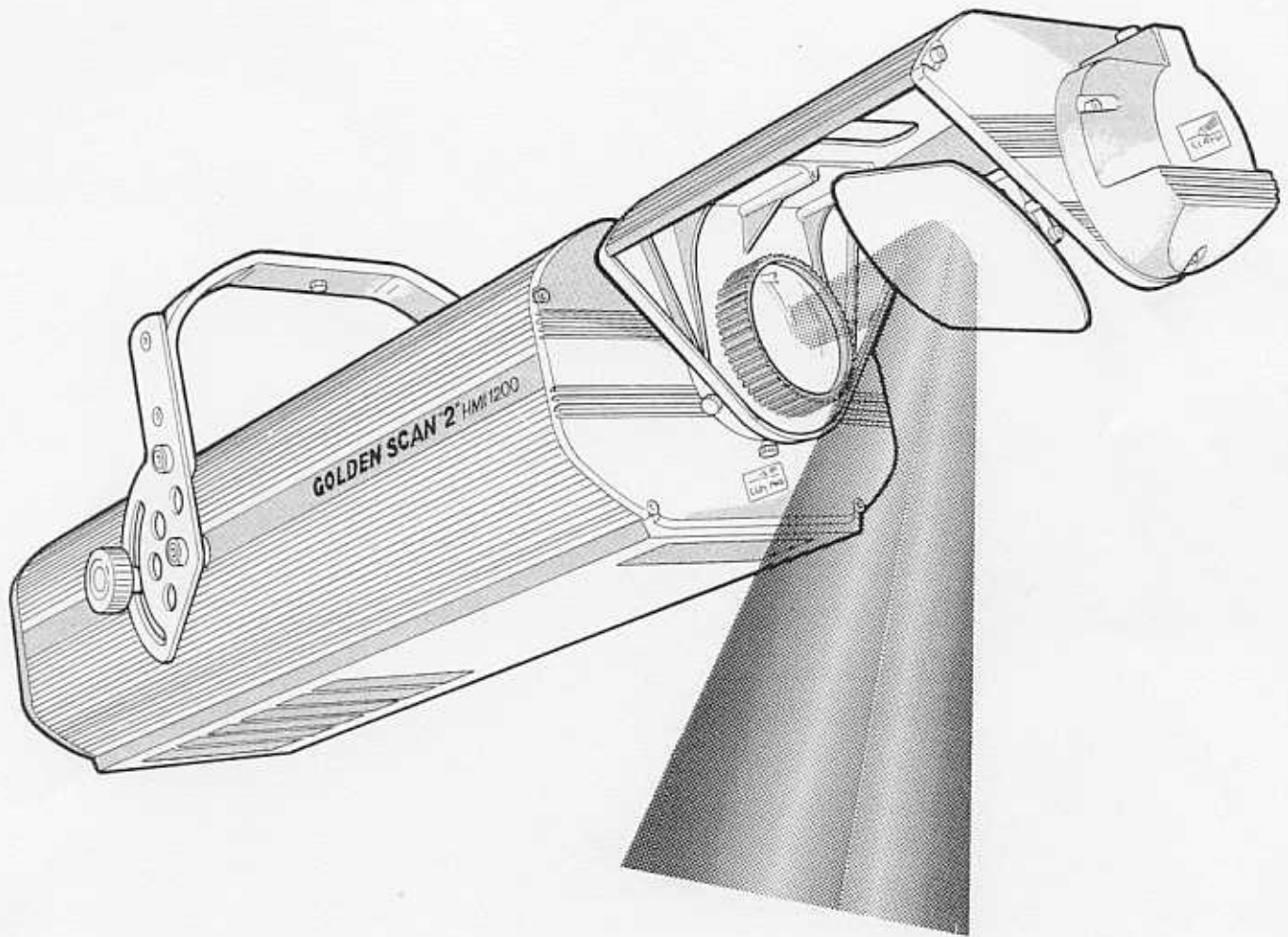

HMI 575
HMI 1200



INSTRUCTION MANUAL

THE GOLDEN SCAN "2" SPOTLIGHT

Golden Scan "2" is a sophisticated spotlight which, by using an up-to-date motor-driven mirror system, enables choreographers and operators to create complex lighting effects.

It uses the most advanced mechanical and electronic technology; as a matter of fact, microprocessor based microstepping motors guarantee a great operational accuracy as well as considerable reliability.

Through technology, it is possible to multiply the effects produced by the ray of light; its movement is smooth and continuous; positioning of the projection is extremely accurate.

The Golden Scan "2" enables the following lighting effects to be obtained:

Colours

- Eight different colours (yellow, red, orange, green, blue, violet, pink, white).
- Possibility of bi-colour rays (obtained through the intermediate positions of the colour disk).
- Change of colours with fixed positions or continuous.
- Rainbow effect obtained by the continuous rotation of the colour disk.

Images (Gobos)

- Eight basic gobos.
- Eight composite images, to be obtained by superimposing the basic gobos.
- Possibility of moving two superposed gobos one over the other, thus creating an oscillating effect.

Projection of light

- Iris, to vary the amplitude of the projected ray, at will.
- Black-out, to instantaneously stop the output of the light beam.
- Strobe effect, with adjustable frequency from 1 to 7 flashes per second.

This manual is a simple but clear guide which will enable you to make the most of the above functions. It also provides the necessary instructions for correct installation and maintenance of the device.

OVERALL DIMENSIONS (mm)

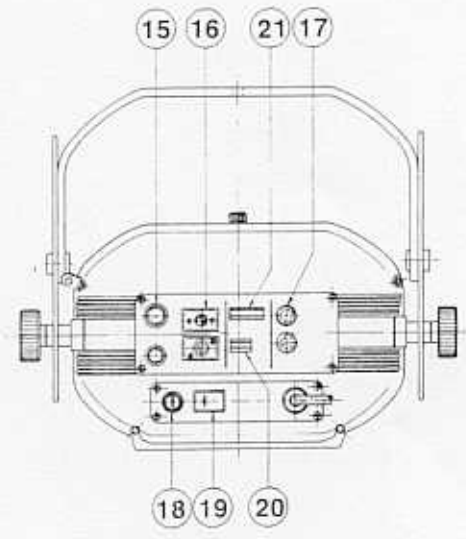
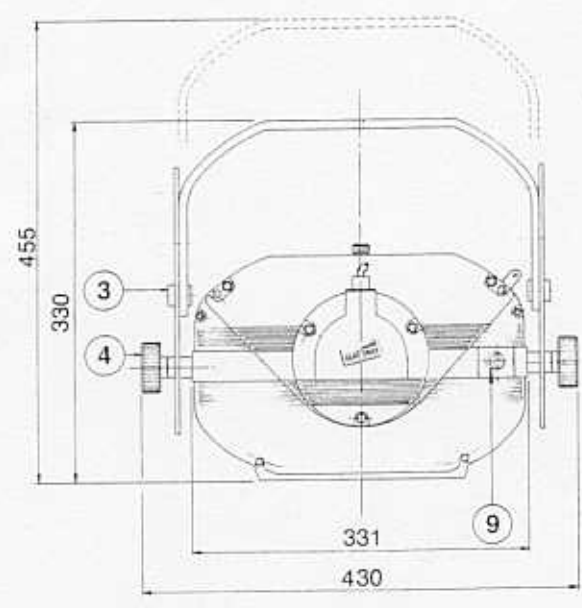
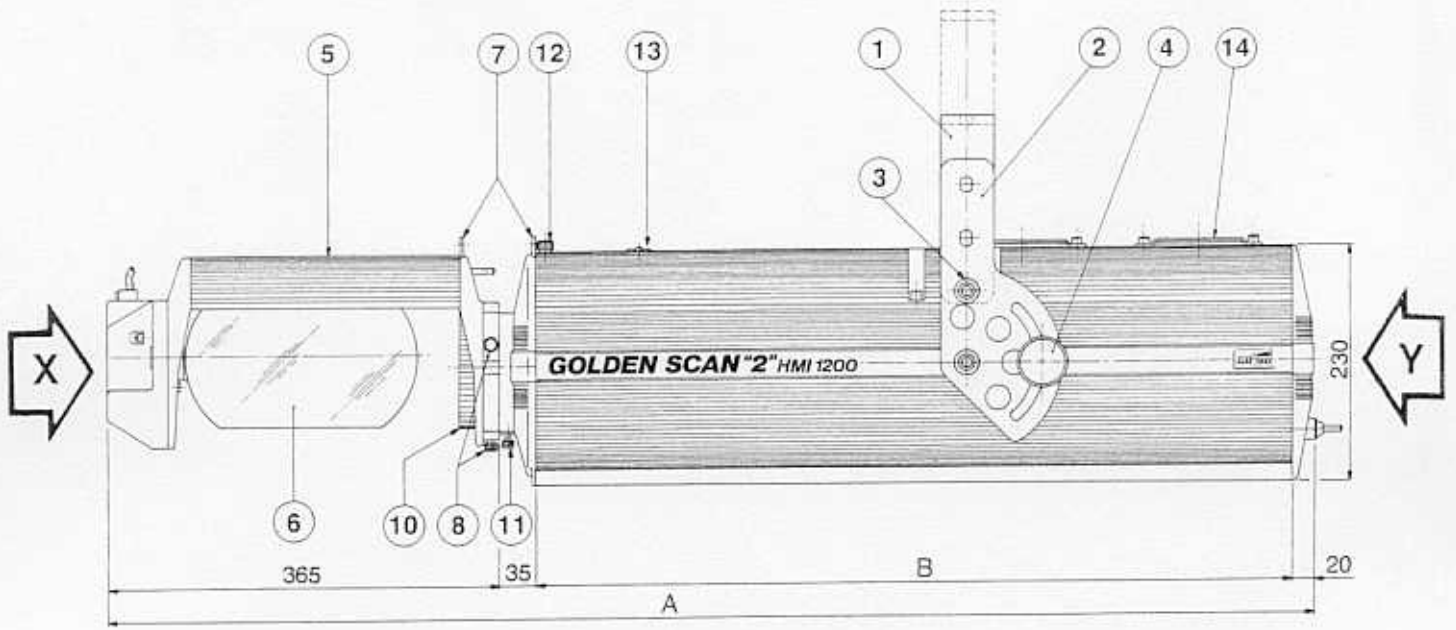

Type	A	B
GOLDEN SCAN "2" HMI 575	1015	595
GOLDEN SCAN "2" HMI 1200	1140	720

CONTROLS AND PARTS REFERENCES

- 1 - Spotlight bracket
- 2 - Angular adjustment plate
- 3 - Vertical adjustment holes
- 4 - Locking knob
- 5 - Mirror unit
- 6 - Mirror
- 7 - Mirror unit safety chain fixing point
- 8 - Mirror unit locking screw
- 9 - Mirror unit output socket
- 10 - Objective lens
- 11 - Objective lens locking screw
- 12 - Top cover locking screw
- 13 - Door for lamp replacement and cleaning
- 14 - Fan grill
- 15 - RS 232 input/output socket
- 16 - DMX 512 input/output socket
- 17 - 0 ÷ 10 V analogue signal input/output socket
- 18 - Fuse
- 19 - Mains switch
- 20 - Option select microswitches
- 21 - Digital start address select

INDEX

1. INSTALLATION OF SPOTLIGHT	pag. 6
• Unpacking.....	» 6
• Assembly and setting of spotlight.....	» 6
• Lamp fixing	» 6
• Spotlight fixing	» 7
2. INSTALLATION OF MIRROR UNIT	» 7
• Unpacking.....	» 7
• Assembly of mirror unit.....	» 7
3. CONNECTIONS AND SETTING UP	» 8
• Connection to the mains and power consumption	» 8
• Connection of control signals (0 ÷ 10 V - RS 232 - DMX 512).....	» 9
• Projector coding (for digital signals)	» 10
4. FOCUS ADJUSTMENT	» 11
• Projector inclination.....	» 11
• Mirror unit adjustment	» 11
• Objective lens adjustment	» 11
5. CHANNELS FUNCTION AND OPTIONS	» 12
• Iris	» 12
• Colour change.....	» 12-13
• Gobos	» 14
• Strobe.....	» 15
• Mirror (vertical and horizontal movements).....	» 15
6. OBJECTIVE LENS	» 16-17-18
7. MAINTENANCE	» 19
• Projector opening	» 19
• Lamp replacement	» 19
• Replacement of dichroic filters.....	» 19
• Gobos replacement	» 19
• Starter replacement.....	» 20
• Fuse replacement	» 20
• Periodic cleaning.....	» 20
8. TECHNICAL DATA	» 21
9. SPARE PARTS AND OPTIONAL ITEMS	» 22
10. REMEDIES FOR EVENTUAL OPERATION ANOMALIES	» 23

Nota: all numerical references made in text apply also to the figure shown on the back of the cover page (page 3).

1. INSTALLATION OF SPOTLIGHT

• Unpacking

Open the carton, take the projector out of its packing and place it on a horizontal supporting surface. Remove the spotlight bracket (1) and the components which are contained in a bag placed in the packing.

• Assembly and setting of spotlight

Fit the spotlight bracket (1) to the angular adjustment plate (2) according to the required height. Insert the bush, washer and screw (3) into the selected vertical adjustment hole and tighten by means of the supplied Allen wrench.

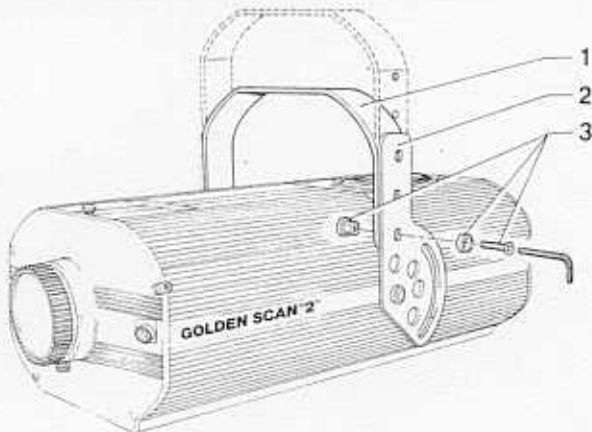

Mount the locking knob, the washer and the spacer (4) and lock the spotlight bracket in the required position. Remove the blocks and the protection envelope.

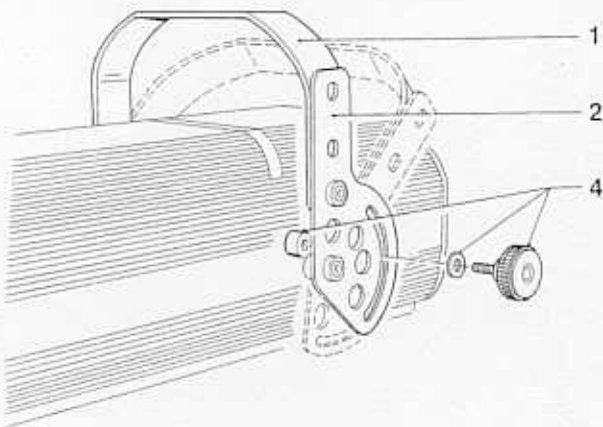

The spotlight bracket can also be mounted facing downwards by inverting the angular adjustment plate (2). Also in this case, follow the above described procedure to mount the spotlight bracket (1).

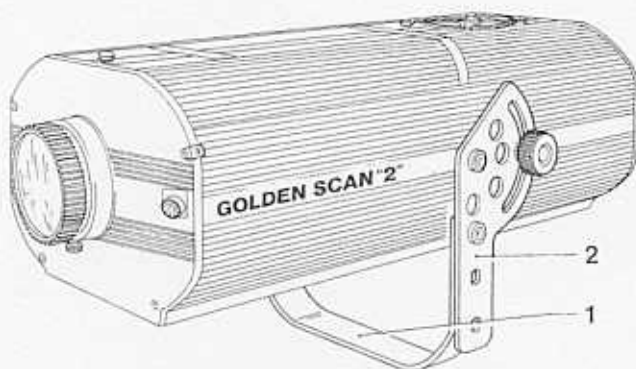

• Lamp fixing

Loosen the top cover locking screw (12) and remove the lamp replacement and cleaning door (13) from the projector.

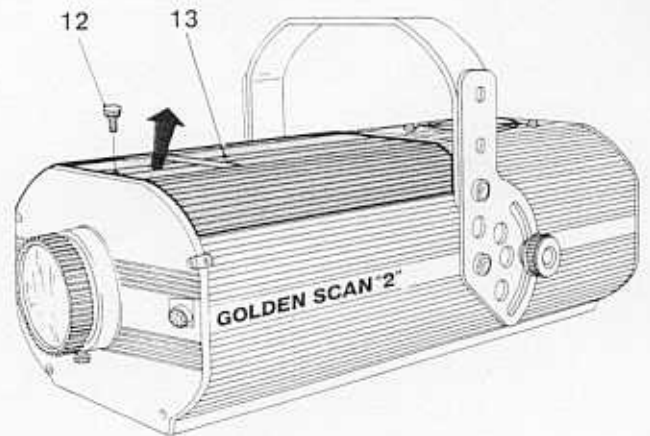

Take out the new lamp from its packaging and carefully read the enclosed "instructions for use".

METALLOGEN®
HMI 1200 W/GS
HMI 575 W/GS

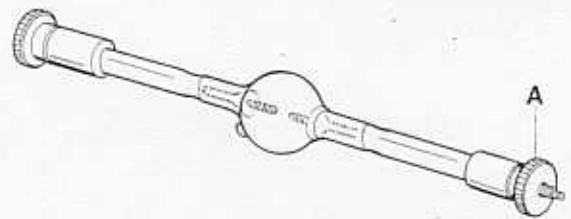

Loosen the two side knurled nuts (A) and insert the lamp into the lamp holders (B).

IMPORTANT: to get an even distribution of the light beam, the lamp should be so positioned that the bump (C) in quartz bulb is pointing downwards. Lock the lamp by the two knurled nuts (A); refit and lock the door (13) by means of the top cover locking screw (12).

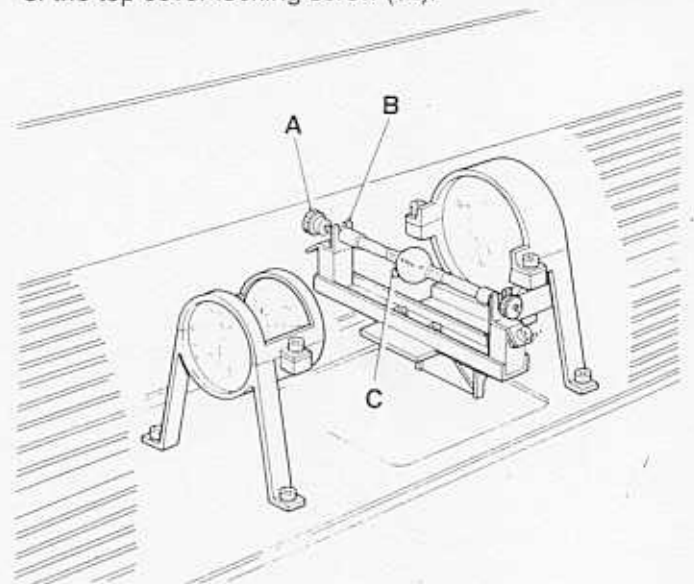

• Spotlight fixing

The spotlight may be positioned in any position whatsoever (see examples) and still maintain its operating features unchanged.

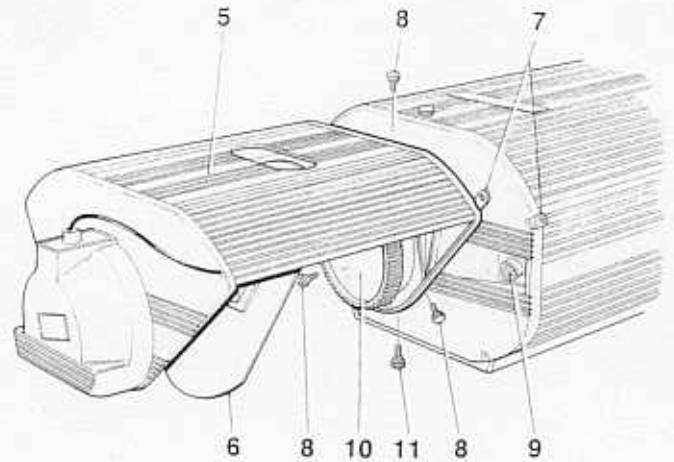
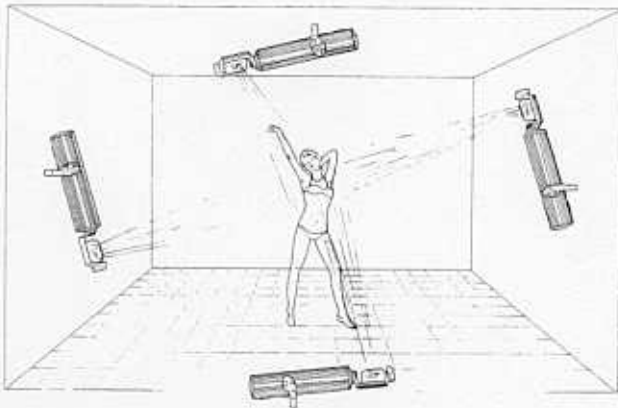

N.B. - For Added Safety the use of a 2.5 \varnothing wire rope is recommended to secure the mirror unit (5) to the spotlight by means the safety chain fixing points located on the respective bodies (7).

It is however absolutely necessary to follow the accident prevention Standards effective in the installation Country.

IMPORTANT: fix the spotlight in the required position by means of the hole provided in the spotlight bracket. The use of a 10 \varnothing screw complete with nut and washer is recommended.

Make sure of the fixing point stability before positioning the spotlight.

2. INSTALLATION OF MIRROR UNIT

• Unpacking

After opening the carton, take out the mirror unit and place it on a horizontal supporting surface. Remove the blocks and the protection envelope.

• Mirror unit assembly

Loosen the objective lens locking screw (11) and pull off the objective lens (10) from the spotlight.

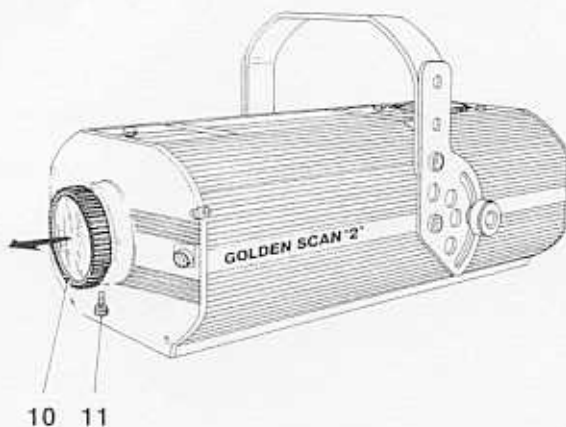

Assemble the mirror unit (5) to the spotlight and fix it by means of the three mirror unit locking screw (8). Move the mirror (6) to the vertical position. Insert the objective lens (10) and lock by means of the objective lens locking screw (11). Plug the mirror unit into the output socket located in the spotlight body (9).

3. CONNECTIONS AND SETTING UP

- Connection to the mains

The projector must be fed with voltage / frequency as shown on the projector back.

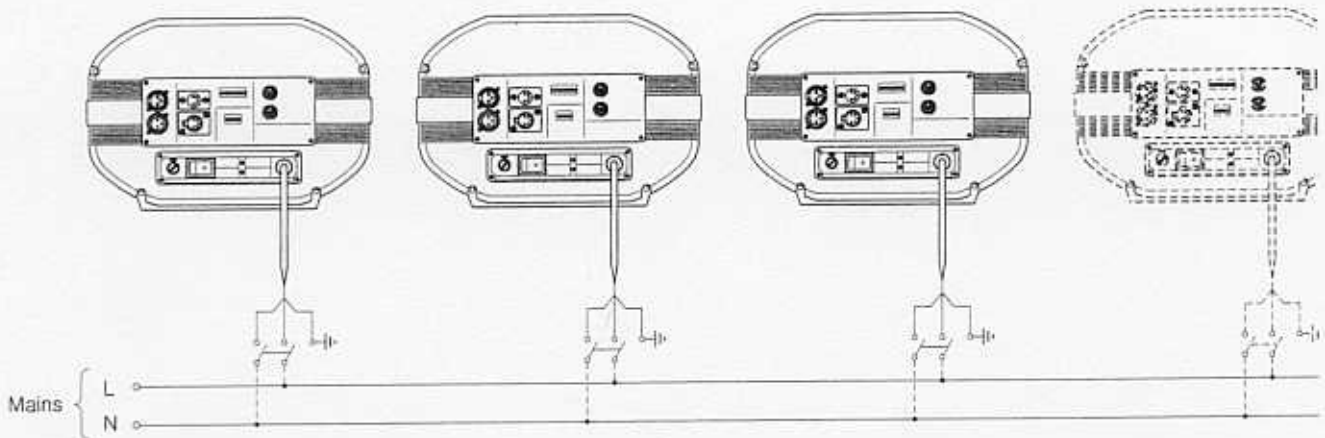

It is advisable to connect each unit through its own mains switch, so that each can be switched off individually.

- Important: it is compulsory that every spotlight be earthed in compliance with the applicable Standards.

After carrying out all above described operations, press the mains switch (Pos. 19) checking that the pilot lamp is lighted and the automatic reset procedure has begun.

METAL HALIDE DISCHARGE LAMP	ABSORBED POWER V.A. with 220 Vac.		
	WITH POWER FACTOR CORRECTION		WITHOUT POWER FACTOR CORRECTION
	VA	uF	VA
HMI 575 W/GS	750	80	1500
HMI 1200 W/GS	1500	160	3100

• Connection of control signals

0 - 10V CONNECTION

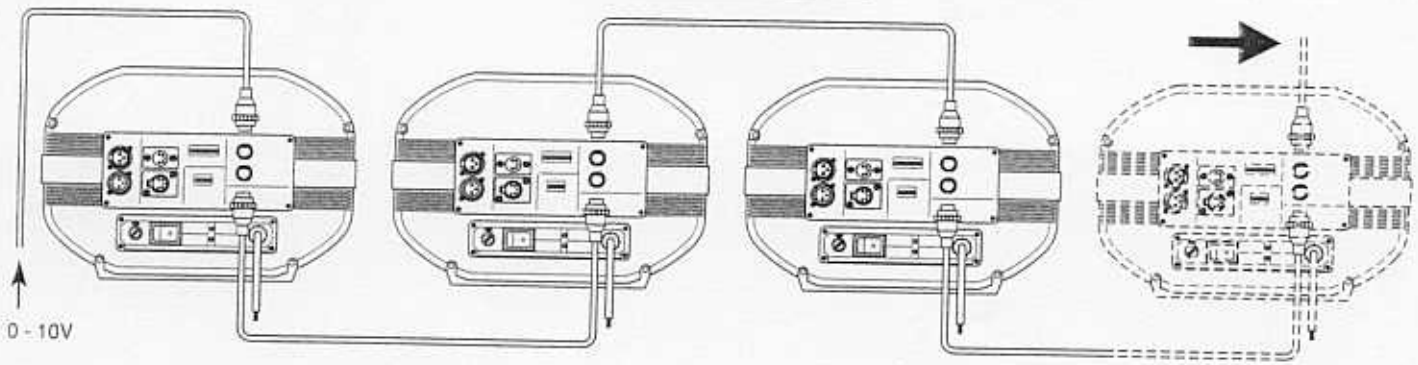

Connection between computer and spotlight, and between spotlight and spotlight, must be carried out by a multi-wire cable consisting of 8 wires having 0.25mm² section and plug - socket DIN 8PIN 45°.

RS 232 CONNECTION

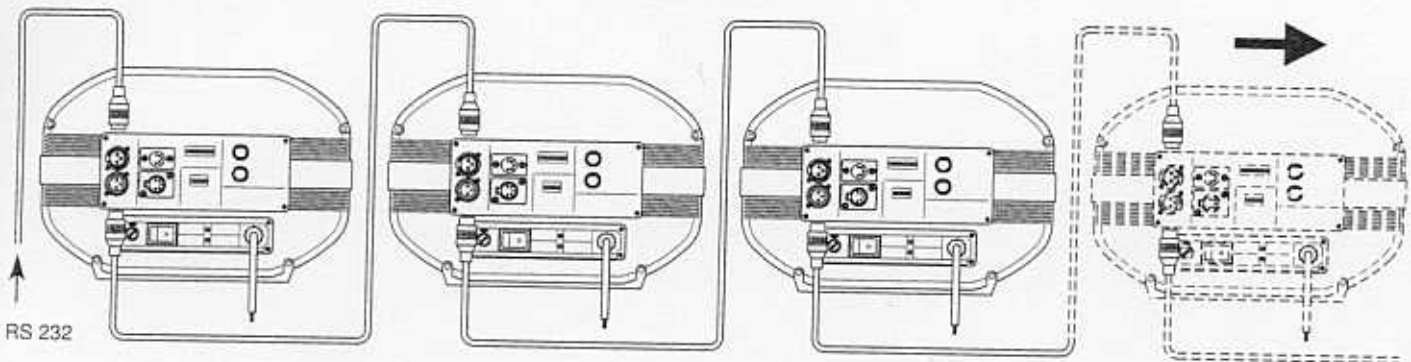

Connection between computer and spotlight, and between spotlight and spotlight, must be carried out by a RG 58 or RG 59 type coaxial cable. Plugs - sockets Cannon type 3PIN XLR.

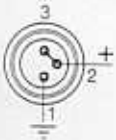

It is important that the wires do not touch one another or the plug metal envelope. The plug envelope should not be connected to anything.

DMX 512 CONNECTION

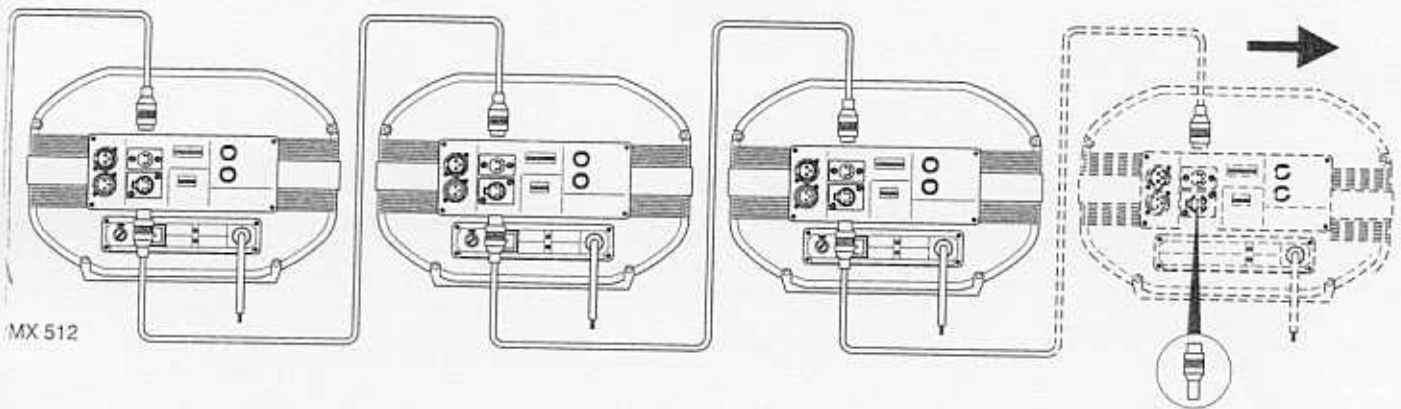

Connection between computer and spotlight, and between spotlight and spotlight, must be carried out by a shielded 5-pole cable. Plugs - sockets Cannon type 5PIN XLR. On the last spotlight of the line a DMX terminator must be plugged in.

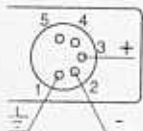

It is important that the wires do not touch one another or the plug metal envelope. The plug envelope should not be connected to anything.

• Spotlight coding (for digital signals)

Every GOLDEN SCAN 2 needs 6 control channels.

To enable the control signals are correctly addressed to each spotlight, it is necessary to properly code the spotlight. The coding operation must be performed on every single GOLDEN SCAN 2 by setting the micro-switches according to the table below.

DIGITAL START ADDRESS SELECT (Pos.21)

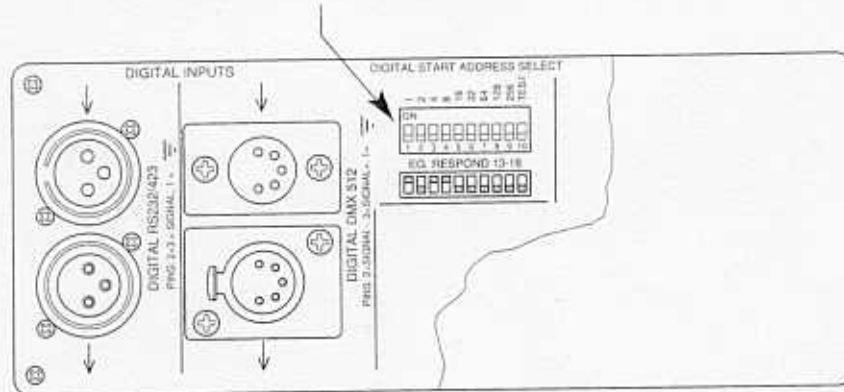

CODING		1	2	4	8	16	32	64	128	256	TEST
Projector 1- Channels 1-6	ON	▲	▼	▼	▼	▼	▼	▼	▼	▼	▼
	OFF	▼	▼	▼	▼	▼	▼	▼	▼	▼	▼
Projector 2- Channels 7-12	ON	▲	▲	▲	▼	▼	▼	▼	▼	▼	▼
	OFF	▼	▼	▼	▼	▼	▼	▼	▼	▼	▼
Projector 3- Channels 13-18	ON	▲	▼	▲	▲	▼	▼	▼	▼	▼	▼
	OFF	▼	▼	▼	▼	▼	▼	▼	▼	▼	▼
Projector 4- Channels 19-24	ON	▲	▲	▼	▼	▲	▼	▼	▼	▼	▼
	OFF	▼	▼	▼	▼	▼	▼	▼	▼	▼	▼
Projector 5- Channels 25-30	ON	▲	▼	▼	▲	▲	▼	▼	▼	▼	▼
	OFF	▼	▼	▼	▼	▼	▼	▼	▼	▼	▼
Projector 6- Channels 31-36	ON	▲	▲	▲	▲	▲	▼	▼	▼	▼	▼
	OFF	▼	▼	▼	▼	▼	▼	▼	▼	▼	▼
Projector 7- Channels 37-42	ON	▲	▼	▲	▼	▼	▲	▼	▼	▼	▼
	OFF	▼	▼	▼	▼	▼	▼	▼	▼	▼	▼
Projector 8- Channels 43-48	ON	▲	▲	▼	▲	▼	▲	▼	▼	▼	▼
	OFF	▼	▼	▼	▼	▼	▼	▼	▼	▼	▼
Projector 9- Channels 49-54	ON	▲	▼	▼	▼	▲	▲	▼	▼	▼	▼
	OFF	▼	▼	▼	▼	▼	▼	▼	▼	▼	▼
Projector 10- Channels 55-60	ON	▲	▲	▲	▼	▲	▲	▼	▼	▼	▼
	OFF	▼	▼	▼	▼	▼	▼	▼	▼	▼	▼
Projector 11- Channels 61-66	ON	▲	▼	▲	▲	▲	▲	▼	▼	▼	▼
	OFF	▼	▼	▼	▼	▼	▼	▼	▼	▼	▼
Projector 12- Channels 67-72	ON	▲	▲	▼	▼	▼	▼	▲	▼	▼	▼
	OFF	▼	▼	▼	▼	▼	▼	▼	▼	▼	▼
Projector 13- Channels 73-78	ON	▲	▼	▼	▲	▼	▼	▲	▼	▼	▼
	OFF	▼	▼	▼	▼	▼	▼	▼	▼	▼	▼
Projector 14- Channels 79-84	ON	▲	▲	▲	▲	▼	▼	▲	▼	▼	▼
	OFF	▼	▼	▼	▼	▼	▼	▼	▼	▼	▼
Projector 15- Channels 85-90	ON	▲	▼	▲	▼	▲	▼	▲	▼	▼	▼
	OFF	▼	▼	▼	▼	▼	▼	▼	▼	▼	▼
Projector 16- Channels 91-96	ON	▲	▲	▼	▲	▲	▼	▲	▼	▼	▼
	OFF	▼	▼	▼	▼	▼	▼	▼	▼	▼	▼
Projector 17- Channels 97-102	ON	▲	▼	▼	▼	▼	▲	▲	▼	▼	▼
	OFF	▼	▼	▼	▼	▼	▼	▼	▼	▼	▼
Projector 18- Channels 103-108	ON	▲	▲	▲	▼	▼	▲	▲	▼	▼	▼
	OFF	▼	▼	▼	▼	▼	▼	▼	▼	▼	▼
Projector 19- Channels 109-114	ON	▲	▼	▲	▲	▼	▲	▲	▼	▼	▼
	OFF	▼	▼	▼	▼	▼	▼	▼	▼	▼	▼
Projector 20- Channels 115-120	ON	▲	▲	▼	▼	▲	▲	▲	▼	▼	▼
	OFF	▼	▼	▼	▼	▼	▼	▼	▼	▼	▼
ON	▲										
OFF	▼										

Move the test switch to ON position for few seconds to get the automatic reset with the spotlight on.
If the test switch is left in ON position, the complete autotest is carried out; after completion of this operation, move the test switch again to OFF position.

4. FOCUS ADJUSTMENT

• Spotlight centering and mirror unit adjustment

To start the spotlight centering, some preparation work must be first carried out.

Arrange the channels as shown in table below:

CHANNEL	POSITION
1 IRIS	Position on 0 of adjustment range (Maximum closing)
2 COLOUR	Position on 0 of adjustment range (White colour)
3 GOBOS	Position on 0 of adjustment range (Without Gobos)
4 STROBE	Position on 100% of adjustment range (Open)
5 PAN	Position on 50% of adjustment range (Central position)
6 TILT	Position on 50% of adjustment range (Central position)

The above operations having been carried out, proceed by moving the spotlight on the bracket (fig. 1) via the locking knob (4). Loosen the locking screws (8). Turn the mirror unit (5) on the spotlight body (fig. 2) until the light beam is focused to the central spot of the show. Lock the knobs (4) and the screws (8).

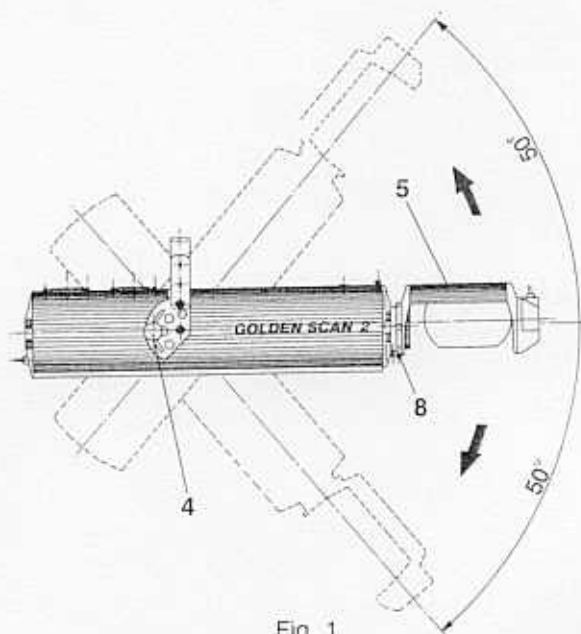

Fig. 1

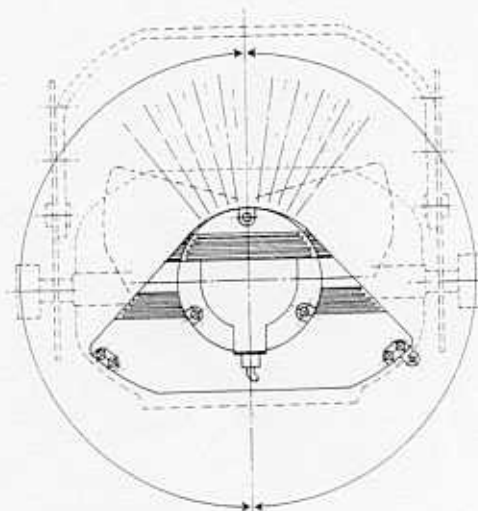
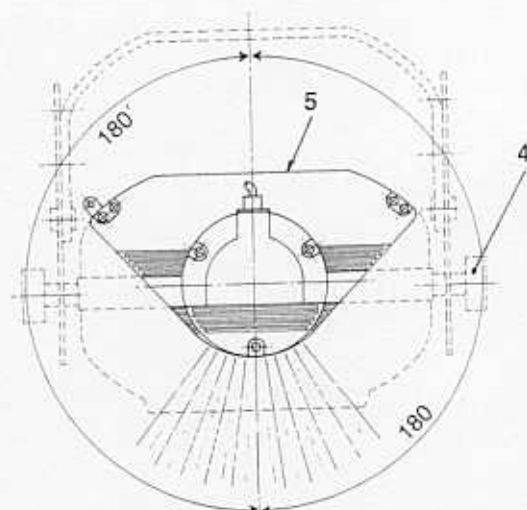

Fig. 2

• Objective lens adjustment

To start the objective lens adjustment, some preparation work must be first carried out.

Arrange the channels as shown in table below: the required operations being carried out, proceed by axially moving the objective lens (10) until the projected image is focused. Lock the objective lens locking screw (11).

CHANNEL	POSITION
1 IRIS	Position on 100% of adjustment range (Maximum aperture)
2 COLOUR	Position on 0 of adjustment range (White colour)
3 GOBOS	Execute the adjustment on the wished Gobo
4 STROBE	Position on 100% of adjustment range (Open)
5 PAN	Position on 50% of adjustment range (Central position)
6 TILT	Position on 50% of adjustment range (Central position)