

VARI***LITE**®

TECHNICAL MANUAL

OPERATOR AND TECHNICAL MAINTENANCE MANUAL

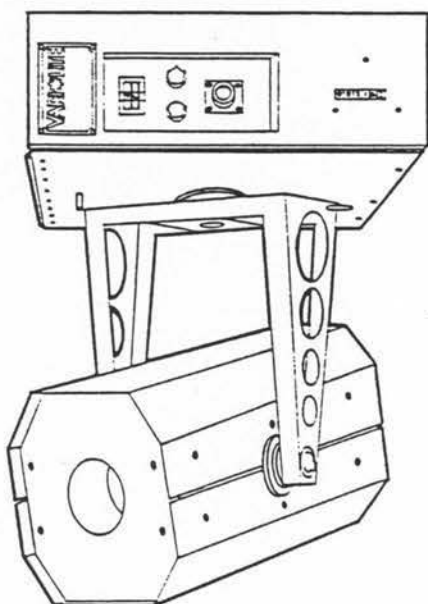

VARILITE* 1**
SPOT LUMINAIRE

Vari-Lite, Inc.
201 Regal Row
Dallas TX 75247

EQUIPMENT DATA	1-4
INSTALLATION	2-6
TROUBLESHOOTING PROCEDURES	2-8
CALIBRATION PROCEDURES	2-25
MAINTENANCE PROCEDURES	2-31
IRIS BULKHEAD ASSEMBLY	2-47
FILTER/FOCAL ASSEMBLY (FFA)	2-53
PAN & TILT ASSEMBLIES	2-60
YOKE AND YOKE CABLE	2-65
STORAGE AND SHIPMENT	2-74
LAMP POWER SUPPLY (LPS)	3-9
ACS RACK AND REPEATER TROUBLESHOOTING	3-22
DELTA-WYE TRANSFORMER	3-27
DIAGRAMS	3-31
ILLUSTRATED PARTS LIST	4-4

SAFETY PRECAUTIONS

WARNING

HIGH VOLTAGE

is used in this equipment

DEATH ON CONTACT

may result if safety precautions
are not observed.

115 volts ac is present within the VARI*LITE luminaire. Perform all possible maintenance with power removed. When necessary to perform maintenance with covers removed and power on, be extremely careful to avoid contact with high voltage.

The Marc 350 lamp operates at 350 watts on a current regulated (7.5A) electronic ballast supply. EXTREME CARE MUST BE TAKEN WHEN RE-LAMPING TO ENSURE LAMP POWER SUPPLY IS OFF. The lamp power supply (LPS) may be on even though the lamp itself is not lit. Be sure the LPS is off.

Lamp end-of-life is sometimes catastrophic. Take care to protect your eyes when performing maintenance with covers removed and lamp lit, in case the bulb explodes. Never look into the light beam.

DON'T TAKE CHANCES

FIRST PRINTING: March 1987.

SECOND PRINTING: January 1988.

Operator and Technical
Maintenance Manual

VARI*LITE 1 SPOT LUMINAIRE

REPORTING ERRORS AND RECOMMENDING IMPROVEMENTS

You can improve this manual. If you find any mistakes, or if you know of a way to improve procedures, please let us know. Mail your letter to Service Manager, Vari-Lite Inc., 201 Regal Row, Dallas TX 75247. A reply will be furnished to you.

NOTICE

● VARI*LITE® is a registered trademark for the automated stage lighting equipment made by Vari-Lite, Inc., 201 Regal Row, Dallas TX 75247.

● This product is protected by U.S. patent no. 4,392,187; Canadian patent no. 1,181,795; and other pending patent applications in the United States and other countries.

CHAPTER 1 INTRODUCTION

Section I GENERAL INFORMATION

<u>Para.</u>	<u>Title</u>	<u>Page No.</u>
1-1.	Scope.....	1-1
1-2.	Variations of Equipment Covered.....	1-1
1-3.	Maintenance Reporting.....	1-2
1-4.	Preparation for Storage or Shipment.....	1-2
1-5.	Safety, Care and Handling.....	1-2

Section II EQUIPMENT DESCRIPTION

1-6.	Characteristics.....	1-3
1-7.	Capabilities and Features.....	1-3
1-8.	Equipment Data.....	1-4
1-9.	Location and Description of Major Components.....	1-5

Section III PRINCIPLES OF OPERATION

1-10.	Operation in the System.....	1-12
1-11.	Operation of Internal Functions.....	1-14

CHAPTER 2 OPERATOR MAINTENANCE INSTRUCTIONS

Section I TOOLS AND EQUIPMENT

<u>Para.</u>	<u>Title</u>	<u>Page No.</u>
2-1.	Common Tools and Equipment.....	2-1
2-2.	Special Tools, Test and Support Equipment.....	2-1
2-3.	Repair Parts.....	2-5

Section II NORMAL OPERATIONS

2-4.	Mounting Requirements.....	2-6
2-5.	Preliminary Settings.....	2-7

Section III PREVENTIVE MAINTENANCE CHECKS AND SERVICES

2-6.	Records.....	2-8
2-7.	Preventive Maintenance.....	2-8

Section IV TROUBLESHOOTING PROCEDURES

2-8.	Troubleshooting Procedure.....	2-8
2-9.	Troubleshooting Chart.....	2-9
2-10.	Test Setup.....	2-14
2-11.	DC Power Supply Checks.....	2-15
2-12.	Servo Power Supply Checks.....	2-15
2-13.	Data Receiver Checks.....	2-17
2-14.	Lamp Power Checks.....	2-19
2-15.	Servo Circuit Checks.....	2-20
2-16.	Iris Assembly Checks.....	2-21
2-17.	Pan System Checks.....	2-22
2-18.	Tilt System Checks.....	2-22
2-19.	Filter/Focal Assembly Checks.....	2-23
2-20.	Erratic Behavior.....	2-24

Section V CALIBRATION PROCEDURES

2-21.	Servo Circuit Calibration.....	2-25
2-22.	Pan/Tilt Calibration.....	2-25
2-23.	Lamp Power Supply Calibration.....	2-26
2-24.	Iris Calibration.....	2-27
2-25.	FFA Calibration.....	2-28
2-26.	Operational Checkout.....	2-29

CHAPTER 2 OPERATOR MAINTENANCE INSTRUCTIONS (CONT'D)

Section VI MAINTENANCE PROCEDURES

<u>Para.</u>	<u>Title</u>	<u>Page No.</u>
2-27.	Transistor Testing.....	2-31
2-28.	Soldering.....	2-33
2-29.	Transistor Replacement.....	2-34
2-30.	DC Power Supply Repair.....	2-36
2-31.	Data Receiver/Servo Power Supply Removal/Installation.....	2-38
2-32.	Data Receiver/Servo Power Supply Repair.....	2-39
2-33.	Head Fan Replacement.....	2-39
2-34.	UPE Fan Replacement.....	2-40
2-35.	Motor Brush Replacement.....	2-41
2-36.	Lamp Replacement.....	2-41
2-37.	Lamp Wire/Connector Replacement.....	2-42
2-38.	Solid-State Relay Replacement.....	2-44
2-39.	Thermal Fuse Replacement.....	2-44
2-40.	Lamp Power Supply Removal/Installation.....	2-45

Section VII IRIS BULKHEAD ASSEMBLY

2-41.	Iris Bulkhead Removal/Installation.....	2-47
2-42.	Iris Motor Replacement.....	2-47
2-43.	Iris Clutch Adjustment.....	2-48
2-44.	Iris Feedback Pot.....	2-49
2-45.	Iris Arm Gear Assembly.....	2-49
2-46.	Iris Leaf Replacement.....	2-50
2-47.	Iris Cleaning and Lubrication.....	2-51
2-48.	POD Replacement.....	2-52

Section VIII FILTER/FOCAL ASSEMBLY

2-49.	FFA Removal/Installation.....	2-53
2-50.	Wheel Motor Replacement.....	2-54
2-51.	Wheel Feedback Pot.....	2-54
2-52.	FFA Disassembly.....	2-55
2-53.	Filter/Beam Wheel Disassembly.....	2-56
2-54.	Filter/Aperture/Gobo Replacement.....	2-57
2-55.	Hub Gear.....	2-59
2-56.	FFA Reassembly.....	2-59

Section IX PAN AND TILT ASSEMBLIES

2-57.	Tilt Bracket Removal/Installation.....	2-60
2-58.	Pan Bracket Removal/Installation.....	2-61
2-59.	Pan/Tilt Motor Replacement.....	2-61
2-60.	Pan/Tilt CLutch Adjustment.....	2-62
2-61.	Pan/Tilt Feedback Pot.....	2-62
2-62.	Pulley Removal/Installation.....	2-62
2-63.	Belt Replacement.....	2-64

CHAPTER 2 OPERATOR MAINTENANCE INSTRUCTIONS (CONT'D)

Section X YOKE AND YOKE CABLE

<u>Para.</u>	<u>Title</u>	<u>Page No.</u>
2-64.	Yoke Removal.....	2-65
2-65.	Yoke Installation.....	2-66
2-66.	Yoke Cable Removal.....	2-67
2-67.	Yoke Cable Installation.....	2-68

Section XI PREPARATION FOR STORAGE AND SHIPMENT

2-68.	Travel Cases.....	2-74
2-69.	Shipping Data.....	2-75

CHAPTER 3 TECHNICAL MAINTENANCE INFORMATION

Section I THEORY OF OPERATION

3-1.	Variable Lighting Instrument.....	3-1
3-2.	Control Signal.....	3-1
3-3.	Data Receiver.....	3-3
3-4.	Servo Circuits.....	3-8
3-5.	Lamp Power Supplies (LPS).....	3-9
3-6.	LPS Controls.....	3-12

Section II ADVANCED TECHNICAL PROCEDURES

3-7.	GE Lamp Power Supply.....	3-16
3-8.	EMI1 Lamp Power Supply.....	3-18
3-9.	EMI2 Lamp Power Supply.....	3-20
3-10.	Trouble With the ACS Rack.....	3-22
3-11.	Trouble With the Repeater.....	3-23
3-12.	Delta/Wye Step-Down Transformer.....	3-26
3-13.	Shop Practices.....	3-28
3-14.	Luminaire Check List.....	3-28
3-15.	Cable Check List.....	3-29
3-16.	ACS Rack Check List.....	3-29
3-17.	Road Case Check List.....	3-29

Section III DIAGRAMS

3-18.	Schematic Diagrams.....	3-30
	DC Power Supply.....	3-31
	Data Receiver.....	3-33
	Servo Power Supply.....	3-37
	GE Lamp Power Supply.....	3-39
	EMI1 Lamp Power Supply.....	3-41
	EMI2 Lamp Power Supply.....	3-43
	Lamp Power Supply Control Board.....	3-45

CHAPTER 3 TECHNICAL MAINTENANCE INFORMATION (CONT'D)

Section III DIAGRAMS (Cont'd)

<u>Para.</u>	<u>Title</u>	<u>Page No.</u>
	Wheel Servo Board.....	3-46
3-19.	Power and Signal Distribution Equipment.....	3-31
	Console Snake.....	3-48
	ACS Rack.....	3-49
	Trunk Cable.....	3-51
	Lamp Cable.....	3-51
	Repeater Card.....	3-53

CHAPTER 4 ILLUSTRATED PARTS BREAKDOWN

Section I INTRODUCTION

4-1.	How to Read the Parts List.....	4-1
4-2.	How to Use the Cross Reference Index.....	4-3

Section II ILLUSTRATED PARTS LIST

4-3.	Head Assembly.....	4-4
4-4.	Yoke Assembly.....	4-6
4-5.	Upper Enclosure.....	4-8
4-6.	Filter/Focal Assembly.....	4-12
4-7.	Iris Bulkhead.....	4-16
4-8.	Pan/Tilt Bracket.....	4-18
4-9.	Circuit Card Assembly, Wheel Servo Board.....	4-20
4-10.	Head Fan Assembly.....	4-29
4-11.	Circuit Card Assembly, Lamp Power Supply..... Control Board	4-30
4-12.	Circuit Card Assembly, Servo Power Supply.....	4-32
4-13.	Circuit Card Assembly, Data Receiver.....	4-37

APPENDIX A	REFERENCES.....	A-1
APPENDIX B	BASIC ITEMS ISSUE LIST.....	B-1
APPENDIX C	COLOR MASTER DISK.....	C-1
APPENDIX D	MAINTENANCE COLLECTION CODES.....	D-1

VARI*LITE
02-3002-0002

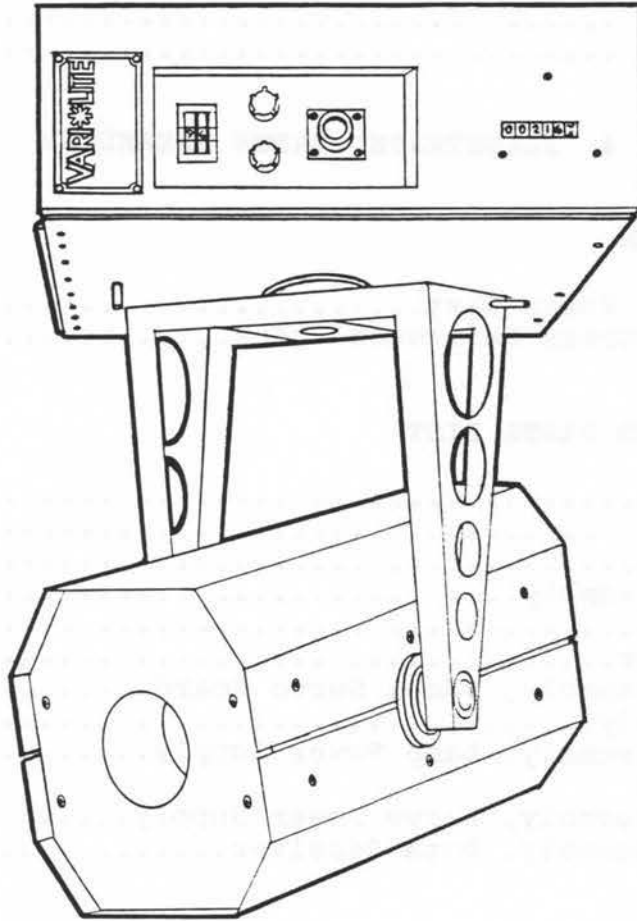

VARI*LITE 1
SPOT LUMINAIRE

CHAPTER 1
INTRODUCTION

Section I. GENERAL INFORMATION

1-1. SCOPE

This manual describes maintenance procedures for the VARI*LITE 1 (VL1) luminaire. The procedures will enable an operator with little or no technical training to isolate and repair most failures encountered with the VL1 luminaire.

Additional technical information is provided in chapter 3. This information will enable the trained electronic technician to troubleshoot and repair circuit card assemblies and lamp power supplies.

1-2. VARIATIONS OF EQUIPMENT COVERED

VARI*LITE 1 luminaires were manufactured in six separate production runs and can be classified as 1st, 2nd, 3rd, 4th, 5th, or 6th generation luminaires according to when they were built. Individual luminaires are identified by serial number. The fifth digit of the serial number indicates to which generation the luminaire belongs.

- FIRST GENERATION: Serial No. 96040001 thru 96040046. Only 17 of these luminaires remain out of the 50 that were originally built. The design of these luminaires is significantly different from the later generations. Maintenance and repair of these luminaires is not covered in this manual.
- SECOND GENERATION: Serial No. 96061001 thru 96061100. One hundred (100) of these luminaires were built. The redesign from model 9604 to model 9606 corrected many of the mechanical deficiencies of the 1st generation luminaires.
- THIRD GENERATION: Serial No. 96062001 thru 96062100. One hundred (100) of these luminaires were built. Design variations differ from 2nd generation primarily due to availability of parts.
- FOURTH GENERATION: Serial No. 96063001 thru 96063150. One hundred fifty (150) of these luminaires were built.

VARI*LITE
02-3002-0002

1-2. VARIATIONS OF EQUIPMENT COVERED (CONT'D)

- FIFTH GENERATION: Serial No. 96064001 thru 96064033. Thirty-three (33) of the original 1st generation luminaires were torn-down and remanufactured to conform to the new design configuration.
- SIXTH GENERATION: Serial No. 96065001 thru 96065380. Three hundred eighty (380) of these luminaires were built. Design variations were made to accomodate various modifications of 2nd thru 5th generation luminaires. This includes a major retro-fit which rearranged the filter/beam wheels in the color-change and beam-size mechanism (refer to para. 2-54).
- INTERCHANGABLE PARTS. Most of the parts and subassemblies in the 2nd thru 6th generation luminaires are interchangeable. Therefore, while the configuration of luminaires within one generation will generally be the same, there are times when a technician on the road will mix and match parts or subassemblies from two or more non-functional luminaires to make one working luminaire that can be used in the show that night.

1-3. MAINTENANCE REPORTING

Report all maintenance actions performed to:

Service Manager
Vari-Lite, Inc.
201 Regal Row
Dallas TX 75247.

1-4. PREPARATION FOR STORAGE OR SHIPMENT

Refer to paragraph 2-68 for instructions for packing the VL1 luminaire into the travel cases.

1-5. SAFETY, CARE AND HANDLING

High voltage is used in this equipment. Death on contact may result if safety precautions are not observed. 115 volts ac is present within the VARI*LITE 1 luminaire. When performing maintenance with covers removed and power on, be very careful to avoid contact with high voltage.

Very high voltage is generated by the Lamp Power Supply (LPS). 165 Vdc is present at the lamp connector terminals when the LPS is on and the lamp is not lit. The LPS also generates start pulses of up to 13,000 volts when lighting the lamp. Be very careful to avoid contact with very high voltage.

1-5. SAFETY, CARE AND HANDLING (CONT'D)

Cooling and heat dissipation within the head assembly is critical to proper operation of the lamp, color change and beam size mechanism, and the dimming mechanism. When performing maintenance with the lamp lit, ensure BOTH head assembly covers are removed or BOTH covers are installed. Operation of the lamp with one cover on and one cover off may result in overheating and cause the thermal fuse to open.

Section II. EQUIPMENT DESCRIPTION

1-6. CHARACTERISTICS

- Motorized pan and tilt functions.
- Motorized intensity control (dimming) function.
- Motorized internal color change mechanism.
- Motorized internal beam size mechanism.
- Programmable remote control of all functions.
- Integrated ac power and control signal cable; only one connection required per lamp.
- Six two- or three-point mounting configurations; no modifications to truss or luminaire required.

1-7. CAPABILITIES AND FEATURES

- Arc light source with daylight color temperature of 5600 degrees Kelvin produces uniform intensity white light of 600 foot candles at 20 feet. Emits little infrared radiation; virtually no heat projected on stage.
- Dimming mechanism goes from full intensity to zero intensity in approximately 0.75 seconds.
- Permanent internal color mechanism produces 92 different colors, from soft pastels to saturated hues, plus white and black. Color change in approximately 0.15 seconds. No gels used.
- Beam size selectable in approximately 0.15 seconds from five hard-edged spot beams, one semi-soft edged spot, and two specialty beam patterns:

Semi-soft spot with 12-foot diameter beam at 20 feet.
Hard-edge spot with beam diameters of two feet up to 10 feet.
Special beam pattern with 16 pin beams in eight-foot diameter.
Special beam pattern with slot beam.

1-7. CAPABILITIES AND FEATURES (CONT'D)

- Pan movement through 350 degrees in 5.5 seconds. Resolution and repeatability of approximately one degree.
- Tilt movement through 270 degrees in 4.5 seconds. Resolution and repeatability of approximately one degree.

1-8. EQUIPMENT DATA

Input Power

Voltage:

Maximum.....	125 Vac
Nominal.....	115 Vac, 50/60 Hz
Minimum.....	105 Vac

Current:

Control circuit (1.5 A fuse).....	less than 1 A
Lamp power circuit (10 A fuse):	
Inrush current.....	8 to 11 A
Lamp lit.....	5 to 6 A
Nominal current draw.....	7.5A @ 120Vac (900W)

Power Calculations (example)

Nominal current +20%.....	9A
x number of luminaires.....	(10)
Total current required.....	90A
/3 phase input power.....	=30A per leg

Dimensions

Overall.....	14"w x 24"l x 24-3/8"h
Upper enclosure.....	14"w x 24"l x 5"h
Head assembly.....	6-7/8"w x 16"l x 8-3/8"h
Storage.....	14"w x 24"l x 20-1/2"h
Weight.....	45 lb.

VARI*LITE
02-3002-0002

1-9. LOCATION AND DESCRIPTION OF MAJOR COMPONENTS

- (A) UPPER ENCLOSURE. Houses lamp power supply, pan mechanism, data receiver and control circuits, dc and servo power supplies.
- (B) YOKE. Mounts head assembly to upper enclosure.
- (C) HEAD ASSEMBLY. Houses lamp, color/beam mechanism, dimming system, tilt mechanism.

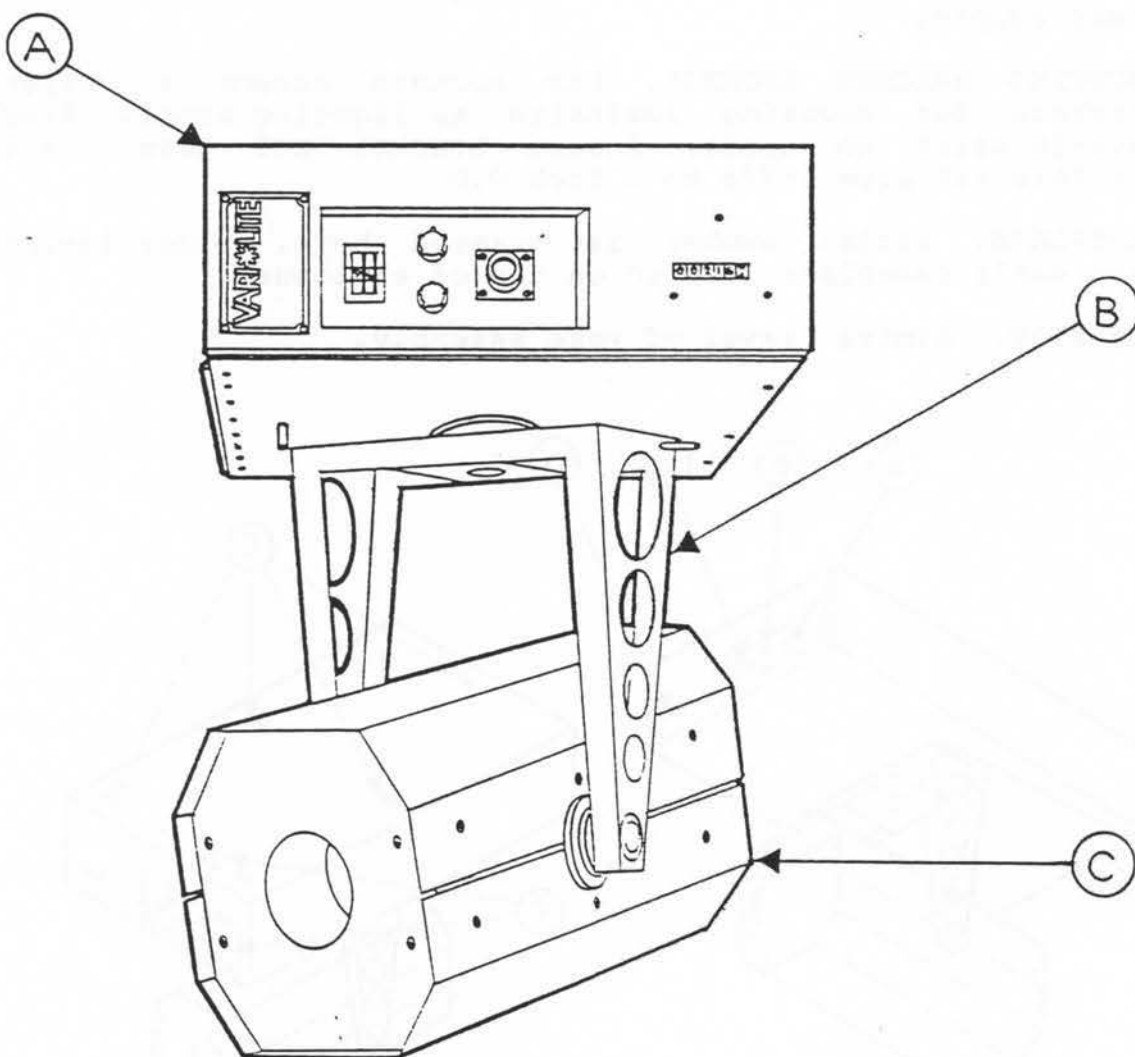

VARI*LITE
02-3002-0002

1-9. LOCATION AND DESCRIPTION OF MAJOR COMPONENTS (CONT'D)

External Components (Upper Enclosure)

- (A) THUMBWHEEL SWITCHES. Set control channel (address) for each luminaire.
- (B) FUSES. Upper: 10 A for lamp power supply, fan, and hour meter; Lower: 1.5 A for dc power supply and control electronics.
- (C) INPUT CONNECTOR. Nine-pin connector for ac power input and control signal input. Connects to Repeater via lamp cable.
- (D) HOUR METER. Records total operating hours of the lamp and lamp power supply.
- (E) MOUNTING BRACKET SOCKETS. Six sockets accept a variety of brackets for mounting luminaire to lighting truss. Brackets lock-in using no tools; insert bracket and give 1/4 turn. Brackets fit pipe 1-7/8 to 2 inch O.D.
- (F) NAMEPLATE. Serial number is stamped here. Older luminaires have small nameplate located on top of enclosure.
- (G) PAN STOP. Limits travel of yoke assembly.

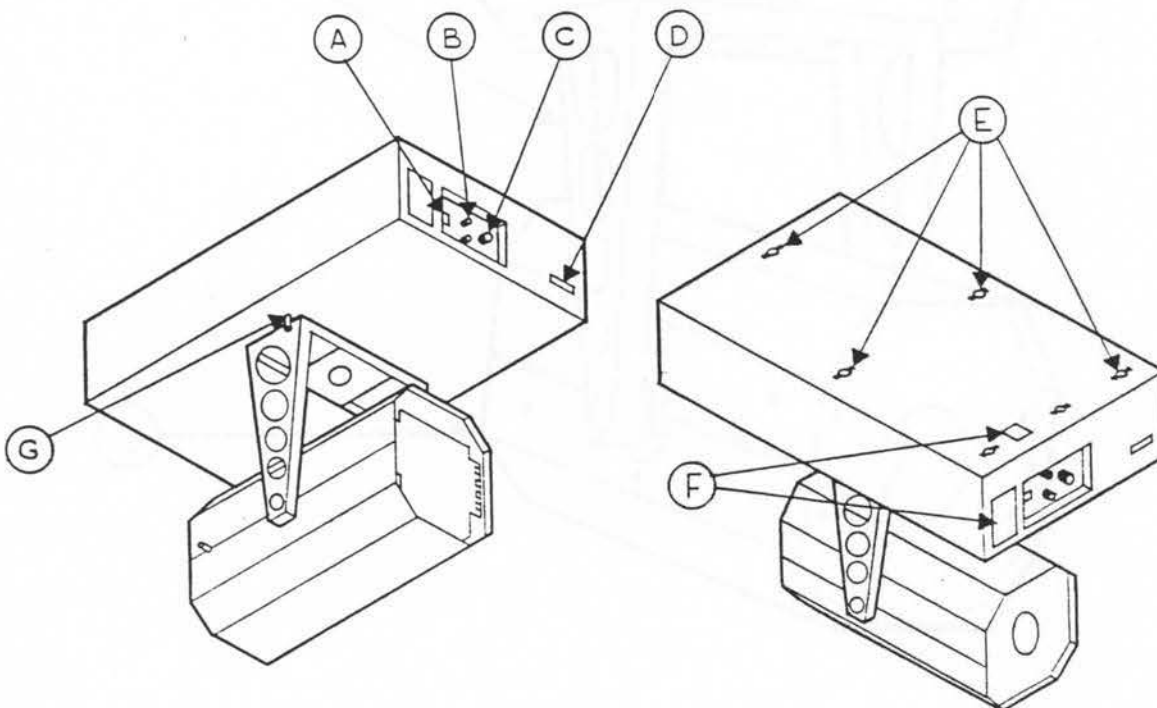

VARI*LITE
02-3002-0002

1-9. LOCATION AND DESCRIPTION OF MAJOR COMPONENTS (CONT'D)

External Components (Head and Yoke Assemblies)

- (A) PAN STOP. Limits travel of yoke assembly.
- (B) WINDOW. Beam output.
- (C) REAR DOOR. Magnetic catch; door opens using no tools. Permits changing lamp in spring-loaded mount also using no tools.
- (D) TILT STOP. Limits travel of head assembly.

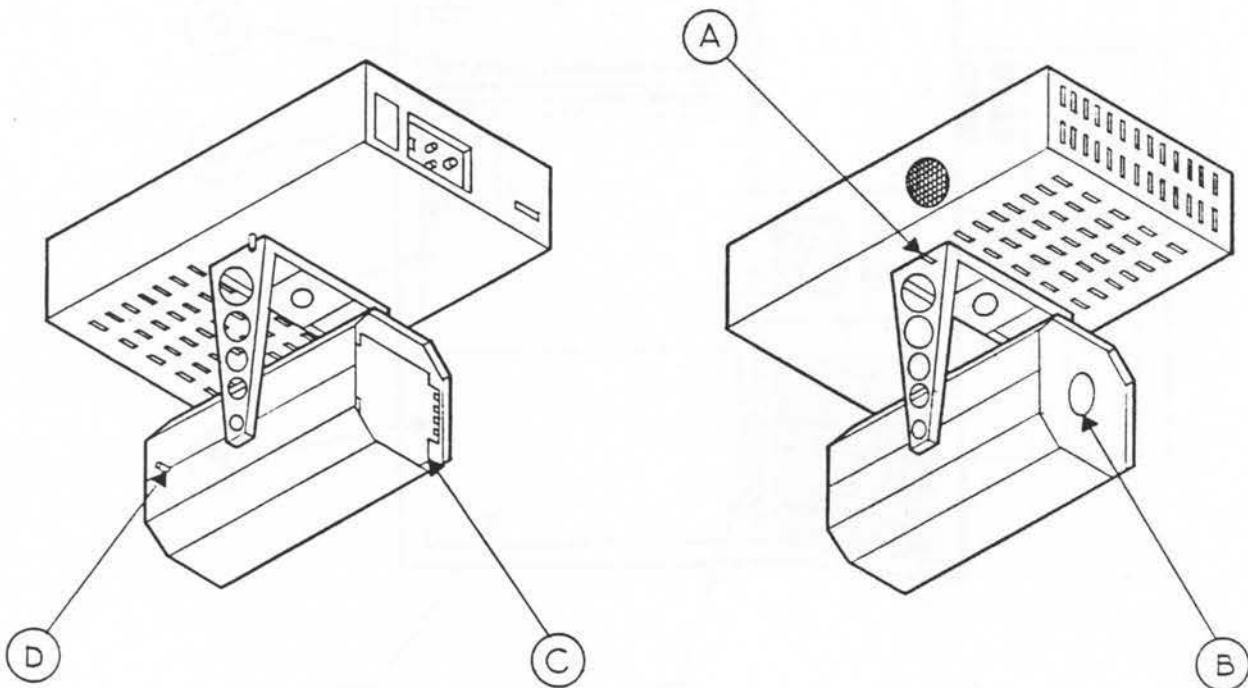

VARI*LITE
02-3002-0002

1-9. LOCATION AND DESCRIPTION OF MAJOR COMPONENTS (CONT'D)

Internal Components (Upper Enclosure)

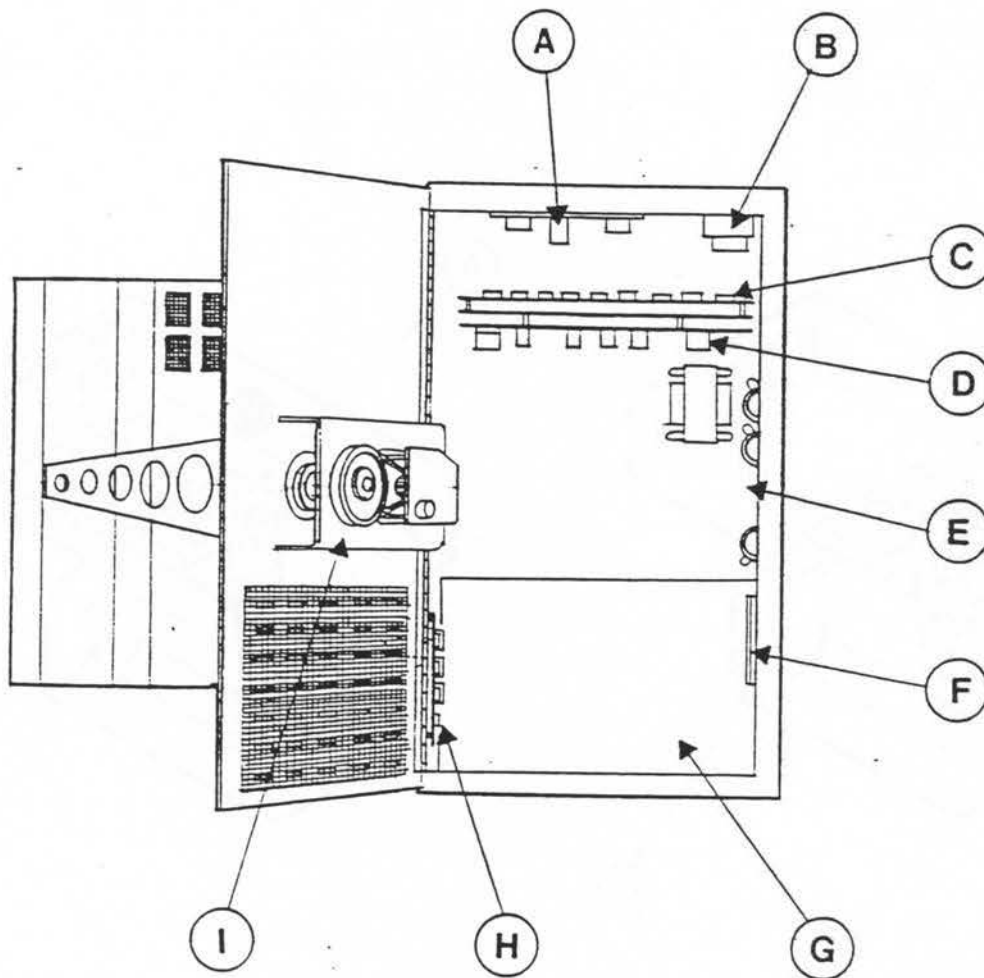

1-9. LOCATION AND DESCRIPTION OF MAJOR COMPONENTS (CONT'D)

Internal Components (Upper Enclosure)

- (A) INPUT PANEL. Contains thumbwheel switches, fuses, and nine-pin input connector.
- (B) HOUR METER. Records total operating hours of lamp and lamp power supply.
- (C) DATA RECEIVER BOARD. Control signal demodulator circuit recovers lamp control data and synchronizing clock signal. Address comparator circuit reads thumbwheel switches and recognizes incoming address control signal. Digital-to-analog converters (DAC) convert digital data to analog control voltage to control servo circuits. Other digital signals control lamp start and douse functions, lamp current control.
- (D) SERVO POWER SUPPLY BOARD. Integrated Circuit (IC) voltage regulators convert the output of the DC Power Supply to the operating voltages required by the servo circuits and logic control circuits. Pan Servo Circuit located on this board for convenience.
- (E) DC POWER SUPPLY. Chassis-mounted components: transformers, bridge rectifiers, electrolytic capacitors; convert 120 V ac input power to dc voltages.
- (F) FAN. Runs on ac power when lamp power supply is on.
- (G) LAMP POWER SUPPLY. Generates 13kV start pulse to light the lamp. Supplies voltage and current to run the lamp in its various operating modes (see above). Three types of switching-mode power supplies are used:

G.E. (General Electric)
EMI 1 (Electronic Measurements Inc. EMRC 350Z-042)
EMI 2 (Electronic Measurements Inc. EMRC 350B-1)
- (H) LAMP POWER SUPPLY CONTROL BOARD. Trimmer potentiometers (trim pots) used to adjust lamp operating current in various operating modes.
- (I) PAN ASSEMBLY. Mechanical assembly rotates Yoke and Head Assembly.

VARI*LITE
02-3002-0002

1-9. LOCATION AND DESCRIPTION OF MAJOR COMPONENTS (CONT'D)

Internal Components (Head Assembly)

- (A) WHEEL SERVO BOARD. Contains six servo circuits to run the tilt assembly, iris assembly, and four wheels in the filter/focal assembly. Three trim pots in each circuit adjust the zero position (ZERO), maximum travel (SPAN), and damping factor (DAMP).
- (B) FILTER/FOCAL ASSEMBLY (FFA). Contains color and beam wheels, drive motors, position feedback pots. Wheels one and three are accessible from this side. Wheel one is closest to the window.
- (C) HEAD FAN. Draws air in through filter and blows across lamp. Deflector mounted between fan and FFA channels air to lamp.

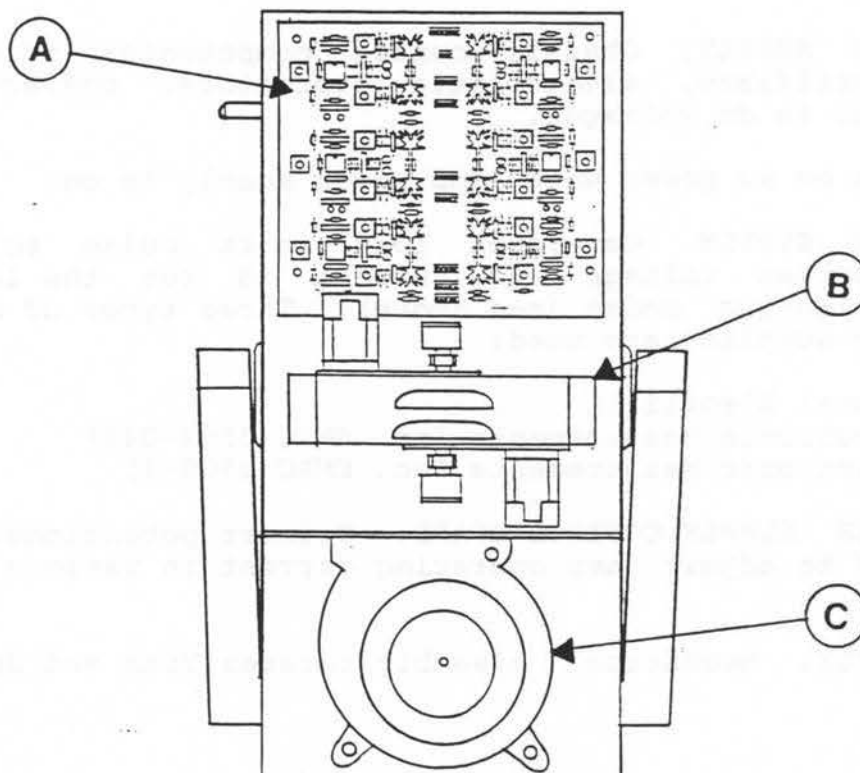

VARI*LITE
02-3002-0002

1-9. LOCATION AND DESCRIPTION OF MAJOR COMPONENTS (CONT'D)

Internal Components (Head Assembly)

- (D) TILT ASSEMBLY. Mechanical assembly tilts head assembly up and down.
- (E) IRIS ASSEMBLY. Lever actuated iris controls intensity of the light beam. Iris closes to dim. Pupil Obstruction Device (POD) blocks the small hole left in the center of the iris when the iris is fully closed.
- (F) LENS. Aspheric optical device converts focused beam from lamp and FFA to linear beam of limited divergence. Located midway between lamp and iris.
- (G) FFA. Wheels two (2) and four (4) are accessible from this side. Wheel four (beam wheel) is closest to lamp. Beam wheel is at the focal point of lamp/lens combination.
- (H) LAMP. GE MARC 350 arc light source. Beam is focused by the lamp's elliptic mirror and converges on a point where the beam wheel is located. Beam then diverges until it reaches the lens.

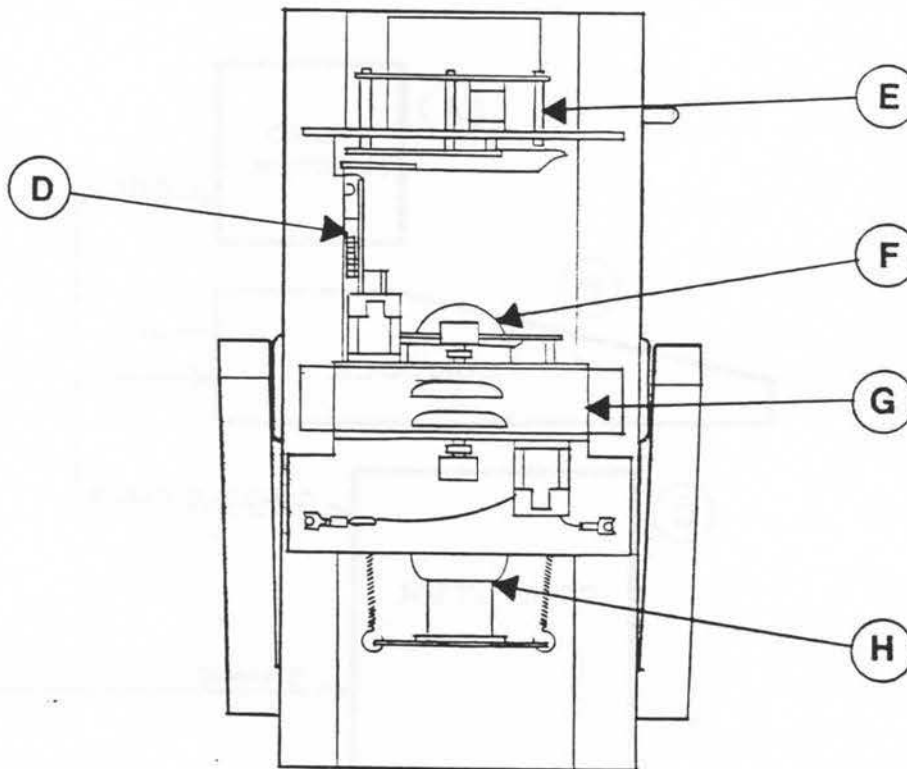

Section III. PRINCIPLES OF OPERATION

1-10. OPERATION IN THE SYSTEM

- (A) VIDEO MONITOR. Shows a programmable display of the VARI*LITE luminaire locations. Indicates which luminaire or group of luminaires is selected for manual control. Indicates which luminaires are active (iris open) in the current cue.
- (B) CONSOLE. Allows the user to remotely control the VARI*LITE luminaires, store cues, and recall cues.
- (C) COMPUTER. Contains control electronics and cue memory storage.
- (D) AC/SIGNAL RACK (ACS RACK). Provides for ac power and control signal distribution between Computer and VARI*LITE 1 luminaires. Connects to three-phase electric service.
- (E) REPEATER. Transmits ac power and control signals from ACS Rack to VARI*LITE luminaires. Connects to ACS Rack through 24-pin trunk cable. Connects to six luminaires through nine-pin lamp cables.
- (F) VARI*LITE 1. Robotic spotlight pans, tilts, dims, changes color and beam size by manual or preprogrammed remote control.

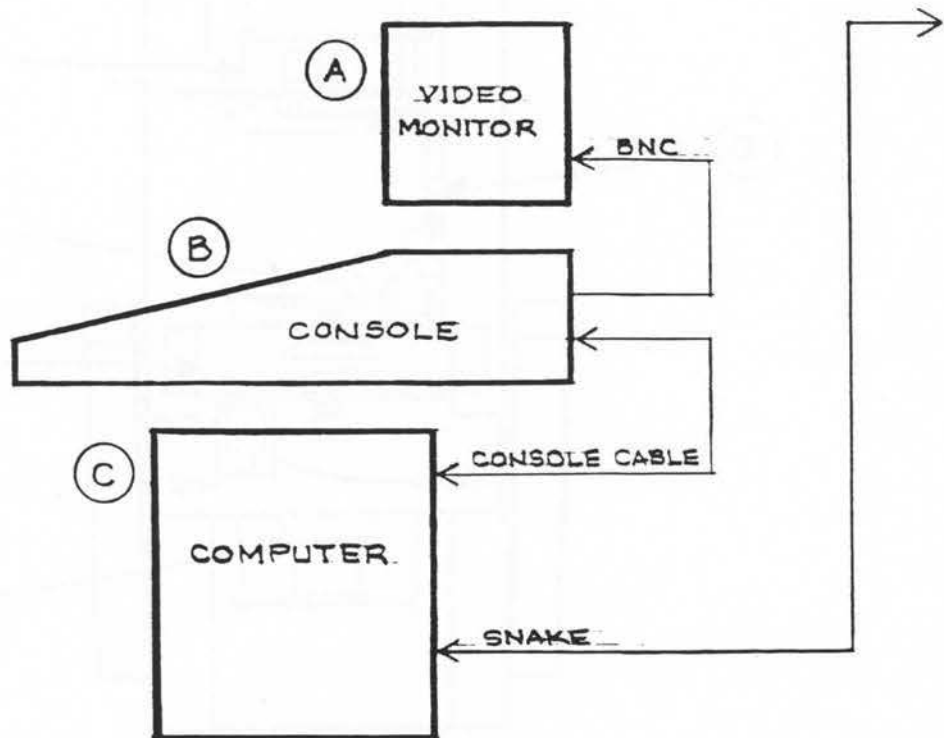

1-10. OPERATION IN THE SYSTEM (CONT'D)

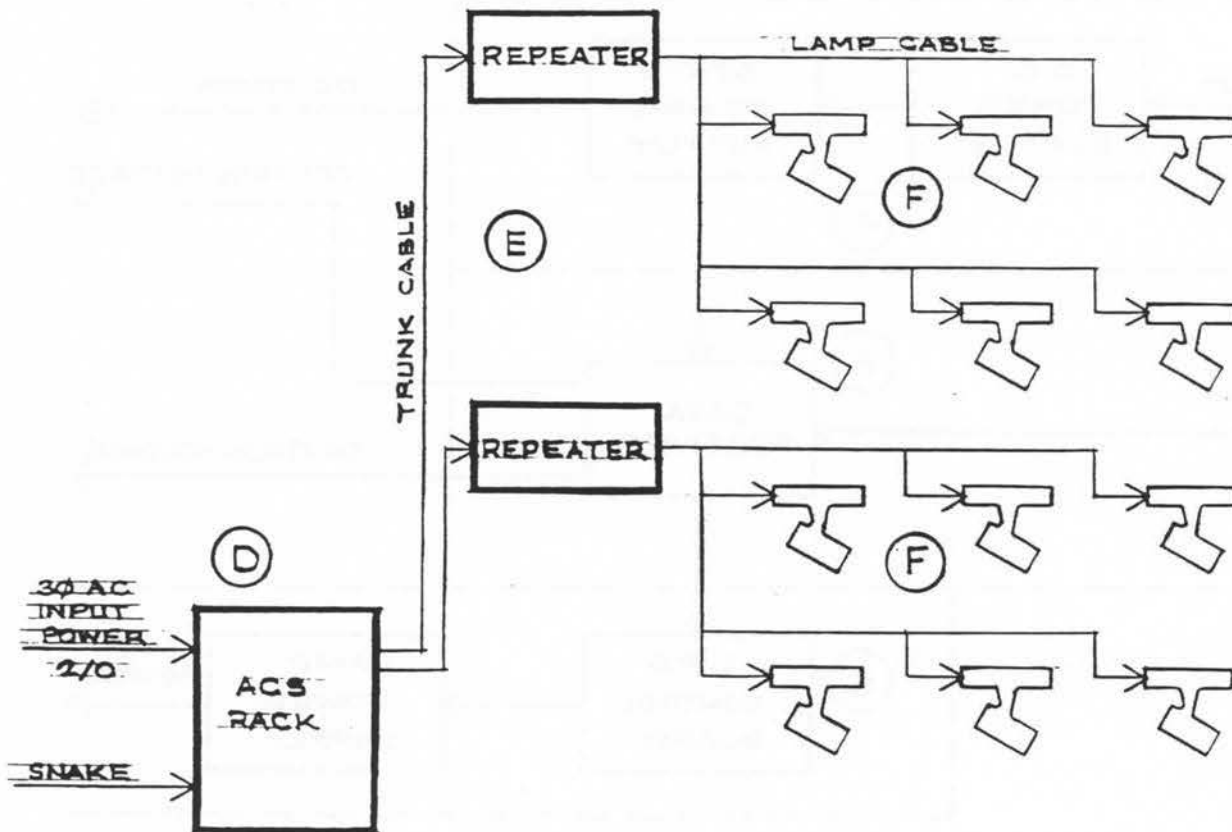

A VARI*LITE 100 Series system may operate with as few as 12 luminaires, one ACS rack, and two repeaters; or as many as 96 luminaires, two ACS racks, and 16 Repeaters. Only one each of the Console, Video Monitor, and Computer is required per system. Different ACS Racks will support 12, 36, or 48 luminaire channels.

The luminaires change color and beam size in discrete steps. Pan and tilt control, and intensity control are continuous. Manual control is used to construct cues which are then stored. The Computer stores up to 255 cues in non-volatile memory. Cue memory can be saved on micro-disk and reloaded at a later date.

Instruments may be operated individually or in groups. Direct Cue Controls permit immediate access to any cue, and allow for rapid stepping between sequential cues. Cross Fade Controls provide for intensity cross fades between luminaires, and for movement cross fades of luminaires from one position to another. Chase Controls allow timed or manual stepping through programmable sequences of cues. Matrix Controls permit conventional intensity control of groups of luminaires for up to eight groups per scene.

1-11. OPERATION OF INTERNAL FUNCTIONS

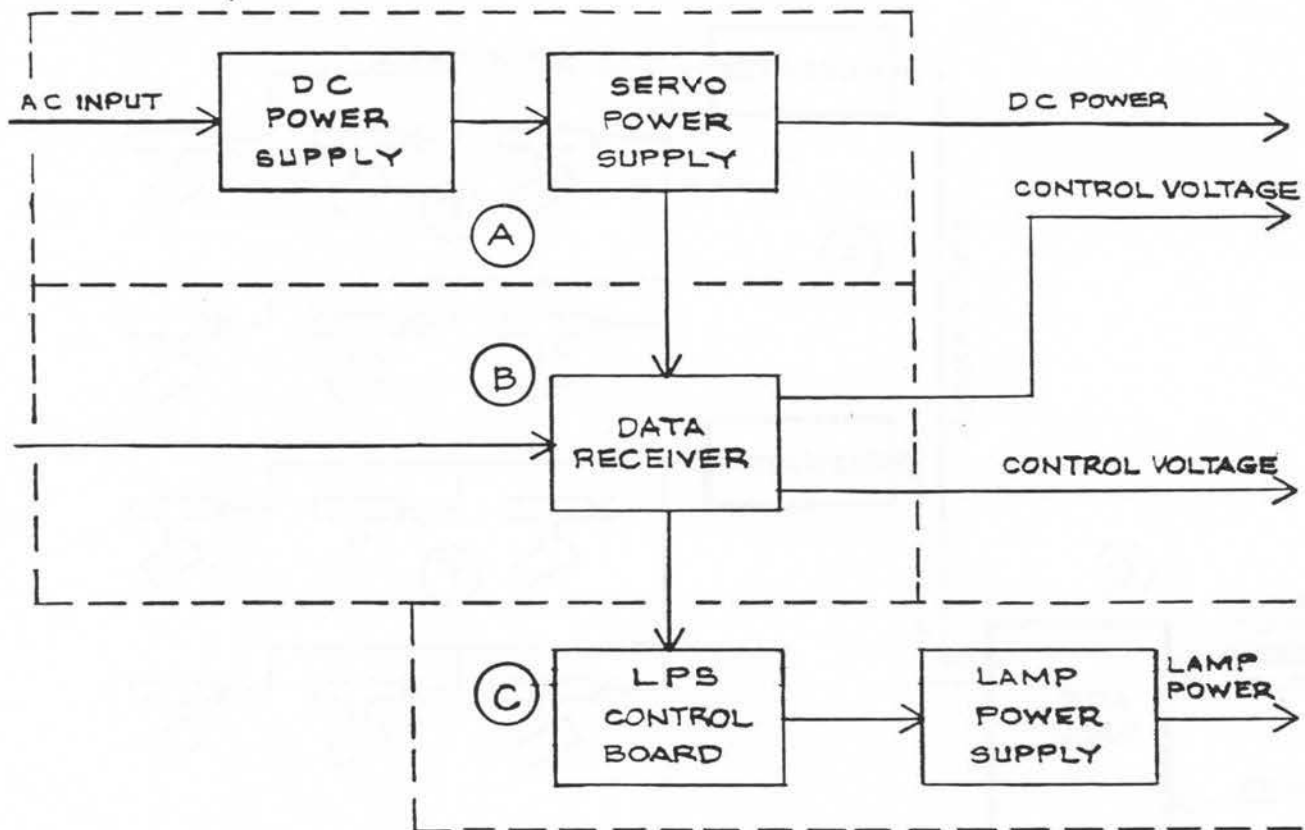

- (A) DC POWER SECTION. Converts ac input power to dc voltages required for all other sections of the luminaire. Includes DC Power Supply and Servo Power Supply Board.
- (B) DATA RECEIVER SECTION. Demodulates control signal input to recover lamp control data. Converts digital data to analog control voltage (dc voltage). Provides control outputs (analog and digital) for all luminaire functions.
- (C) LAMP POWER SECTION. Provides lamp with voltage and current required for starting, running, and standby operation. Includes Lamp, Lamp Power Supply, and Lamp Power Supply Control Board.
- (D) SERVO CIRCUIT SECTION. Compares control voltage from Data Receiver to position feedback voltage from Mechanical Assembly, and generates a motor drive signal to adjust the Mechanical Assembly to the required position. Includes Pan Servo Circuit (located on Servo Power Supply Board) and Wheel Servo Board.

1-11. OPERATION OF INTERNAL FUNCTIONS (CONT'D)

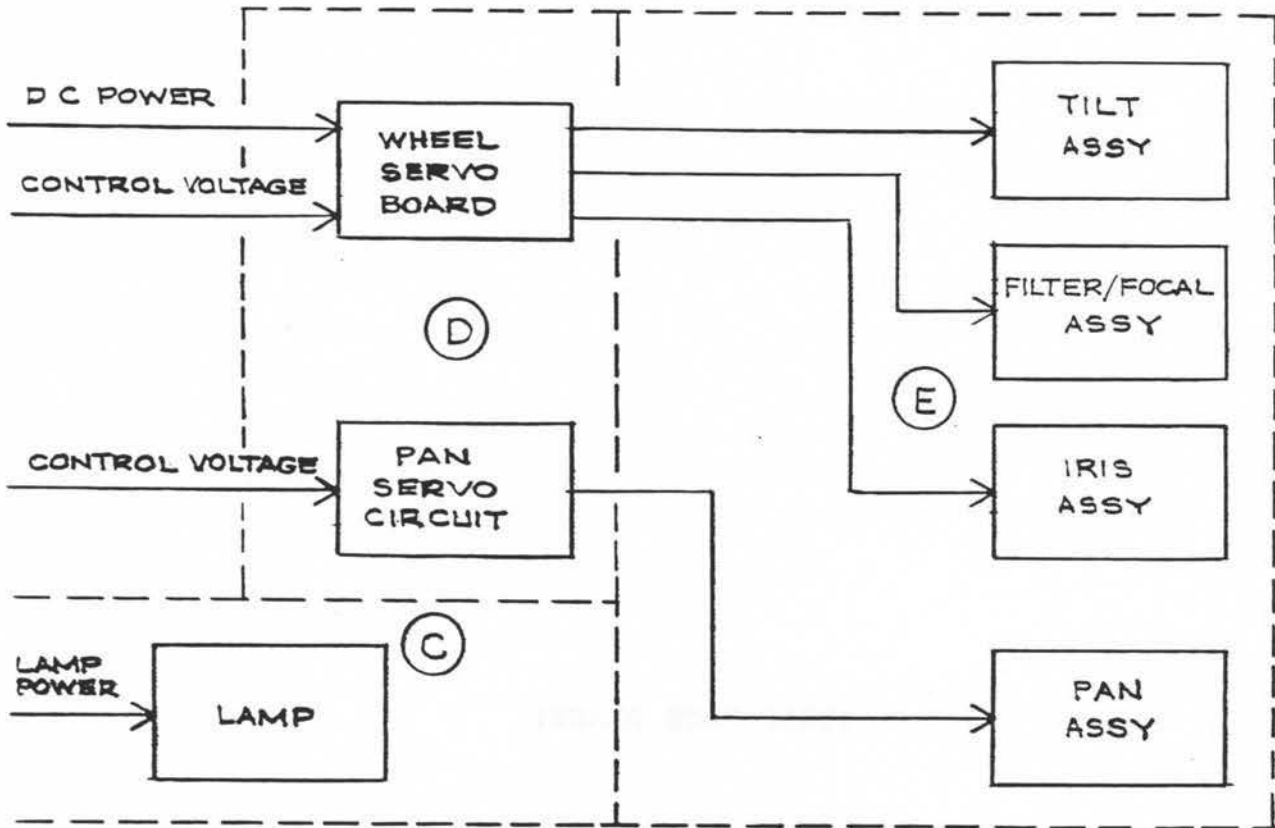

Ⓔ MECHANICAL ASSEMBLY SECTION. Provides movement, intensity control, color change, and beam size change functions for the luminaire. Includes Pan Assembly, Tilt Assembly, Iris Assembly, and Filter/Focal Assembly.

Pan and Tilt Assemblies include dc motors, clutched reduction gears, belt-drive final output, rotating shafts, and position feedback pots.

Iris Assembly includes dc motor, clutch, reduction gears, lever-actuated iris, rotating shafts, and position feedback pot.

Filter/Focal Assembly includes dc motors, four gear-driven filter and beam wheels, rotating shafts, and position feedback pots. All feedback pots are gear driven.

VARI*LITE
02-3002-0002



CHAPTER 2

OPERATOR MAINTENANCE INSTRUCTIONS

Section I. TOOLS AND EQUIPMENT

2-1. COMMON TOOLS AND EQUIPMENT

For a list of tools and test equipment normally supplied with each VARI*LITE 100 Series system, refer to appendix B, Basic Issue Items List.

2-2. SPECIAL TOOLS, TEST AND SUPPORT EQUIPMENT

The following special tools, test and support equipment are required for maintenance of the VARI*LITE 1 (VL1) luminaires:

- MINI-CONTROLLER. Duplicates control signal functions normally provided by control console and control rack. Used to operate luminaire during maintenance, calibration, or troubleshooting.
- DUMMY LOAD/AMMETER. Four ohm resistive load and ammeter test set used to calibrate Lamp Power Supply Control Board. Connects to Lamp Power Supply output at the lamp connector to duplicate load current normally drawn by a lighted lamp.
- OSCILLOSCOPE. Tektronix 2213 (dual-trace), or equivalent.
- MULTIMETER. Fluke 8021B (digital), Fluke 77 (analog/digital), or equivalent.
- TRANSISTOR TESTER. B&K 510 (with probe), or equivalent.

This equipment is normally issued with each system.

VARI*LITE
02-3002-0002

2-2. SPECIAL TOOLS, TEST AND SUPPORT EQUIPMENT (CONT'D)

Mini-Controller

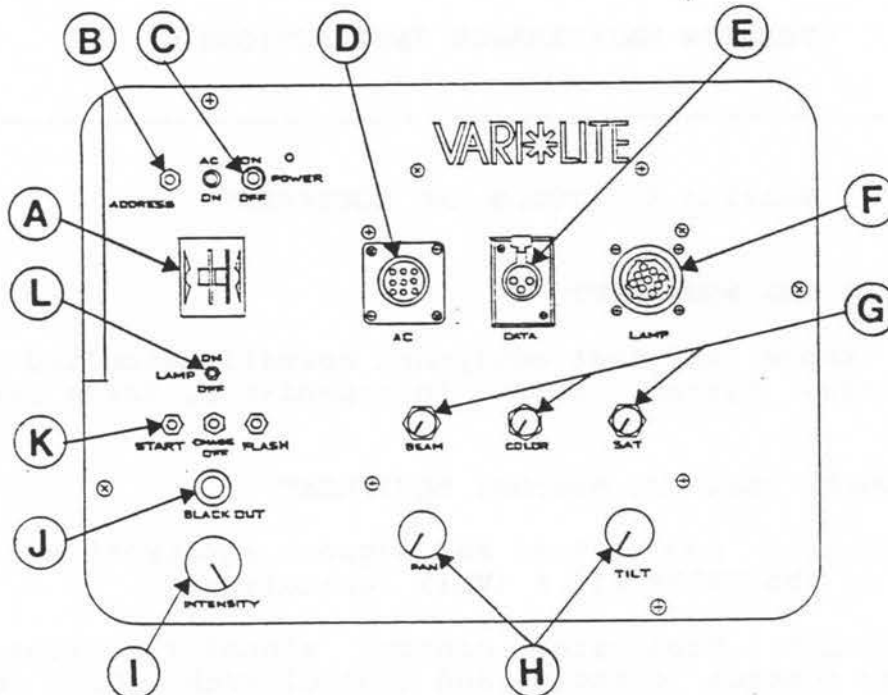

- (A) Thumbwheel switches. Set the control channel number (address) to correspond to the setting on the VARI*LITE luminaire.
- (B) ADDRESS switch. Transmits the thumbwheel address to the luminaire to "get its attention."
- (C) POWER switch. Applies power to the mini controller and to the luminaire connected via the LAMP connector.
- (D) AC POWER connector. Accepts cheater cord with 9-pin connector on one end and standard 3-prong ac power plug on the other.
- (E) DATA input connector. Connects to ACS Rack data input via mic-line (snake).
- (F) LAMP cable connector. Use standard 9-pin lamp cable to connect mini controller to luminaire.
- (G) BEAM, COLOR, SATURATION controls. Used to manipulate FFA wheels.
- (H) PAN, TILT controls. Used to operate pan and tilt functions.
- (I) INTENSITY control. Used to operate iris.
- (J) BLACKOUT button. When pushed in, closes iris and causes luminaire to be non-responsive to other controls.
- (K) START button. Starts lamp if LAMP switch is set to ON.
- (L) LAMP switch. Turns Lamp Power Supply (LPS) in the luminaire ON/OFF.

VARI*LITE
02-3002-0002

2-2. SPECIAL TOOLS, TEST AND SUPPORT EQUIPMENT (CONT'D)

Dummy Load/Ammeter

- A Binding Posts. Used to connect voltmeter across load resistors if ammeter (C) should fail. Current can then be calculated from the voltage across four-ohm load resistors ($I=V/R$).
- B Lamp wires. Connectors provided to mate with 3-pin lamp wire connector or 2-pin lamp socket connector.
- C Ammeter. Indicates lamp current in amperes. Scale is marked at 7.5 and 4.5 amperes for run current and standby current, respectively.

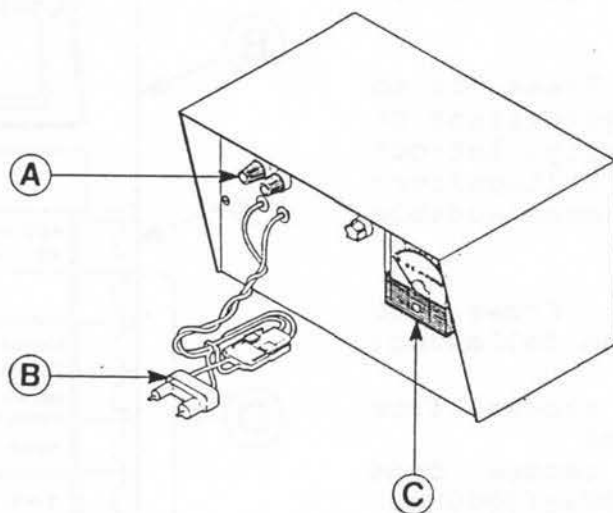

Transistor Tester

The B&K 510 Transistor Tester will identify faulty transistors and silicon-controlled rectifiers (SCR) through in-circuit checks made with the power removed from the circuit. The tester can also be used to test devices which have been removed from the circuit. Refer to paragraph 2-27. Transistor Testing for instructions in the use of the transistor tester.

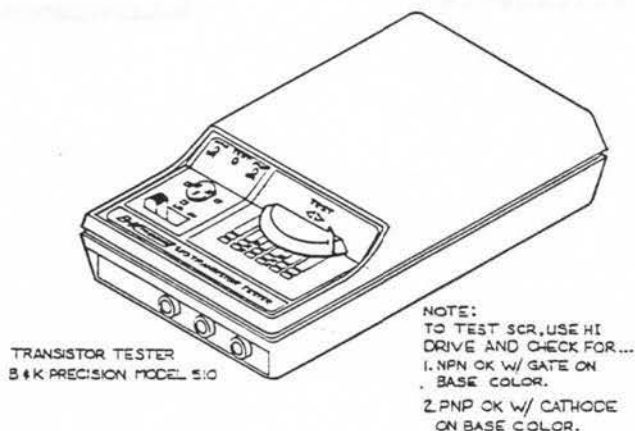

NOTE:
TO TEST SCR, USE HI
DRIVE AND CHECK FOR...
1. NPN OK W/ GATE ON
BASE COLOR.
2. PNP OK W/ CATHODE
ON BASE COLOR.

2-2. SPECIAL TOOLS, TEST AND SUPPORT EQUIPMENT (CONT'D)

Multimeter--Fluke 8021B

The Fluke 8021B is a 6-function multimeter with a 3-1/2 digit display. The functions include ac and dc voltage and current measurement, resistance measurement with audible continuity test, and a diode test function. The meter is powered by one 9 volt battery.

- (A) DISPLAY. 0000 to 1999; over-range indicated by 1 ___ (3 blanks).
- (B) POWER SWITCH. Located on side of case.
- (C) DC/AC SELECT. Press in to select ac voltage/current or audible continuity. Let-out to select dc voltage/current, or to silence audible continuity.
- (D) RANGE SELECT. Press to select one of the following:
 - 4 current ranges from 2mA to 2000mA
 - 5 voltage ranges from 200mV to 750Vac/1000Vdc
 - 6 resistance ranges from 200 to 20M ohms
- (E) FUNCTION SELECT. Press in to select resistance/diode check/continuity. Let-out to select voltage/current.
- (F) INPUT JACKS. Separate inputs for current or voltage/resistance.

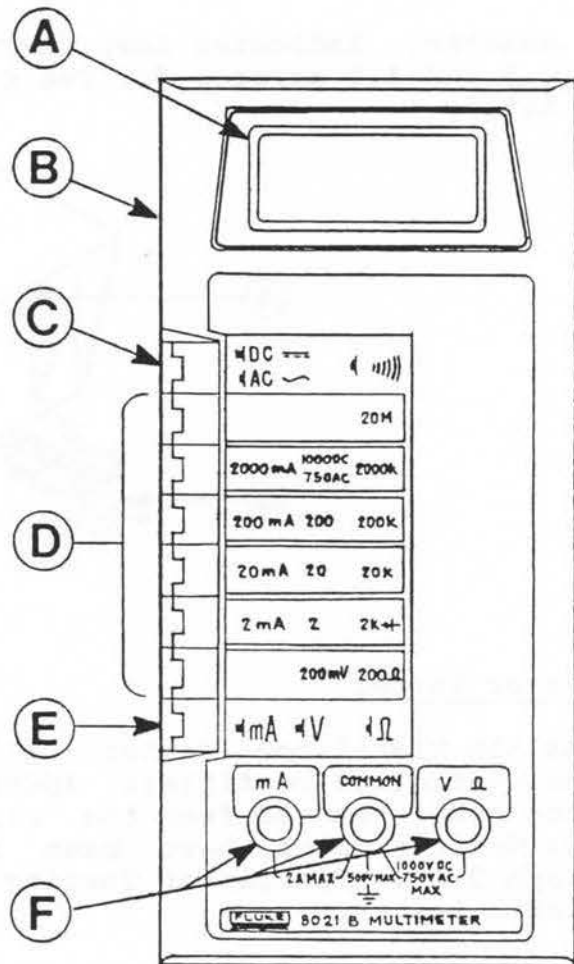

VARI*LITE
02-3002-0002

2-2. SPECIAL TOOLS, TEST AND SUPPORT EQUIPMENT (CONT'D)

Multimeter--Fluke 77

The Fluke 77 is similar to the 8021B, but also provides a 10A current range and a 32 segment bar graph display in addition to the 3-1/2 digit display. The digital display also registers values up to 3200 instead of 1999 on the 8021B. The Fluke 77 also has an autoranging feature which automatically selects the proper range for the parameter being measured.

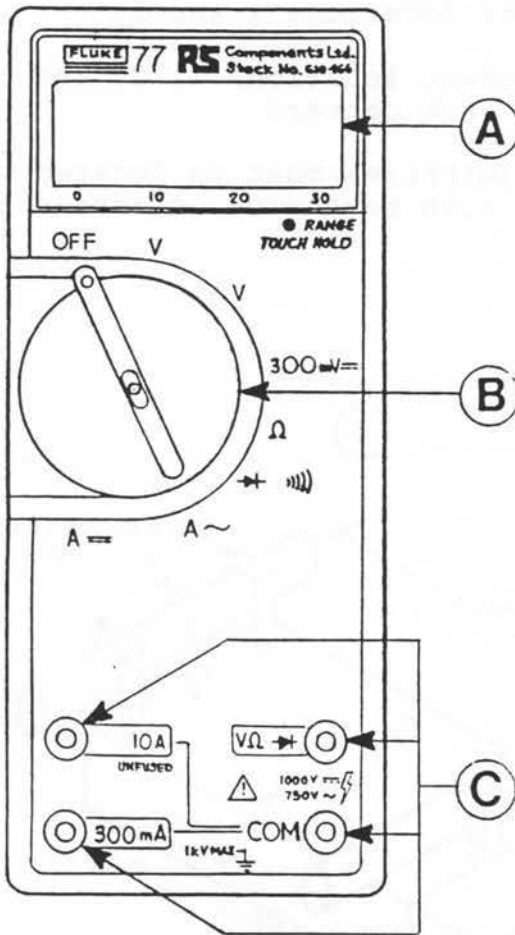

(A) DISPLAY. 0000 to 3200; parameter and range indications provided; over-range indicated by OL.

(B) FUNCTION SELECT. 8-position rotary switch selects function and turns meter on/off. Autoranging feature selects one of the following:

- 2 current ranges; 32 or 320 mA
- 4 voltage ranges from 3.2V to 750Vac/1000Vdc; 300mVdc range manually selected
- 6 resistance ranges from 320 to 32M ohms

(C) INPUT JACKS. Separate inputs for 10A current, 32/320mA current, or voltage/resistance.

2-3. REPAIR PARTS

For a list of spare parts normally issued with each system, refer to appendix B, Basic Issue Items List. A complete list of repair parts appears with illustrations in chapter 4, Illustrated Parts Breakdown. Repair parts not listed in appendix B may be obtained by contacting:

Service Manager
Vari-Lite, Inc.
201 Regal Row
Dallas TX 75247.

Section II. NORMAL OPERATIONS

2-4. MOUNTING REQUIREMENTS

- (A) TWO-POINT MOUNTING. Bracket locations 2 and 3. Brackets mount to truss pipe of 1-7/8 to 2 inches O.D.
- (B) THREE-POINT MOUNTING. Bracket location 1 used with any two locations 4, 5, or 6. Truss pipe must be located on 21-1/4 inch centers.
- (C) ALTERNATE TWO-POINT MOUNTING. Bracket locations 1 and 5.
- (D) ALTERNATE THREE-POINT MOUNTING. Bracket locations 1, 2, and 3. Truss pipe must be located on 10-5/8 inch centers.
- (E) SIDE-TO-SIDE CLEARANCE. Adjacent luminaires must be located on 19 inch centers to avoid interfering with each other's movement.

Typical Installations

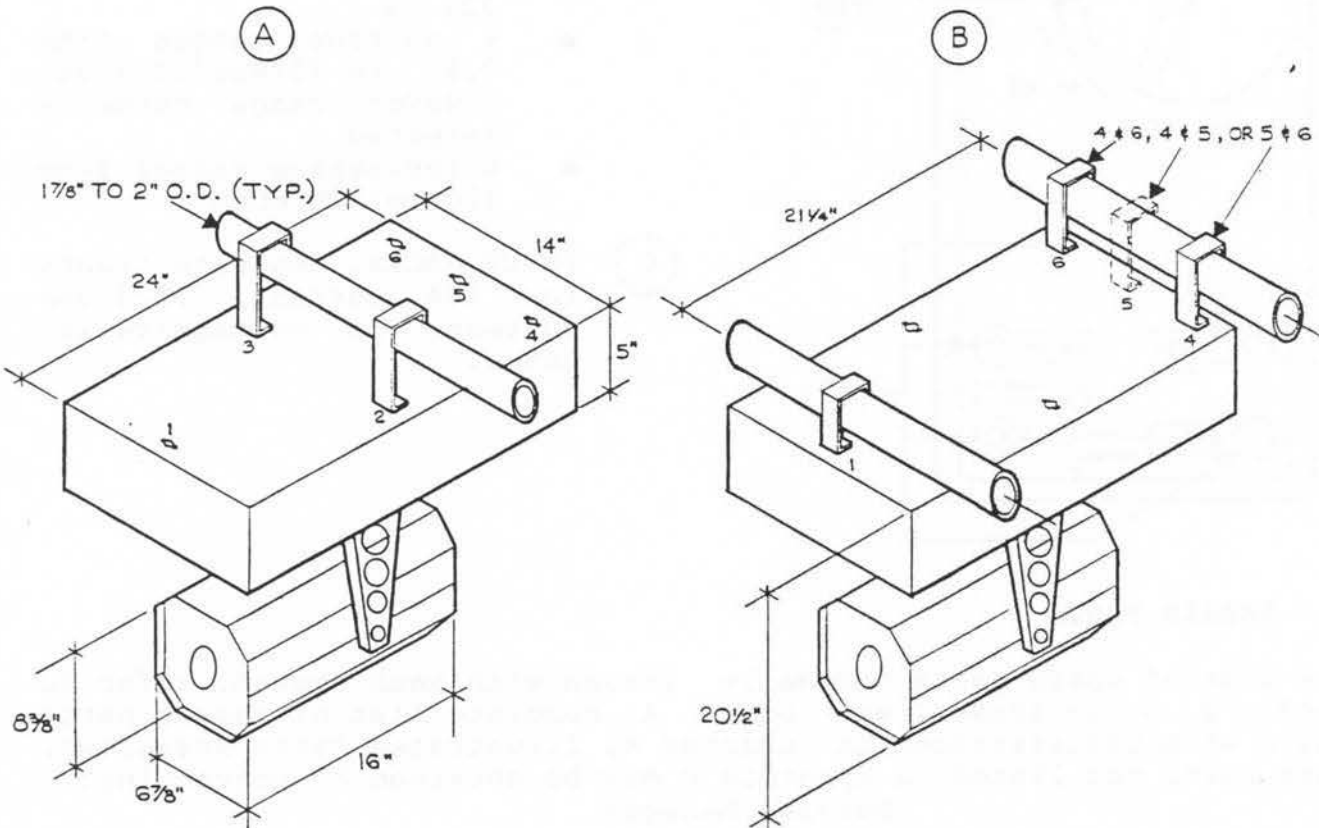

2-4. MOUNTING REQUIREMENTS (CONT'D)

Typical Installations (cont'd)

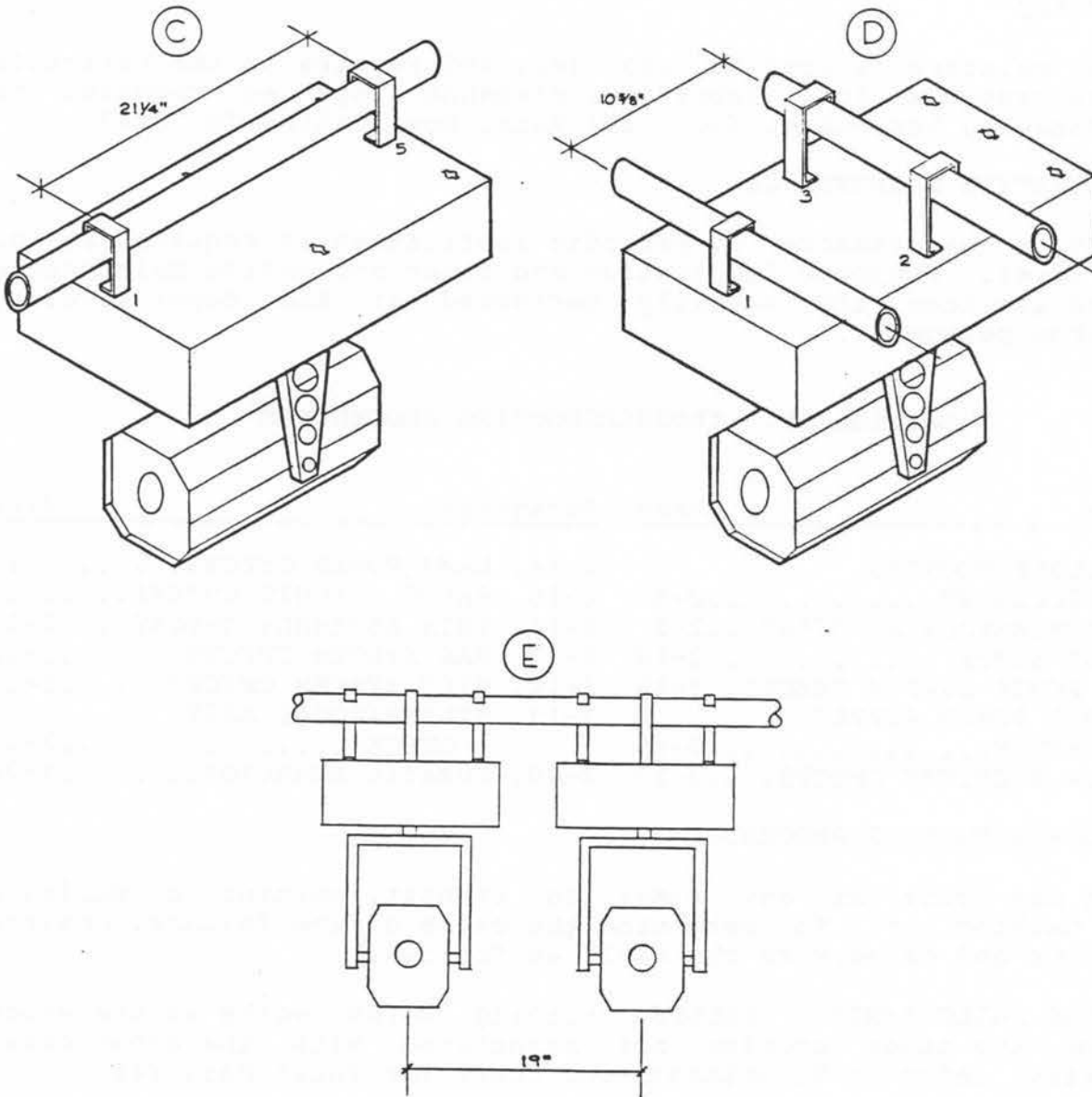

2-5. PRELIMINARY SETTINGS

Set the thumbwheel switches to the control channel address assigned to the luminaire. The addresses will be assigned by the Lighting Designer when the console and display are programmed. Refer to the VARI*LITE Console Operation Manual for more about control channel address assignment. The thumbwheel switches will normally be set at the beginning of a tour or during removal and replacement of a faulty luminaire. If the same luminaire is installed in the same location each time, the thumbwheel setting need not be changed.

Section III. PREVENTIVE MAINTENANCE CHECKS AND SERVICES

2-6. RECORDS

Record all maintenance actions, problems, and repairs on the Vari-Lite weekly maintenance log. Submit maintenance logs as required to Service Manager, Vari-Lite, Inc., 201 Regal Row, Dallas TX 75247.

2-7. PREVENTIVE MAINTENANCE

No preventive maintenance or periodic lubrication is required at the operator level. Periodic lubrication and other preventive maintenance checks and services are normally performed at the depot level by factory shop personnel.

Section IV. TROUBLESHOOTING PROCEDURES

<u>Paragraph</u>	<u>Page</u>	<u>Paragraph</u>	<u>Page</u>
2-8. TROUBLESHOOTING PROCEDURE.....	2-8	2-14. LAMP POWER CHECKS.....	2-19
2-9. TROUBLESHOOTING CHART...	2-9	2-15. SERVO CIRCUIT CHECKS....	2-20
2-10. TEST SETUP	2-14	2-16. IRIS ASSEMBLY CHECKS....	2-21
2-11. DC POWER SUPPLY CHECKS..	2-15	2-17. PAN SYSTEM CHECKS.....	2-22
2-12. SERVO POWER SUPPLY CHECKS.....	2-15	2-18. TILT SYSTEM CHECKS.....	2-22
2-13. DATA RECEIVER CHECKS....	2-17	2-19. FILTER/FOCAL ASSY CHECKS.....	2-23
		2-20. ERRATIC BEHAVIOR.....	2-24

2-8. TROUBLESHOOTING PROCEDURE

A failure can occur at any time; in transit, setting up, during a show, or packing up. To determine the cause of the failure, observe the symptoms and categorize the fault as follows:

- a. TOTAL FAILURE/MISC. FAULTS. Nothing works, works at the wrong time, any other problem not associated with the other categories: refer to Troubleshooting Chart for Total Failures.
- b. LAMP FAULTS. Start/douse problem, faulty lamp: refer to Troubleshooting Chart for Lamp Faults.
- c. INTENSITY FAULTS. Dimming function not working right: refer to Troubleshooting Chart for Intensity Faults.
- d. COLOR/BEAM FAULTS. Color change function not working right, beam size function not working right, color or beam problems: refer to Troubleshooting Chart for Color/Beam Faults.
- e. PAN/TILT FAULTS. Movement function(s) not working right: refer to Troubleshooting Chart for Pan/Tilt Faults.

2-9. TROUBLESHOOTING CHART

Total Failures/Miscellaneous Problems

Item No.	Symptom	Probable Cause	Corrective Action
1.	No response to any commands on any channel.	1. No +5Vdc 2. Bad Receiver Bd 3. Bad input connector 4. Bad lamp cable 5. Thumbwheel Sw 6. Repeater output	Go to para. 2-13
2.	Responds to wrong channel address	1. Thumbwheel Sw 2. Bad Receiver Bd	Go to para. 2-13
3.	Radical failure with smoke and/or fire from unit	1. Exploded capacitor 2. Lamp wire arc 3. Transformer burned-up	Go to para. 2-11 then para. 2-37
4.	Lamp lights but pan tilt, color, beam, and intensity don't work	1. No +/-20Vdc 2. No +/-15Vdc 3. No +/-12Vdc	Go to para. 2-12
5.	Blows 1.5 A fuses	1. Shorted bridge rectifier 2. Loose wire	Go to para.2-11
6.	Upper enclosure fan won't run or runs noisily	1. Bad fan 2. Solid state relay 3. Thermal fuse	Go to para. 2-14 then para. 2-34
7.	Head assembly fan won't run or runs noisily	1. Bad fan 2. Multi-core wire broken	Go to para. 2-33
8.	Erratic stops and starts with low light intensity	1. Low ac line voltage 2. Open bridge rectifier 3. Servo power supply 4. DC power supply 5. Comparator ckt on servo p.s.	Go to para. 2-20
9.	Missing part	1. Part removed to repair another unit	Obtain repair part (para. 2-3)

VARI*LITE
02-3002-0002

2-9. TROUBLESHOOTING CHART (CONT'D)

Lamp Faults

Item No.	Symptom	Probable Cause	Corrective Action
1.	Lamp will not start	1. Bad lamp 2. Bad lamp cable 3. No start pulse 4. Bad lamp power supply 5. Solid state relay 6. No ac power 7. Lamp PS Ctrl Bd 8. Bad Receiver Bd	Go to para. 2-14
2.	Lamp blows up	1. Old lamp 2. Run current too high	Go to para. 2-23 then para. 2-36
3.	Low light output	1. Old lamp 2. Low run current	Go to para. 2-23 then para. 2-36
4.	Light flickers	1. Run current not calibrated 2. Old or defective lamp	Go to para. 2-23 then para. 2-36
5.	Lamp douses by itself	1. Loose ground wire to thermal fuse 2. Faulty lamp power supply control card 3. Run current not calibrated	Go to para. 2-14
6.	Lamp will not douse	1. Faulty data receiver card 2. Solid state relay stuck on	Go to para. 2-14
7.	Lamp discolored	1. Bad lamp	Go to para. 2-36
8.	No start pulse	1. Faulty Lamp PS 2. LPS Ctrl bad 3. Bad receiver bd	Go to para. 2-14 then para. 2-13, step 6.
9.	Lamp starts itself	1. Faulty Lamp PS 2. LPS Ctrl bad 3. Bad receiver bd	Go to para. 2-14 then para. 2-13, steps 4--6.

VARI*LITE
02-3002-0002

2-9. TROUBLESHOOTING CHART (CONT'D)

Lamp Faults (cont'd)

Item No.	Symptom	Probable Cause	Corrective Action
10.	Lamp does not dim when iris is closed	1. Faulty lamp power supply 2. Faulty lamp power supply control card 3. Bad receiver bd	Go to para. 2-13, step 5; then para. 2-40
11.	Blows 10 A fuse	1. Faulty lamp power supply 2. Loose wire	Go to para. 2-14 and check wiring
12.	Blows fuse(s) on lamp power supply	1. Faulty lamp power supply	Go to para. 2-40

Intensity Faults

Item No.	Symptom	Probable Cause	Corrective Action
1.	Iris not functional	1. Bad receiver bd 2. Bad servo ckt 3. Bad mech assy	Go to para. 2-16
2.	Iris sticky	1. Iris leaves need graphite 2. Servo circuit not calibrated 3. Burned leaf in iris assy	Go to para. 2-47 Go to para. 2-24 Go to para. 2-46
3.	Intensity will not go to zero	1. Servo circuit not calibrated 2. Burned POD	Go to para. 2-24 Go to para. 2-48
4.	Intensity will not go to full	1. Servo circuit not calibrated	Go to para. 2-24
5.	Iris overshoots setting and returns	1. Servo circuit not calibrated	Go to para. 2-24
6.	Iris stops short and creeps up to setting	1. Servo circuit not calibrated	Go to para. 2-24

2-9. TROUBLESHOOTING CHART (CONT'D)

Color/Beam Faults

Item No.	Symptom	Probable Cause	Corrective Action
1.	Wheel does not function	1. Bad receiver bd 2. Bad servo ckt 3. Bad mech assy	Go to para. 2-19
2.	Wheel is stuck	1. Gear mesh too tight 2. Debris in gears 3. Wheel seized	Go to para. 2-25, step 6 (adj mesh) Go to para. 2-49 then para. 2-53
3.	Wheel moves slowly	1. Gear mesh too tight 2. Bad servo ckt 3. Bad receiver bd	Go to para. 2-25, step 6 (adj mesh) Go to para. 2-19
4.	Beam shape is not round	1. FFA wheels not calibrated 2. Filament crooked	Go to para. 2-25 Go to para. 2-36
5.	Wheel jitters	1. Bad feedback pot 2. Gear mesh not adjusted right 3. Worn gear teeth	Go to para. 2-19; or para. 2-25, step 6 (adj mesh) or para. 2-53
6.	Wheel overshoots setting and returns	1. Servo circuit not calibrated	Go to para. 2-25 check DAMP
7.	Wheel overshoots and continues	1. Servo circuit not calibrated 2. Bad fdbk pot	Go to para. 2-25 or para. 2-51
8.	Wheel stops short and creeps up to setting	1. Servo circuit not calibrated	Go to para. 2-25 check DAMP
9.	Colors are wrong, wheel turns to wrong position	1. Bad receiver bd 2. Bad servo ckt 3. Bad mech assy 4. Filters in wrong places	Go to para. 2-13 or para. 2-15 or para. 2-19 or para. 2-54
10.	Filter gone bad	1. Color shift 2. Peeling 3. Cracked, gone	Go to para. 2-54 replace filter

2-9. TROUBLESHOOTING CHART (CONT'D)

Color/Beam Faults (cont'd)

Item No.	Symptom	Probable Cause	Corrective Action
11.	Beam size/pattern is wrong	1. Aperture or gobo fallen out 2. Wheel turned to wrong position	Go to para. 2-54 replace gobo/aptr Go to para. 2-25
12.	Slot pattern does not line-up right	1. Slot gobo turned	Go to para. 2-54 fix gobo

Pan/Tilt Faults

Item No.	Symptom	Probable Cause	Corrective Action
1.	Pan not functional	1. Bad receiver bd 2. Bad servo ckt 3. Bad mech assy	Go to para. 2-17
2.	Tilt not functional	1. Bad receiver bd 2. Bad servo ckt 3. Bad mech assy	Go to para. 2-18
3.	Yoke hits pan stop	1. Servo circuit not calibrated	Go to para. 2-25
4.	Head hits tilt stop	2. Servo circuit not calibrated	Go to para. 2-25
5.	Overshoots pan/tilt setting and returns	1. Servo circuit not calibrated	Go to para. 2-25 check DAMP
6.	Head/yoke stops short and creeps up to pan/tilt setting	1. Servo circuit not calibrated	Go to para. 2-25 check DAMP
7.	Stiff, jerky movement; motors fight back when moving by hand	1. Clutch too tight	Go to para. 2-60
8.	Slow, slipping movement; may not tilt up all the way	1. Clutch too loose	Go to para. 2-60
9.	Undershoots setting	1. Servo circuit not calibrated	Go to para. 2-25

VARI*LITE
02-3002-0002

2-10. TEST SETUP

Set up the faulty luminaire and test equipment as follows:

1. Using cheater cord, connect the mini-controller to 115Vac.
2. Using nine-pin lamp cable, connect the VARI*LITE luminaire to the mini-controller.
3. Set thumbwheel switches on the mini-controller to match the address set on the luminaire.
4. Set mini-controller POWER switch to ON. Press the ADDRESS button on the mini-controller. The luminaire is now ready to receive commands from the mini-controller.

NOTE

If thumbwheel switch settings are changed during the procedure, press the ADDRESS switch again to transmit the new address.

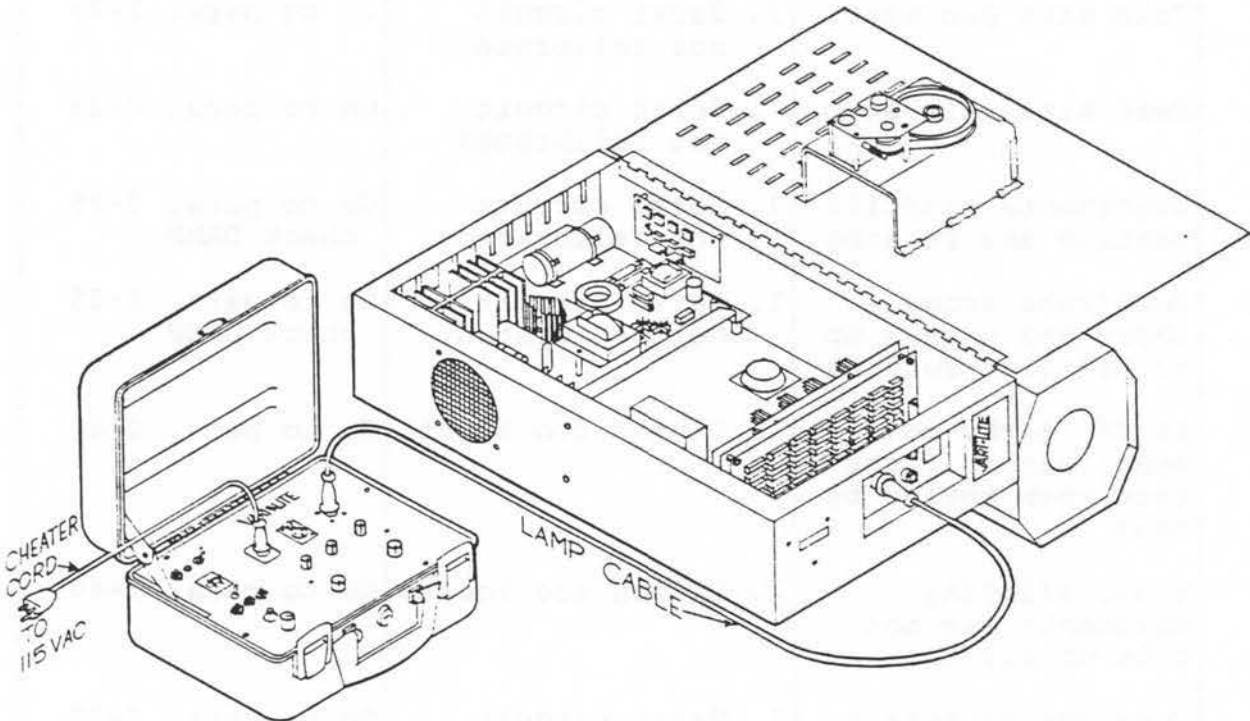

2-11. DC POWER SUPPLY CHECKS

Test

The dc power supply may be considered functional if the output voltages to the servo power supply are correct.

1. Using No.2 Phillips screwdriver, remove five screws from the upper enclosure access panel and open the enclosure, as required.
2. Using multimeter, verify +25Vdc across capacitor C1.
3. Using multimeter, verify -25Vdc across capacitor C2.
4. Using multimeter, verify +8Vdc across capacitor C3.
5. Inspect the wiring between filter capacitors C1--C3 and the servo power supply board. Ensure connections are clean and tight, wires are not nicked or broken, and insulation is undamaged. Look for evidence of burned or melted insulation.

Fault Isolation

If the voltage on the capacitor is low, the capacitor is leaky and must be replaced. The most common failures are broken or loose wires, and failed bridge rectifiers. You can check the ac voltage at the unmarked rectifier terminals to verify proper operation of the transformer and ac input fuse.

To check a rectifier, remove power from the VARI*LITE luminaire, then unplug the wires from the rectifier terminals. Set the multimeter to the diode position and measure between adjacent terminals, alternating the test leads. One direction should read open circuit. The other direction should read about 600 ohms.

2-12. SERVO POWER SUPPLY CHECKS

Test

The servo power supply may be considered functional if the voltage outputs to the data receiver and to the yoke are correct. The Pan servo circuit will be checked in paragraph 2-17.

1. Using No.2 Phillips screwdriver, remove five screws from the upper enclosure access panel and open the enclosure, as required.
2. Using multimeter, verify +20Vdc on the case of the 2N6227 transistor.

2-12. SERVO POWER SUPPLY CHECKS (CONT'D)

Test (cont'd)

3. Using multimeter, verify -20Vdc on the case of the 2N5759 transistor.
4. Using multimeter, verify output voltages at connectors as follows:

Connector	Voltage	Gnd Ref	Remarks
P1-1	-20Vdc	P1-2	Motor power to yoke
P1-3	+20Vdc	"	" " " "
P2-1	-15Vdc	P2-3	Servo power to yoke
P2-2	-12Vdc	"	" " " "
P2-4	+12Vdc	"	" " " "
P2-5	+15Vdc	"	" " " "
P3-1	-15Vdc	P3-3	Receiver power
P3-4	+12Vdc	"	" "
P3-5	+15Vdc	"	" "
P5-1	+5Vdc	P5-3	Receiver power
P5-2	+5Vdc	"	" "

Fault Isolation -- 20 Volt Regulator Circuits

If you measure 25 volts on the case of the large transistor, check for a faulty Q6 (A or B) regulator. Also check for burned resistors on either side of Q6A and Q6B. You may also have a shorted Q1 or Q2, although this is very rare.

To check the LM317/337 regulators, measure the dc voltage between the output pin (center pin) and the adjustment pin (left-hand pin). If the voltage measures 1.25 +/- 0.02 Vdc, the regulator is working properly.

If you measure 0 volts on the case of the large transistor, first verify +/-25Vdc input from the dc power supply. Then check for shorted 1.0 uf capacitor. Also check for a faulty Q6 (A or B) regulator. You may also have an open collector on Q1 or Q2, although this is rare. If the +/-25Vdc input is not there, refer to paragraph 2-12. DC Power Supply Checks.

If you measure 0 volts at P1-1 and P1-3, the servo motor relay is open. Check the 12 volt outputs at P2 and the 5 volt output at P5. If any of these outputs are bad, the protection circuit will open the servo motor relay thereby disconnecting the 20 volt outputs from the servo motor circuits. If these outputs are good and the relay is still open, check the voltage-comparator protection circuit (U2 and associated components).

2-12. SERVO POWER SUPPLY CHECKS (CONT'D)

Fault Isolation -- 15/(12) Volt Regulator Circuits

If the positive regulator circuit has failed, replace Q5A/(Q4A). Also check for burned resistors beside the regulator. If the negative regulator has failed, check for shorted 1.0 uf capacitor (if you measure 0 volts) or else replace Q5B/(Q4B). Also check for burned resistors beside the regulator.

Fault Isolation -- 5 Volt Regulator Circuit

If you measure 8 volts at P5, replace Q3. If you measure 0 volts at P5, first verify +8Vdc input from the dc power supply. Then check for shorted 1.0 uf capacitors or else replace Q3. If the +8Vdc input is not there, refer to paragraph 2-12. DC Power Supply Checks.

2-13. DATA RECEIVER CHECKS

The data receiver board may be considered functional if the servo control voltages respond over the required ranges and the lamp control signals respond as required. First, verify the input power is good, then check the output signals.

Input Power Checks

1. Using No.2 Phillips screwdriver, remove five screws from the upper enclosure access panel and open the enclosure, as required.
2. Using multimeter, verify input voltages at connectors as follows:

Connector	Voltage	Gnd Ref	Remarks
P5-1	+12Vdc	P5-5	Reference voltage for DAC-08
P5-2	-15Vdc	"	Power to DAC-08 and 1458 opamps
P5-3	+15Vdc	"	" " " " " "
P6-1	+5Vdc	P6-3	Power to all other digital devices
P6-2	+5Vdc	"	" " " " " "

If the input voltages are not correct, refer to paragraph 2-12. Servo Power Supply Checks.

2-13. DATA RECEIVER CHECKS (CONT'D)

Output Signal Checks -- Servo Control

3. Using multimeter, verify servo control voltages vary through the ranges specified while operating the corresponding control.

Connector	Voltage Range	Gnd Ref	Control
P5-2	-8 to +8 Vdc	P5-1	PAN
P7-3	-6 to +6 Vdc	"	TILT
P7-1	0 to +12 Vdc	"	INTENSITY
P7-2	0 to +12 Vdc	"	BEAM
P7-4	0 to +12 Vdc	"	COLOR/SATURATION
P7-5	0 to +12 Vdc	"	" "
P7-6	0 to +12 Vdc	"	" "

If there is no response from one or more of the servo control voltage outputs, check or replace components in the signal path: 1458 opamp, DAC-08, 4076 latch, or 6801 PROM (for Color outputs).

If there is no response from any of the servo control voltage outputs, check the thumbwheel switches (refer to step 7). If thumbwheels are good, replace 2630 opto-coupler (U1). If all else fails, replace the data receiver board.

Output Signal Checks -- Lamp Control

4. Check LMPON (Lamp On) signal. Using multimeter, verify 0Vdc at P4-2. Set LAMP switch to ON and verify P4-2 goes to +5Vdc.
5. Check LSTBY (Lamp Standby) signal. Rotate INTENSITY control fully clockwise. Ensure BLACKOUT button is up. Using multimeter, verify P4-5 is at 0Vdc. Press BLACKOUT button and verify P4-5 goes to +5Vdc.
6. Check LMPST (Lamp Start) signal. Using multimeter, verify P4-3 is at +5Vdc. Press START button and verify P4-3 goes to 0Vdc. Lamp should start at this time.

If the LMPON or LMPST signals are bad, replace U27, the 4572 IC. If that doesn't work, replace the receiver board.

If the LSTBY signal is bad, replace the receiver board.

2-13. DATA RECEIVER CHECKS (CONT'D)

Test Thumbwheels

- Set thumbwheel switches to 00. Using multimeter, verify 0Vdc at pins 1 thru 4 of connectors P2 and P3. Step through all 10 settings on each thumbwheel switch and check the voltage levels at connectors P2 and P3 for each setting.

DECIMAL (SETTING)	BINARY				NOTES
	PINS: 8	4	2	1	
0	0	0	0	0	0 = 0.0 to +0.5 Vdc 1 = +2.4 to +5.0 Vdc P2 = ones digit P3 = tens digit
1	0	0	0	1	
2	0	0	1	0	
3	0	0	1	1	
4	0	1	0	0	
5	0	1	0	1	
6	0	1	1	0	
7	0	1	1	1	
8	1	0	0	0	
9	1	0	0	1	

- If thumbwheel switches are bad, check for faulty wiring or replace switches.

2-14. LAMP POWER CHECKS

To test the lamp power system, perform lamp power supply calibration (para. 2-23). Check for faulty lamp. Verify lamp lights.

If lamp power supply is totally dead, proceed as follows:

- Check the 10 A fuse located on the input connector panel of the upper enclosure. Replace blown fuse as required.
- Check the thermal fuse (micro-temp) located on the heat shield behind the FFA. Using multimeter, verify continuity thru the fuse. If the meter reads open circuit, replace the blown thermal fuse (para. 2-39).
- Check the LMPON signal from the receiver board. Using multimeter, verify +5Vdc at receiver board P4-2 when LAMP switch is set to ON (para. 2-14. step 8). If conditions are not as specified, replace receiver board (para. 2-31).
- Check solid state relay. Using multimeter, verify +3.5 to +5.0 Vdc across terminals 3 and 4. Verify 115Vac at terminal 2 (from 10 A fuse). If either measurement is not as specified, check for faulty wiring. Verify 115Vac at terminal 1. If this measurement is not as specified, replace the solid state relay (para 2-38).

2-14. LAMP POWER CHECKS (CONT'D)

5. If the solid state relay is functional, verify 115Vac across terminal AC1 and AC2 on the lamp power supply. If the ac power is not there, check for faulty wiring or loose connections.
6. If the lamp power supply is getting 115Vac and its output is totally dead, check for loose quick-disconnect tabs on the lamp power supply printed circuit board. Verify ac power input wires are connected to the correct terminals. Resolder the quick-disconnects if loose.
7. Visually inspect wiring between the circuit board and the various LPS chassis-mounted components and assemblies. Check for broken wiring, especially where ty-wraps may put excessive strain on solder connections. Repair wiring as required.
8. If all else fails, replace the lamp power supply and lamp power supply control board (para. 2-40).

2-15. SERVO CIRCUIT CHECKS

The most common problem with the servo circuit will cause the motor to run continuously in one direction. One FFA wheel may spin around and around; the head may tilt up, hit the tilt stop and keep running; the yoke may pan around, hit the pan stop and keep running; or the iris may open or close all the way and keep running. If this happens, proceed as follows:

1. Determine which servo circuit has malfunctioned. If the pan circuit is the problem, open the upper enclosure to gain access to the pan servo circuit on the servo power supply board. If one of the other servo circuits is the problem, remove the head assembly covers to gain access to the wheel servo board.
2. Adjust the SPAN trim pot to try to stop the wheel rotation. If this does not work, proceed with step 3.
3. Remove the dual opamp IC from the faulty circuit. This is the 8-pin TL072 device mounted in an IC socket.
4. If the motor stops running, the problem is in the IC. Replace with a new TL072.
5. If the motor continues to run, the problem is a faulty transistor. Remove power from the luminaire and check the transistors in the faulty servo circuit (para. 2-27). Reinstall the original IC.

A less common problem with the servo circuit is faulty trim pots. If you have a problem with the Zero, Span, or Damp adjustment in one of the servo circuits and the trim pot seems to have no effect on the circuit operation or the calibration just won't work right, replace the faulty trim pot.

2-15. SERVO CIRCUIT CHECKS (CONT'D)

If you run the test at the motor terminals and get no motor drive voltage out of the servo circuit, check the transistors in the faulty circuit (para. 2-27), replace the TL072 IC opamp.

2-16. IRIS ASSEMBLY CHECKS

If the iris assembly is not functional, first verify the receiver board is functional (para. 2-13). If the INTENSITY output (P7-1) varies between 0 and +12Vdc, proceed as follows to determine whether the fault is in the servo circuit or the iris assembly:

1. Remove the head assembly covers to gain access to the iris assembly.
2. Using multimeter, measure the dc voltage at the iris motor positive terminal (red wire). Put the meter's common lead on an unpainted part of the head assembly chassis. You should read 0.0 +/- 0.5 Vdc.

NOTE

When the iris assembly operates correctly, the voltage at the motor terminals will rise briefly and return to zero as the iris moves to the new position.

3. Turn the INTENSITY control on the mini-controller all the way in each direction. You should read some value between 5 and 20 volts for a moment. The voltage will read positive when you turn the control one direction and negative when you turn it the other direction.
4. If you get no voltage at all, the servo circuit or the wiring is faulty. Try the same test at the 5-pin IDC connector on the wheel servo board. Measure between P8-1 and P8-3 (red and black wires). If you still get no voltage, the servo circuit is faulty. Refer to paragraph 2-15. Servo Circuit Checks.
5. If the test at the motor terminals shows a dc voltage as specified, but the motor does not run, check for faulty ground wire (the black wire), faulty brushes (para. 2-35), or replace the motor (para. 2-42).

2-17. PAN ASSEMBLY CHECKS

If the pan assembly is not functional, first verify the receiver board is functional (para. 2-13). If the PAN output (P5-2) varies between -8 and +8Vdc, proceed as follows to determine whether the fault is in the servo circuit or the pan assembly:

1. Open the upper enclosure to gain access to the pan assembly.
2. Using multimeter, measure the dc voltage at the pan motor terminals. Use some clip leads to connect the meter terminals to the motor terminals, and lower the upper enclosure cover.
3. Turn the PAN control on the mini-controller all the way in each direction. You should read some value between 15 and 20 volts until the yoke pans to the new position. The voltage will read positive when you turn the control one direction and negative when you turn it the other direction.
4. If you get no voltage at all, the servo circuit or the wiring is faulty. Try the same test at the 5-pin IDC connector on the servo power supply board. Measure between P4-1 and P4-3 (red and black wires). If you still get no voltage, the servo circuit is faulty. Refer to paragraph 2-15. Servo Circuit Checks.
5. If the test at the motor terminals shows a dc voltage as specified, but the motor does not run, check for faulty brushes (para. 2-35), or replace the motor (para. 2-59).

2-18. TILT ASSEMBLY CHECKS

If the tilt assembly is not functional, first verify the receiver board is functional (para. 2-13). If the TILT output (P7-3) varies between -6 and +6Vdc, proceed as follows to determine whether the fault is in the servo circuit or the tilt assembly:

1. Remove the head assembly covers to gain access to the tilt assembly.
2. Unplug the +/-20 Vdc connector from P1 on the wheel servo board.
3. Measure the dc voltage at the tilt assembly feedback pot (on the green wire). Tilt the head up and down, and verify the dc voltage varies smoothly between -5.5 and +5.5 Vdc. If the pot does not respond properly, it may be faulty and should be replaced (para. 2-61).
4. Plug-in the +/-20 Vdc connector to wheel servo board P1.
5. Using multimeter, measure the dc voltage at wheel servo board connector P7-1 and P7-3 (red and black wires). Since the tilt motor is not accessible when installed, this test must be performed at the servo circuit output. You should read 0.0 +/- 0.5 Vdc.

2-18. TILT ASSEMBLY CHECKS (CONT'D)

6. Turn the TILT control on the mini-controller a small amount in each direction. You should read some value between 15 and 20 volts until the head tilts to the new position. This will be tricky since the connector you are measuring at will move as the head tilts. The voltage will read positive when you turn the control one direction and negative when you turn it the other direction.
7. If you get no voltage at all, the servo circuit is faulty. Refer to paragraph 2-15. Servo Circuit Checks.
8. If the test at the servo circuit connector shows a dc voltage as specified, but the motor does not run, check for faulty wiring, faulty brushes (para. 2-35), or replace the motor (para. 2-59).

2-19. FILTER/FOCAL ASSEMBLY (FFA) CHECKS

If one of the wheels is not functional, first verify the receiver board is functional (para. 2-13). If the BEAM and WHEEL outputs (P7-2,-4,-5,-6) vary between 0 and +12Vdc, proceed as follows to determine whether the fault is in the servo circuit or the FFA:

1. Remove the head assembly covers to gain access to the FFA.
2. Unplug the motor/pot connector from the servo circuit and plug it into another wheel servo circuit.
3. Turn the BEAM, COLOR, or SATURATION controls and check if the wheel is now functional. If the wheel turns, the fault is in the servo circuit. If the wheel is still not functional, plug the connectors back in their proper places and check the motor and feedback pot.
4. Loosen the mounting screws from the motor mount and feedback pot mount. Back the motor and pot away from the wheel.
5. Try to move the wheel by hand. If it moves, chances are the gear mesh was too tight. Refer to paragraph 2-25. FFA Calibration to adjust gear mesh. If it doesn't turn freely, the shaft is stuck. Refer to paragraph 2-53. Filter/Beam Wheel Disassembly and replace shaft/wheel as required.
6. Turn the BEAM, COLOR, or SATURATION control on the mini-controller some amount and see if the motor runs. If not, check for faulty brushes (para.2-35) or replace the motor (para. 2-50).
7. Measure the dc voltage at the FFA wheel feedback pot (on the green wire). Turn the wheel by hand, and verify the dc voltage varies smoothly between 0.0 and +12 Vdc. If the pot does not respond properly, it may be faulty and should be replaced (para. 2-51).

2-20. ERRATIC BEHAVIOR

Erratic stops and starts with low light intensity are usually caused by low ac line voltage at the end of a long cable run. When the line voltage is very low, operation of the luminaire's motors may cause the line voltage to drop further. When this happens, the comparator circuit on the servo power supply board opens the servo enable relay (see NOTE below). The relay connects +/-20 Vdc to the servo circuit and when opened, shuts off the motors. The line voltage then rises and, after a couple of seconds, the process repeats.

To troubleshoot this situation proceed as follows:

1. Check the ac line voltage. Unplug the lamp cable from the luminaire and measure at the 9-pin cable connector. Verify voltage is greater than 95 Vac.
2. Check the dc power supply (para. 2-12) for open bridge rectifier, shorted capacitor, or burned transformer.
3. Check the servo power supply (para. 2-13) for faulty 20 volt regulator circuit. Especially check Q1 and Q2 for open collector. Verify the .22 ohm/5 watt resistors have not increased in resistance. Check for faulty Q6A/B.
4. Check the servo power supply for faulty 12 volt regulator circuits. The positive and negative regulators must track within 0.7 volts of each other or the comparator circuit will open the servo enable relay.

NOTE

The LM339 comparator chip located on the servo power supply board has been deemed unnecessary. As of 6/30/86, all LM339 chips should be removed, thereby disabling the comparator circuit. This will allow the luminaire to operate at a much lower line voltage without problems.

5. If no other faults are detected replace U2, the LM339 comparator IC, on the servo power supply board.

Section V. CALIBRATION AND CHECKOUT PROCEDURES

<u>Paragraph</u>	<u>Page</u>	<u>Paragraph</u>	<u>Page</u>
2-21. SERVO CIRCUIT CALIBRATION.....	2-25	2-24. IRIS CALIBRATION	2-27
2-22. PAN/TILT CALIBRATION....	2-25	2-25. FFA CALIBRATION.....	2-28
2-23. LAMP POWER SUPPLY CALIBRATION.....	2-26	2-26. OPERATIONAL CHECKOUT....	2-29

2-21. SERVO CIRCUIT CALIBRATION

The servo circuits must be calibrated when any repairs are made to the circuit or the associated mechanical assembly. The calibration procedure consists of two parts: (1) zero the position feedback pot and adjust gear mesh; (2) adjust the trim pots on the circuit board. Both parts must be performed following disassembly/reassembly or repair of the mechanical assembly.

Trim pot adjustment by itself will fix some problems. However, if the feedback pot is not properly zeroed, the trim pot adjustment will not calibrate the system correctly.

Time permitting, all seven servo circuits: Pan, Tilt, Iris, Beam, and Color wheels 1 thru 3; should be calibrated whenever the luminaire is down for maintenance on any servo circuit. For complete calibration of the entire luminaire, perform lamp power supply calibration (para. 2-23) following pan/tilt calibration.

2-22. PAN/TILT CALIBRATION

The pan and tilt circuits should be calibrated first, since those circuits go to zero position immediately when the luminaire is powered-up. Once the luminaire is accessed by the mini-controller ADDRESS button, the zero position is difficult or impossible to find.

1. Connect the mini-controller to ac power. Connect the luminaire to the mini-controller (para. 2-10, steps 1 and 2). Do not press the ADDRESS button.
2. Check the pan and tilt zero positions. The yoke should be square to the upper enclosure and the corner aligned with the pan stop. The head assembly should be straight up and down; check for equal spacing on either side of the yoke.
3. If the zero position is way out, set trimpot to mid-position, loosen the screws clamping the feedback pot to the bracket and turn the body of the pot to correct the zero position. Adjust the zero trim pot(s) as required to fine-tune the zero position(s).
4. Set the thumbwheel switches on the luminaire and mini-controller so they match and press the ADDRESS button.

2-22. PAN/TILT CALIBRATION (CONT'D)

5. Turn the PAN and TILT controls all the way in one direction. See that the pan stops come to within about 1/8 inch of each other. See that the yoke splits the tilt bracket mounting screw head in half.
6. Adjust the SPAN trim pot(s) to increase or decrease the amount of pan or tilt travel.
7. Turn the PAN and TILT controls all the way in the other direction. When the head and yoke assemblies come to rest, see that the pan stops come to within about 1/8 inch of each other, and the yoke splits the other screw head in half.
8. If there is too much pan travel, decrease the SPAN until the pan stops no longer touch. If there is too little pan travel, or if the tilt travel is off, adjust the ZERO trim pot to correct half the distance then adjust the SPAN trim pot to correct the rest of the distance.
9. Turn the PAN and TILT controls all the way in the other direction and check the positions again. Repeat the ZERO and SPAN adjustments until pan and tilt travel are properly adjusted.
10. Change the PAN and TILT settings and observe the yoke and head movement. Check that the assembly moves smoothly to the new position and stops right at it. If the assembly stops and then makes a small correction either forward or back, the circuit is improperly damped.
11. Adjust the DAMP trim pot(s) as required and repeat step 8 until the circuit is properly damped.

2-23. LAMP POWER SUPPLY CALIBRATION

The lamp power supply must be calibrated when any repairs are made to the lamp power supply or to the lamp power supply control card, or when these units are replaced. The calibration procedure may also be used to check out the lamp power supply and lamp power cables during troubleshooting.

To calibrate the lamp power supply, proceed as follows:

1. Refer to paragraph 2-10 and set up luminaire and test equipment, as required.
2. Using No.2 Phillips screwdriver, remove five screws from the upper enclosure access panel and open the enclosure, as required.
3. Ensure LAMP switch on mini-controller is set to OFF. Disconnect the three-pin connector on the lamp power supply output cable. Check for burned or corroded 3-pin connector. Connect the output cable to the dummy load/ammeter.

VARI*LITE
02-3002-0002

2-23. LAMP POWER SUPPLY CALIBRATION (CONT'D)

4. Check lamp wires leading to yoke. Ensure lamp wires are not hung on anything. Verify yoke pans without interference from lamp wires.
5. Set LAMP switch on mini-controller to ON. Ensure BLACKOUT button is up, and the luminaire iris is open. Operate INTENSITY control as required to open the iris.
6. Verify test set ammeter indicates 7.5 ± 0.1 amperes. Adjust RUN trim pot on lamp power supply control card to calibrate run current.
7. Press BLACKOUT button or operate INTENSITY control to close the luminaire iris.
8. Verify ammeter indicates 4.5 ± 0.1 amperes. Adjust STANDBY trim pot on lamp power supply control card to calibrate standby current.
9. Calibration is now complete. Set LAMP switch to OFF.

If the lamp power supply is totally dead, no output current at all, refer to paragraph 2-14. Lamp Power Checks.

If some output current is present, but run current and/or standby current cannot be calibrated, replace lamp power supply and lamp power supply control board (para. 2-40).

2-24. IRIS CALIBRATION

To prepare for iris calibration, first calibrate the pan and tilt circuits (para. 2-22), or refer to paragraph 2-10. Test Setup, as required.

1. To zero the feedback pot, remove the iris assembly, leaving the IDC connector hooked-up to the wheel servo board.
2. Set the ZERO trim pot to its mid-position.
3. Set the mini-controller INTENSITY control fully CCW (counter-clockwise).
4. Loosen the nut on the feedback pot and turn the body of the pot until the iris is closed.
5. Tighten the nut and reinstall the iris assembly.
6. Adjust the ZERO trim pot until the iris just closes around the POD. Do not close the iris too tight or it will stick.

2-24. IRIS CALIBRATION (CONT'D)

7. Set the mini-controller INTENSITY control fully CW (clockwise).
8. Adjust the SPAN trim pot until the iris leaves are showing about 1/8 inch all around. Do not open the iris too far or the leaves may stick in the diaphragm.

Remove the head assembly front bulkhead and clean the window. Turn the head assembly up and sprinkle a little graphite on the iris. Work the iris arm back and forth to open and close the iris a few times. When the iris is well lubricated, blow any loose graphite off the lens and the backside of the wheel servo board. Reinstall the head assembly front bulkhead.

2-25. FFA CALIBRATION

To prepare for FFA calibration, first calibrate the pan, tilt, and iris assemblies (para. 2-22 and 2-24) or refer to paragraph 2-10. Test Setup, as required. Remove the lamp so you can visually inspect the wheel positions through the rear door.

1. Set the mini-controller BEAM, COLOR, and SATURATION controls fully CCW.
2. Set the ZERO trim pots for wheels 1 thru 4 so the arrow points toward the heat sinks. Set the SPAN trim pots to about a 7 o'clock position.
3. Starting with wheel 4, the beam wheel, loosen the nut on the feedback pot and rotate the body of the pot until the zero position (largest opening) is centered in the round bulkhead opening. Tighten the nut.
4. Check the feedback pot gear to ensure the gear is parallel to the wheel. Loosen the nut and readjust pot until gear is straight.
5. Check gear mesh. A little play in the gears (rocking motion about 1/2 gear tooth distance) is best. Do not get it too tight (wheel will stick when hot) or too loose (gears will chatter). With the nut loose, move the pot in or out to adjust gear mesh. Tighten nut.
6. Check motor gear mesh. A little play in the gears is best, same as for feedback pot gear. Loosen the top mounting screw and tilt the motor in or out to adjust gear mesh. Tighten top mounting screw and check gear mesh again. Repeat adjustment as required.

2-25. FFA CALIBRATION (CONT'D)

7. Adjust the ZERO trim pot to fine-tune the zero position.
8. Repeat steps 3 thru 7 for wheels 1, 2, and 3.
9. Set the mini-controller BEAM control fully CW.

NOTE

If any wheel goes into a spin, turn the SPAN trim pot for that circuit CCW until the spin stops.

10. Adjust the SPAN trim pot in the wheel 4 circuit until the 16-pin gobo is lined-up with the zero positions on the color wheels. Set the BEAM control back to fully CCW.

NOTE

If you unplug two color wheels from the wheel servo board, you can set the SPAN adjustment on one wheel at a time without interference from the other two wheels.

11. Turn the SATURATION control up a notch, until the color wheels move to the first setting.
12. If any of the color wheels are not lined-up just right, move them around by hand until you determine which one is out. Then adjust the SPAN trim pot for that wheel servo circuit until the wheel is lined-up just right.
13. Turn the SATURATION control up another notch and check the color wheels again. Repeat step 12 as required.
14. Repeat steps 12 and 13 until you are satisfied that all the wheels are properly calibrated.
15. Reinstall the lamp and perform the operational checkout (para. 2-26).

2-26. OPERATIONAL CHECKOUT

Following calibration of the mechanical assemblies/servo circuits and lamp power supply, start the lamp and check operation of the luminaire as follows:

1. Set the LAMP switch on the mini-controller to ON.
2. Ensure the BLACKOUT button is up and the iris is open. Address the luminaire (press ADDRESS button) and set INTENSITY control fully CW as required.

VARI*LITE
02-3002-0002

2-26. OPERATIONAL CHECKOUT (CONT'D)

3. Press the START button until the lamp is started. The lamp will flash a few times as the start pulse is applied. Once the lamp is lit, release the START button.

NOTE

A modification to the mini-controller permits stepping through the color wheels one filter at a time.

4. Direct the beam on the ceiling or wall and step through the various beam sizes and gobos. Operate the COLOR and SATURATION controls to observe all 21 filters. Check the following:
 - Beam sizes are round; no 'footballs;'
 - Colors look good; no cracked, peeling or shifted filters;
 - Wheels turn freely; no sticking, spinning or chattering;
5. Operate the INTENSITY control and verify iris works smoothly. Verify dimming action looks good. Check for light leaks when fully dimmed.
6. Let the luminaire run until the iris and FFA wheels heat-up. Check color, beam, and intensity functions again to ensure the mechanical assemblies do not stick when hot.

Section VI. MAINTENANCE PROCEDURES

Paragraph	Page	Paragraph	Page
2-27. TRANSISTOR TESTING.....	2-31	2-34. UPE FAN REPLACEMENT.....	2-40
2-28. SOLDERING.....	2-33	2-35. MOTOR BRUSH REPLACEMENT..	2-41
2-29. TRANSISTOR REPLACEMENT..	2-34	2-36. LAMP REPLACEMENT.....	2-41
2-30. DC POWER SUPPLY REPAIR..	2-36	2-37. LAMP WIRE/CONNECTOR REPLACEMENT.....	2-42
2-31. DATA RECEIVER/SERVO POWER SUPPLY REMOVAL/ INSTALLATION.....	2-38	2-38. SOLID-STATE RELAY REPLACEMENT.....	2-44
2-32. DATA RECEIVER/SERVO POWER SUPPLY REPAIR...	2-39	2-39. THERMAL FUSE REPLACEMENT.....	2-44
2-33. HEAD FAN REPLACEMENT....	2-39	2-40. LAMP POWER SUPPLY REMOVAL/INSTALLATION..	2-45

2-27. TRANSISTOR TESTING

The B&K 510 Transistor Tester will identify faulty transistors through in-circuit checks made with the power removed from the circuit. The tester can also be used to test transistors which have been removed from the circuit.

Transistors used in the VARI*LITE luminaire are primarily the Bipolar Junction Transistor (BJT) type and are distinguished from the Field-Effect Transistor (FET) type by their basic construction and the names of their leads. A BJT type has three leads: collector, base, and emitter; and comes in the NPN variety and the PNP variety. To properly test and replace a BJT (or any transistor), it is necessary to be aware of the orientation of the leads and the variety or polarity of the transistor (NPN or PNP).

Transistors are also available in several package styles. The TO-3, TO-92, and TO-220 packages are used in the luminaire. The TO-3 is the large can style. The TO-92 is the small plastic style. The TO-220 is the power tab style. The lamp power supplies also use some small metal cans, the TO-18 style, and some medium sized metal cans, the TO-5 style.

Some of the devices used in the luminaire look like transistors, but they're not. The voltage regulators used on the servo power supply board; LM309, LM317 and LM337; are not transistors but three-terminal integrated circuits (ICs). These devices cannot be tested with the B&K Model 510.

Another device used in the lamp power supplies is the Silicon Controlled Rectifier (SCR). This device is similar in construction to a transistor, and looks just like one. The B&K Model 510 will test SCRs. Refer to the section in chapter 3 covering lamp power supply repair.

2-27. TRANSISTOR TESTING (CONT'D)

To use the tester, remove power from the circuit and proceed as follows:

NOTE

The micro-clip leads will not clip to a TO-3 package, but you may be able to hold the leads in place long enough to effect a test.

1. Connect the three micro-clip leads of the tester to the three leads of the transistor. It makes no difference which tester lead is connected to which transistor lead. However, ensure the tester leads are connected to the matching-color jacks on the tester: green lead to green jack and so forth.
2. Set the tester's OFF/LO/HI switch to LO. The TEST lamp should blink or one of the OK lamps may light. If no lamps light, replace the tester's batteries. Refer to the Transistor Tester Model 510 Instruction Manual for battery replacement.
3. Slide the TEST switch left and right through all of its settings until one of the OK lamps light and the TEST lamp goes out.
4. If neither OK lamp lights on any of the 6 settings, check your clip lead connections. Ensure the clips are securely connected to the transistor leads and no two clips are touching each other or otherwise shorting transistor leads together. Try the test with the OFF/LO/HI switch set to HI. If neither OK lamp lights the transistor is faulty and must be replaced. Refer to paragraph 2-29. Transistor Replacement.
5. If the NPN OK lamp lights, then the transistor has been identified as a good NPN transistor. If the PNP OK lamp lights, then the Transistor is a good PNP. Also the color code on the tester's front panel will identify the base, collector and emitter leads (BCE) depending on where the TEST switch is set when the OK lamp lights.
6. If you know for certain that the polarity identification (NPN or PNP) is wrong, or that the lead identification is wrong, the transistor may be faulty and should be replaced.

If you happen to have the B&K Dynaflex FP5 spring-loaded 3-prong transistor probe in your test rack, transistor testing can be simplified somewhat. Just remove the circuit card assembly from the luminaire, turn it over to the back side, and probe all the transistors from the back side. Using the probe can be tricky. You must get the tips lined-up just right and press down on the solder joints to make good contact, then hold it there while you operate the tester.

2-28. SOLDERING

Most of your solder connections will be between a wire or component lead and a conductive pad on a printed circuit board. A good solder joint will hold the component or wire securely to the PCB and make a low-resistance electrical connection. A good solder joint has a clean, shiny appearance.

To make a good solder joint:

- Both the component lead and the PCB pad must be clean;
- The lead or wire and the pad should make good mechanical contact;
- The lead or wire and the pad must be heated before the solder is applied.

Your soldering iron must have a clean, freshly tinned tip. A tinned surface has a layer of fresh solder applied over a cleaned portion of the iron. The shiny surface of a properly tinned tip will transfer heat much faster than the oxidized surface of a hot iron.

When the components are ready and the iron is hot, proceed as follows:

1. Apply the tip of the iron to the component lead or wire and the PCB pad so that both surfaces are heated at the same time.
2. Hold the solder against the point where the two heated surfaces touch, not against the tip of the iron.

CAUTION

Do not over heat semiconductor leads when soldering new components. Excessive heat can damage the component and/or the circuit board.

3. Remove the iron and solder as soon as the hot solder flows evenly over the hot metal surfaces. Use only enough solder to cover the pad.
4. Hold the component lead or wire motionless until the solder joint cools.

NOTE

If the joint is moved before it becomes solid, the solder may crystallize and lose its holding ability. Soon you will have to repair a cracked or broken solder joint that has caused the VARI*LITE luminaire to fail.

2-28. SOLDERING (CONT'D)

5. Clean any excess solder from the soldering iron tip. Use a damp sponge or a damp paper towel. (A sponge is an excellent accessory for your soldering outfit; if get your hands on one, don't let go).

A poor solder joint exhibits any or all of the following:

- Huge globs of solder on the joint.
- Spikes or whiskers of solder extending from the joint.
- A dull, gray surface on the joint.
- Bubbles of brown flux all around the joint.

Never re-heat old solder to repair a poor solder joint. Solder that has been heated and cooled several times oxidizes, crystallizes, and loses its holding ability. Desolder the joint using solder wick and a hot iron and re-make the joint properly.

De-soldering

To de-solder a joint, when removing faulty components or repairing a faulty solder joint, remove the old solder with a hot soldering iron and a solder sucker. Proceed as follows:

1. Ensure solder sucker is empty and free of old, loose solder.
2. Press plunger to cock solder sucker.
3. Place the freshly tinned tip of a hot soldering iron on the old solder joint.
4. When the solder melts, place the tip of the solder sucker over the molten solder and press the plunger release. Remove the component lead or wire, as required.
5. Remove the iron and the solder sucker from the joint. Empty the old solder from the sucker.
6. Repeat steps 1 thru 5 until the hole in the PCB pad is clear.

2-29. TRANSISTOR REPLACEMENT

Transistor replacement is similar to replacement of passive components such as resistors and capacitors in that the old device must be desoldered and removed, and the new device must be inserted and soldered in-place. Refer to paragraph 2-28. Soldering, for instructions on using a soldering iron without destroying both the component and the printed circuit board.

2-29. TRANSISTOR REPLACEMENT (CONT'D)

The principal distinctions in replacing transistors are identifying by type or part number, and orientation of the leads: collector, base and emitter. The illustration shows how to identify the leads of the various package types used in the luminaire.

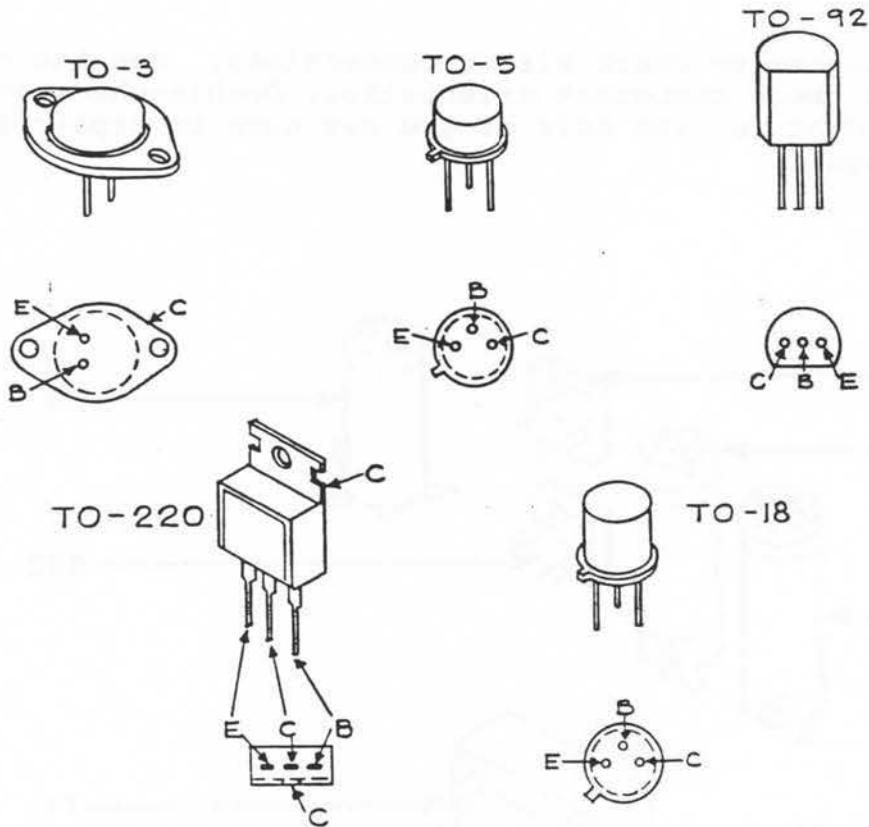

Many of the circuits, especially the servo circuits, employ pairs of similar transistors: a PNP and an NPN. Check the part numbers carefully when replacing transistors in these (or any circuits) since a PNP type will not work in a circuit designed for an NPN (and vice versa). The transistor may even be destroyed if installed in the wrong circuit.

CAUTION

Do not over heat semiconductor leads when soldering new components. Excessive heat can damage the component and/or the circuit board.

To remove and replace one of the large transistors or voltage regulators, remove the circuit card assembly. Then unsolder the component and remove the mounting hardware. Install the new component, properly oriented, with the mounting hardware. Then resolder the connections using the soldering iron.

2-30. DC POWER SUPPLY REPAIR

To replace a component in the dc power supply, disconnect the wiring, unscrew the mounting hardware, and remove the component. When installing the new component, be sure to orient the component properly, use new lock washers in the mounting hardware, and connect the wiring properly.

See the wiring diagram to check wiring connections. See the component layout diagram to check component orientation. Double-check everything before applying power to the unit or you may have to repair the power supply all over again.

Component Layout

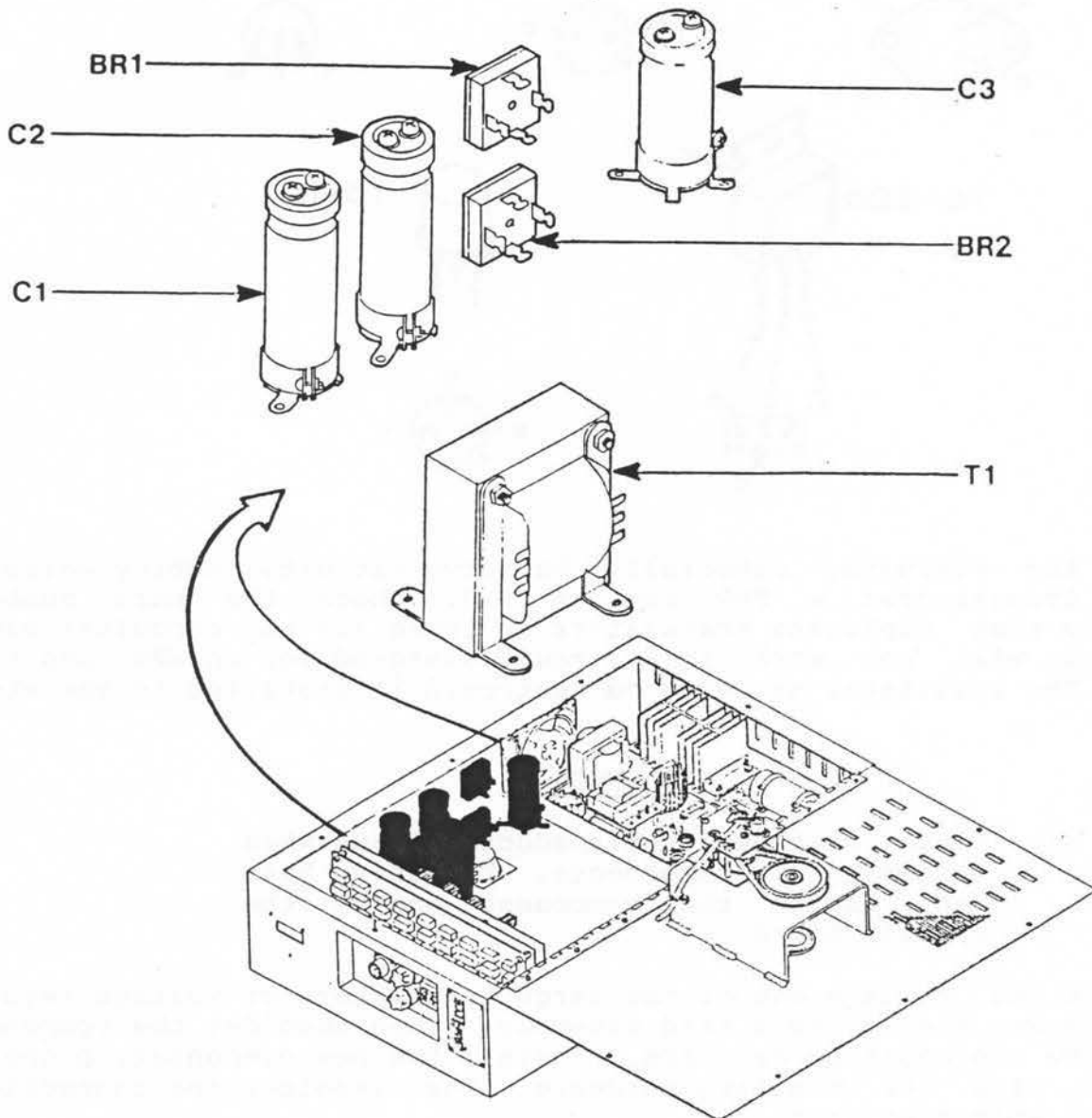

2-30. DC POWER SUPPLY REPAIR (CONT'D)

Wiring Diagram

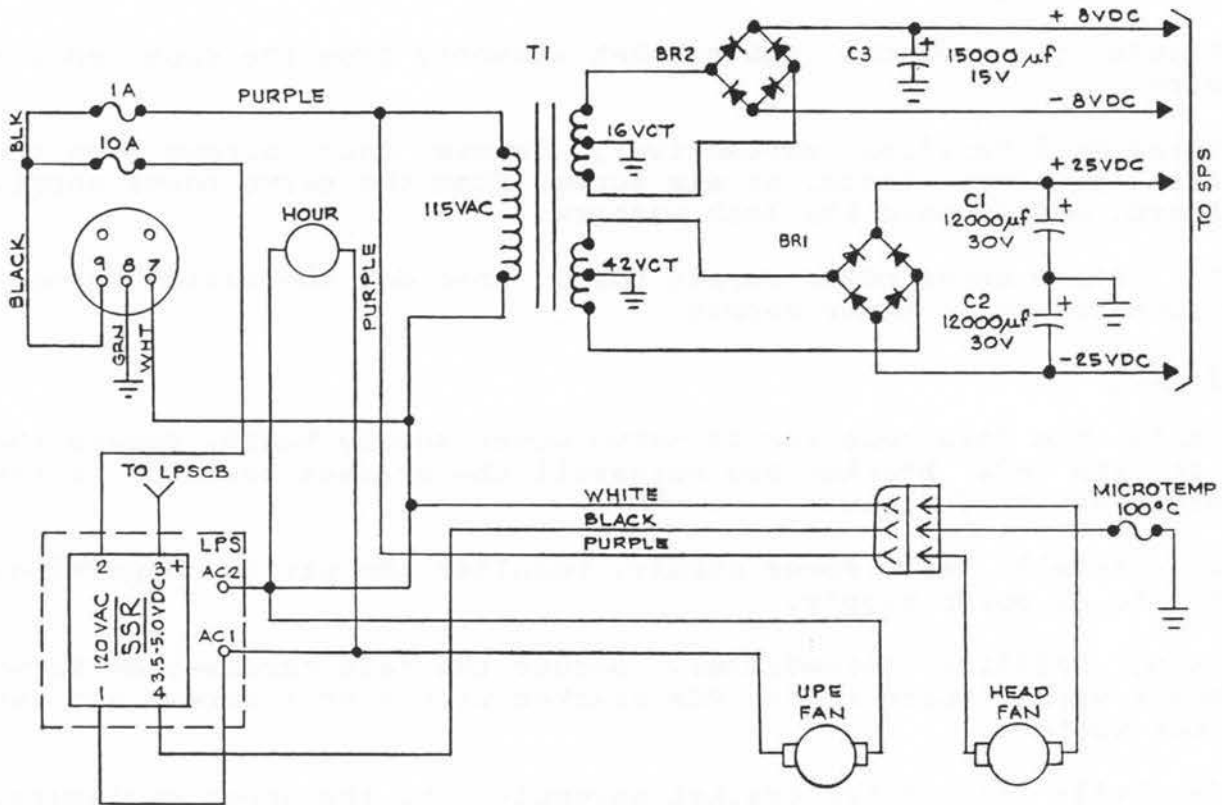

2-31. DATA RECEIVER/SERVO POWER SUPPLY REMOVAL/INSTALLATION

Removal

To remove the data receiver or servo power supply board, you must remove the PCB bracket assembly to which the servo power supply and data receiver boards are mounted.

1. Using No.2 Phillips screwdriver, remove the six screws holding the PCB bracket assembly to the top of the upper enclosure.
2. Disconnect the red IDC connectors from both boards. Take note of which connectors go to which board, as the connectors are NOT interchangeable.
3. Carefully remove the PCB bracket assembly from the upper enclosure.
4. Using No.2 Phillips screwdriver, remove four screws from the data receiver board, or six screws from the servo power supply board, and discard the lock washers.
5. To remove servo power supply board, unsolder the wiring connections to the dc power supply.

Installation

To install the data receiver or servo power supply board, secure the board to the PCB bracket and reinstall the bracket assembly in the upper enclosure as follows:

1. To install servo power supply, resolder the wiring connections to the dc power supply.
2. Using Phillips screwdriver, secure the data receiver or servo power supply board to the PCB bracket with 4 or 6 screws and new lock washers.
3. Carefully insert the bracket assembly into the upper enclosure. Be sure all the cable assemblies and wires are properly routed, not caught under the bracket.
4. Connect all the red IDC connectors to the appropriate circuit board connectors. Be careful not to reverse the connections between the two boards, as the connectors on the two ends are NOT interchangeable.
5. Using No.2 Phillips screwdriver, secure the PCB bracket assembly to the upper enclosure with six screws.

2-32. DATA RECEIVER/SERVO POWER SUPPLY REPAIR

Integrated Circuits

To remove and replace an Integrated Circuit (IC), remove the servo power supply board as described above. Pop the bad IC out of its socket with a small screwdriver. Observe the pin 1 marker on the new IC and carefully plug the IC into its socket. Be sure you don't bend the leads or install the IC backwards.

Heat Sink-Mounted Components

CAUTION

Do not over heat semiconductor leads when soldering new components. Excessive heat can damage the component and/or the circuit board.

To remove and replace one of the large transistors or voltage regulators, remove the servo power supply board as described above. Then unsolder the component and remove the mounting hardware. Install the new component, properly oriented, with the mounting hardware. Then resolder the connections using the soldering iron.

Resistors/Capacitors/Diodes

To remove and replace any other component, remove the servo power supply board as described above. Unsolder and remove the component. Install the new component, properly oriented as required, and resolder the connections.

2-33. HEAD FAN REPLACEMENT

WARNING

115 Vac may be present within the VARI*LITE luminaire. Remove power from the luminaire before proceeding.

Head assembly fan will not run:

1. Check 1.5 A fuse.
2. Check for broken wires.
3. Check for bad connector.
4. Replace fan.

2-33. HEAD FAN REPLACEMENT (CONT'D)

To replace fan in head assembly:

1. Unplug 3-pin connector.
2. Remove 4 screws.
3. Remove and replace fan.
4. Secure fan with 4 screws.
5. Plug in connector.

2-34. UPE FAN REPLACEMENT

WARNING

115 Vac may be present within the VARI*LITE luminaire. Remove power from the luminaire before proceeding.

Upper enclosure fan won't run:

1. Check 10 A fuse.
2. Check thermal fuse.
3. Check solid-state relay.
4. Replace fan.

To replace fan in upper enclosure:

1. Remove the 4 screws that secure the lamp power supply (LPS). Slide the LPS away from the fan.
2. Remove the 3 screws that secure the fan to the upper enclosure.
3. Unsolder the wires from the old fan.
4. Solder the wires to the new fan.
5. Clean the dust/dirt off the grille. Hold the clean grille in place over the inside of the fan opening.
6. Install the new fan with the label facing the outside of the UPE.
7. Secure the fan with 3 screws.
8. Secure the LPS to its standoffs with 4 screws.

2-35. MOTOR BRUSH REPLACEMENT

If the motor is getting power to the terminals but will not run, check the brushes and replace as required:

1. Using a small, flat-blade screwdriver, unscrew the plastic plugs securing the motor terminal and remove the brushes.
2. Check brushes for wear or damage. Brushes should be about 3/16 inch long with slight curve at far end where they meet the motor commutator. Replace if broken or pitted.
3. To replace, cut wires from old brush(es).
4. Fit new brush(es) in motor and secure with plastic plug.
5. Strip wire(s) and solder to terminal(s). See para. 2-54 for wiring connections.

2-36. LAMP REPLACEMENT

To remove and replace the GE Marc 350 lamp:

1. Remove power from the lamp power supply (LPS); either douse the lamp from the control console, set mini-controller LAMP switch to OFF, or disconnect the 9-pin lamp cable connector from the luminaire.
2. Open the rear door.
3. Unplug lamp power connector.

CAUTION

If lamp has been lit the base may be hot.
The reflector will be quite hot, so watch
your fingers.

4. Remove lamp retainer assembly from base of lamp and remove lamp.
5. Fit new lamp to lamp bracket assembly and secure with lamp retainer assembly.
6. Plug in lamp power connector. Close rear door.
7. If the old lamp has exploded, check head assembly and especially the FFA for fragments. Remove all lamp fragments from FFA and other head assembly components. Disassemble FFA as required (para. 2-52).

2-37. LAMP WIRE/CONNECTOR REPLACEMENT

Lamp Wires

To replace lamp wires:

1. Remove FFA (para. 2-49).
2. Unplug the 3-pin connectors in the head assembly and in the upper enclosure.
3. Remove pins from the connector in the head assembly.
4. Cut ty-wraps securing yoke cables (multi-core and lamp wires).
5. Remove old lamp wires.
6. Thread new wires, one at a time, through spring protector in yoke down tube.
7. Route wires up the side of the yoke as shown.

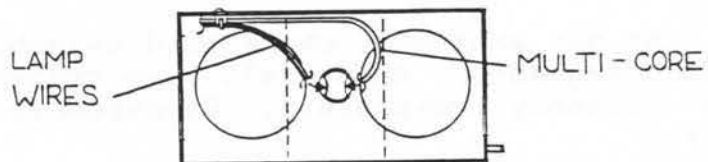
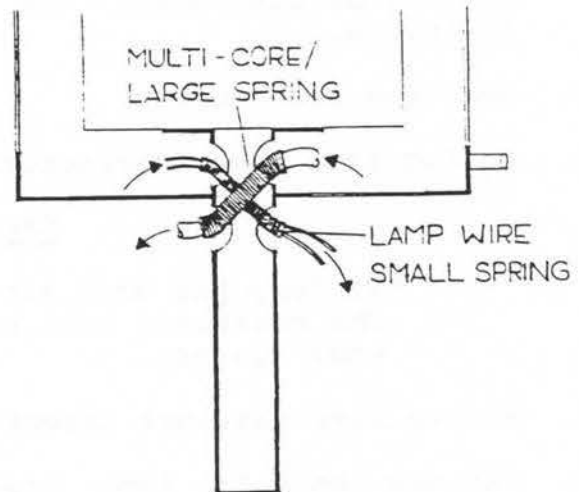
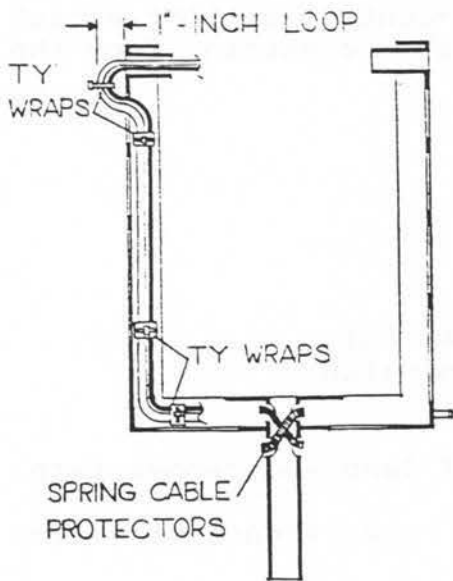

2-37. LAMP WIRE/CONNECTOR REPLACEMENT (CONT'D)

Lamp Wires (cont'd)

8. Fit wires into side of head assembly.
9. Strip wires about 1/4 inch at each end. Crimp new connector pins on the ends. Solder the crimped pins to the wires.
10. Insert pins into connectors, black wire in pin 1, red wire in pin 3.
11. Measure wire length with service loop as shown. Secure wires to head assembly side rail with ty-wrap.
12. Measure outside service loop as shown. Secure lamp wires and multi-core cable to yoke with ty-wraps.
13. Wrap lamp wires around pan bracket as shown. Secure lamp wires and multi-core cable with ty-wrap.
14. Plug the yoke down tube with clear RTV.
15. Plug in connectors.
16. Reinstall FFA (para. 2-49).

Connector/Pins

To replace a 3-pin connector, remove the pins from the connector and insert pins in a new connector. Be sure to put the black wire in pin 1 and the red wire in pin 3.

To replace connector pins:

1. Remove pins from connector.
2. Cut off old pins.
3. Strip wires about 1/4 inch.
4. Crimp and solder new pins to wires.
5. Insert pins into connector; black wire in pin 1, red wire in pin 3.

2-38. SOLID-STATE RELAY REPLACEMENT

To replace the solid-state relay:

WARNING

115 Vac may be present at relay terminals. Remove power from the luminaire before proceeding.

1. Remove lamp power supply (para. 2-40).
2. Unplug quick-disconnects from faulty relay.
3. Using No.1 Phillips screwdriver, remove 2 screws and nuts from faulty relay. Remove relay.
4. Apply a thin, even coating of heat sink compound (the white, lithium grease) to the underside of the new relay.
5. Secure new relay to LPS with 2 screws and Keps nuts..
6. Connect wires to new relay as before.
7. Reinstall lamp power supply (para. 2-40).

2-39. THERMAL FUSE REPLACEMENT

To replace a blown thermal fuse:

1. Loosen screw and disconnect fuse from heat shield.
2. Cut wire just at the end of the crimp connection.
3. Crimp new spade lug on one end of new thermal fuse.
4. Crimp new butt connector on other end of fuse.
4. Strip wire about 3/8 inch and crimp to butt connector.
5. Secure spade lug to heat shield with screw.

VARI*LITE
02-3002-0002

2-40. LAMP POWER SUPPLY REMOVAL/INSTALLATION

The lamp power supply (LPS) and lamp power supply control board (LPSCB) should be removed/installed as a unit. Keep these together at all times to avoid using the wrong LPSCB with any given LPS.

Removal

WARNING

● 115 Vac may be present within the VARI*LITE luminaire. Remove power from the luminaire before proceeding.

● Big blue or silver 820 uf capacitor on EM11 or EM12 LPS may be charged. To avoid dangerous shock, discharge capacitor by shorting across terminals with insulated-handle tool before proceeding.

1. Disconnect the 6-pin IDC from LPSCB P2.
2. Disconnect the 3-pin connector from the yoke cable assembly.
3. Unplug the 2 quick-disconnects from LPS terminals AC1 and AC2.
4. Unplug 3 quick-disconnects from solid-state relay terminals 1, 2 and 4.
5. Cut the ty-wraps from the wire bundle over the LPS.
6. Remove 2 nuts securing the LPSCB. Remove the LPSCB from the standoffs.
7. Remove 2 screws securing the stand-offs to the UPE.
8. Remove 4 screws securing the LPS. Slide the LPS away from the UPE fan.
9. Remove the LPS and LPSCB from the enclosure.

2-40. LAMP POWER SUPPLY REMOVAL/INSTALLATION (CONT'D)

Installation

1. Fit the replacement LPS and LPSCB into the upper enclosure.
2. Reinstall stand-offs and secure with 2 screws.
3. Secure LPS to enclosure with 4 screws.
4. Secure LPSCB to standoffs with 2 nuts.
5. Plug quick disconnects onto solid-state relay:
 - Black wire to terminal 4;
 - Blue wire from fuse holder to terminal 2;
 - Blue wire from AC1 connector to terminal 1.

NOTE

On EMI1 supplies, make no connection to terminal marked AC2-F. This terminal is not connected to anything.

6. Plug quick-disconnects onto LPS ac inputs:
 - Blue wires to AC1, or AC HI;
 - White wires to AC2, or AC LO.
7. Plug the 3-pin connector to the yoke cable assembly.
8. Plug the 6-pin IDC to LPSCB P2.
9. Gather wire slack and, keeping lamp wires separate from all other wires, secure the other wires with ty-wraps.

Section VII. IRIS BULKHEAD ASSEMBLY

<u>Paragraph</u>	<u>Page</u>	<u>Paragraph</u>	<u>Page</u>
2-41. IRIS BULKHEAD REMOVAL/ INSTALLATION.....	2-47	2-45. IRIS ARM GEAR ASSEMBLY..	2-49
2-42. IRIS MOTOR REPLACEMENT..	2-47	2-46. LEAF REPLACEMENT.....	2-50
2-43. IRIS CLUTCH ADJUSTMENT..	2-48	2-47. IRIS CLEANING AND LUBRICATION.....	2-51
2-44. IRIS FEEDBACK POT.....	2-49	2-48. POD REPLACEMENT.....	2-52

2-41. IRIS BULKHEAD REMOVAL/INSTALLATION

Removal

1. Unplug IDC from wheel servo board P8.
2. Remove 2 screws securing iris bulkhead to head assembly side rails.
3. Slide iris bulkhead out of head assembly.

Installation

1. Slide iris bulkhead into notches cut in head assembly side rails.
2. Secure iris bulkhead to head assembly with 2 screws.
3. Route cable assembly between FFA bulkhead and lens retainer.
4. Plug IDC onto wheel servo board P8.

2-42. IRIS MOTOR REPLACEMENT

Removal

1. Remove iris bulkhead assembly (para. 2-41).
2. Remove 4 screws securing outer bearing plate.
3. Remove outer bearing plate, turning plate to clear motor brush.
4. Cut wires and remove motor. Save old motor for return to the shop.

2-42. IRIS MOTOR REPLACEMENT (CONT'D)

Installation

5. Position new motor in bracket.
6. Fit outer bearing plate over new motor and secure with 4 screws. Tighten screws until snug.
7. Strip wires and solder to motor as shown.
8. Grease worm gear.

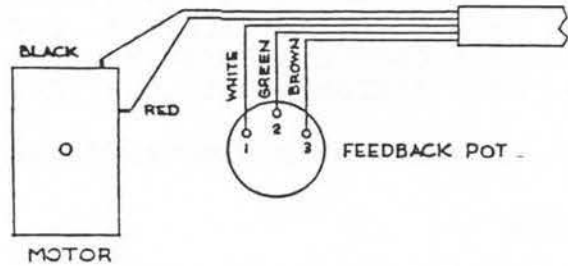

Adjust Gear Mesh

9. Loosen screws securing outer bearing plate.
10. Slide motor up or down slightly to adjust gear mesh. Clutch gear should rock back and forth slightly.
11. Tighten screws in front bearing plate to secure motor and preserve gear adjustment.
12. Reinstall iris bulkhead assembly (para. 2-41).

2-43. IRIS CLUTCH ADJUSTMENT

1. Remove 4 screws securing front bearing support plate. Remove plate.
2. Remove worm gear/clutch assembly.
3. Screw hex nuts in/out to tighten/loosen clutch.
4. Reassemble worm gear/clutch and front bearing support plate. Secure with 4 screws.

2-44. IRIS FEEDBACK POT

Removal

1. Loosen set screw in feedback pot gear.
2. Loosen nut securing feedback pot to bulkhead and remove pot.
3. Replace gear as required.
4. Replace pot as required:
 - a. Cut wires from old pot.
 - b. Strip wires about 1/4 inch.
 - c. Solder wires to new pot.

Installation

1. Position feedback pot on bulkhead as shown. Secure with washer and nut.
2. Plug iris assembly connector to wheel servo board P8.
3. Press mini-controller ADDRESS switch to address luminaire.
4. Turn INTENSITY control fully CCW to close iris.
5. Turn shaft of feedback pot until iris is closed in an approximate zero position.
6. Install gear and tighten set screw.

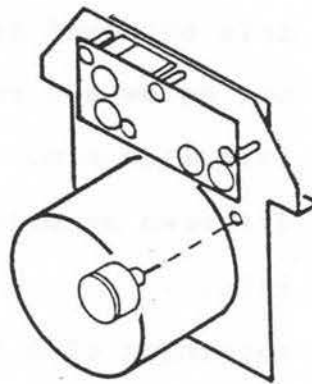

2-45. IRIS ARM GEAR ASSEMBLY

Removal

1. Loosen set screw and remove collar from iris actuating lever.
2. Loosen set screw in iris arm gear assembly.
3. Remove iris arm gear assembly.
4. Remove iris link arm from arm gear.

2-45. IRIS ARM GEAR ASSEMBLY

Installation

1. Clip iris link arm to arm gear.
2. Install arm gear on motor shaft and link arm on iris actuating lever.
3. Tighten set screw in to secure arm gear.
4. Install collar on iris actuating lever. Ensure link arm is straight, parallel to bulkhead. Tighten set screw to secure.

2-46. IRIS LEAF REPLACEMENT

Removal

1. Remove iris bulkhead assembly (para. 2-41).
2. Loosen set screw and remove collar from iris actuating lever.
3. Remove iris link arm.
4. Loosen 4 screws securing iris to bulkhead. Remove POD.
5. Remove iris.
6. Remove retaining clip from inner diaphragm.
7. Separate inner and outer iris diaphragms.
8. Remove leaves. Inspect leaves for burned places and other damage. Replace leaves as required.

Installation

1. Place pin on rounded end of leaf into one of the small holes in outer diaphragm.
2. Check pin on the other end and fit leaf into outer diaphragm in fully open position.
3. Install the other leaves the same way, all the way around. Lay each leaf over the head of the previous one. Slide overlapping leaves under the tails of the first ones.

2-46. IRIS LEAF REPLACEMENT (CONT'D)

Installation (cont'd)

4. Install inner iris diaphragm:
 - a. Fit actuating lever through slot in outer diaphragm.
 - b. Rotate inner diaphragm CW to the fully open position.
 - c. Set inner diaphragm into outer diaphragm.
 - d. Fit leaf pins into slots in inner diaphragm.
 - e. Tap iris lightly to jostle pins into slots.
 - f. Work actuating lever to verify all leaves are properly positioned.
5. Install retaining clip.
6. Sprinkle graphite on iris. Work lever back and forth, opening and closing iris, to lubricate leaves.
7. Position iris on bulkhead. Center slot between spacers.
8. Fit washers over iris diaphragm and tighten 3 screws.
9. Install POD (para. 2-48).
10. Install iris link arm.
11. Fit collar on iris actuating lever. Ensure link arm is straight, parallel to bulkhead. Tighten set screw to secure.
12. Install iris bulkhead assembly (para. 2-41).

2-47. IRIS CLEANING AND LUBRICATION

1. Remove iris bulkhead assembly (para. 2-41).
2. Remove iris (para. 2-46, Removal steps 2 -- 9).
3. Apply organic solvent to iris with leaves closed. Wipe leaves until clean.
4. Sprinkle graphite on iris. Work actuating lever back and forth to lubricate leaves.
5. Install iris (para. 2-46, Installation steps 7 -- 11).
6. Install iris bulkhead assembly (para. 2-41).

2-48. POD REPLACEMENT

1. Remove iris bulkhead assembly (para. 2-41).
2. Loosen screw securing POD to iris. Remove POD.
3. Install new POD with shiny side facing the lamp.
4. Close the iris and position POD carefully over iris opening (pupil).
5. Bend POD arm as required to correct POD position.
6. Tighten screw. Check POD position.
7. Reinstall iris bulkhead assembly (para. 2-41).

Section VIII. FILTER/FOCAL ASSEMBLY

<u>Paragraph</u>	<u>Page</u>	<u>Paragraph</u>	<u>Page</u>
2-49. FFA REMOVAL/ INSTALLATION.....	2-53	2-53. FILTER/BEAM WHEEL DISASSEMBLY.....	2-56
2-50. WHEEL MOTOR REPLACEMENT.....	2-54	2-54. FILTER/APERTURE/GOBO REPLACEMENT.....	2-57
2-51. WHEEL FEEDBACK POT.....	2-54	2-55. HUB GEAR.....	2-59
2-52. FFA DISASSEMBLY.....	2-55	2-56. FFA REASSEMBLY.....	2-59

2-49. FFA REMOVAL/INSTALLATION

Removal

1. Remove fan (para. 2-33).
2. Remove wheel servo board as follows: unplug all 9 IDC connectors; remove 4 screws; and remove board.
3. Remove lamp (para. 2-36).
4. Remove 2 nuts securing each FFA shroud cap. Remove the shroud caps.
5. Remove 2 screws securing each heat baffle. Remove the heat baffles.
6. Remove 4 screws securing FFA bulkheads to side rails. Slide FFA out of head assembly.

Installation

1. Slide FFA into notches cut in side rails. Secure FFA with 4 screws.
2. Position heat baffles on side rails. Secure upper baffle with 2 screws. Secure lower baffle, thermal fuse, and ground wire with 2 screws.
3. Fit shroud caps over wheels with louvers opening to the rear. Secure shroud caps with 2 nuts on each cap.
4. Install lamp (para. 2-36).
5. Position wheel servo board on standoffs with tall heat sinks forward. Secure with 4 screws.

2-49. FFA REMOVAL/INSTALLATION (CONT'D)

Installation (cont'd)

6. Plug-in IDC connectors to wheel servo board as follows:

- P1 : 6-pin control signal input.
- P2 : 3-pin +/-20 volts input.
- P3 : 5-pin wheel 1 connector.
- P4 : 5-pin wheel 2 connector.
- P5 : 5-pin wheel 3 connector.
- P6 : 5-pin wheel 4 connector.
- P7 : 5-pin tilt assy connector.
- P8 : 5-pin iris assy connector.
- P9 : 5-pin +/-15 and +/-12 volts input.

7. Reinstall fan (para. 2-33).

2-50. WHEEL MOTOR REPLACEMENT

1. Remove Filter/Focal Assembly (FFA) as required (para. 2-49).
2. Remove 2 screws from motor mounting plate.
3. Cut wires and remove motor/plate assembly.
4. Remove 2 screws from motor/plate assembly. Save the old motor for return to the shop.
5. Fit new motor to mounting plate and secure with 2 screws.
6. Fit motor/plate assembly to bulkhead and secure with 2 screws.
7. Strip wires and solder to motor. See para. 2-54 for motor wiring.
8. Adjust gear mesh (para. 2-25 step 6).
9. Reinstall FFA (para. 2-49).
10. Calibrate FFA (para. 2-25).

2-51. WHEEL FEEDBACK POT

Removal

1. Loosen set screw in feedback pot gear.
2. Loosen nut securing pot to mounting plate.
3. Remove pot from bulkhead.
4. Cut or unsolder wires from pot terminals.

2-51. WHEEL FEEDBACK POT (CONT'D)

Installation

1. If a black VRN pot has been removed, and a blue and silver Bourns pot is replacing it, check for and remove the press-fit bearing in the mounting hole.
2. Position the new pot in the mounting hole. Tighten nut to secure pot.
3. Strip wires about 1/4" and solder to pot terminals. See para. 2-54 for pot wiring.
4. Install gear on pot shaft. Tighten set screw to secure gear.
5. Calibrate FFA (para. 2-25).

2-52. FFA DISASSEMBLY

1. Remove FFA (para. 2-49).
2. Remove 2 screws securing lens retainer to lens standoffs. Remove retainer, lens and spacer.
3. Loosen 2 screws securing lamp retainer springs to lamp bracket assembly.
4. Unscrew 2 lamp standoffs securing lamp bracket assembly to bulkhead. Remove lamp bracket assembly.
5. Remove 4 screws from bulkheads.
6. Carefully separate bulkheads. The shafts should be glued to one of the bulkheads. Pull bulkheads straight apart. Do not flex assembly and distort gear wheels before wheels unmesh with motor and feedback pot gears.
7. To remove wheels, tap the glued ends of the shafts to break bond. If glue bonds will not break, disassemble wheel/shaft assembly and carefully flex shafts side-to-side to remove.

NOTE

Check serial number written on FFA bulkhead to determine in which generation the assembly was manufactured.

2-53. FILTER/BEAM WHEEL DISASSEMBLY

To disassemble wheels, disassemble FFA (para. 2-52) and proceed as follows:

1. Using snap ring pliers (for external retaining rings), remove snap rings (1) from end of shaft.
2. Remove bronze thrust bearing (2).
3. Remove neoprene (black) or rubber (red) washer (3).
4. Remove filter wheel assembly (4), (wheel, hub gear, finger spring, bronze bearing).
5. Remove and clean teflon washer (5).

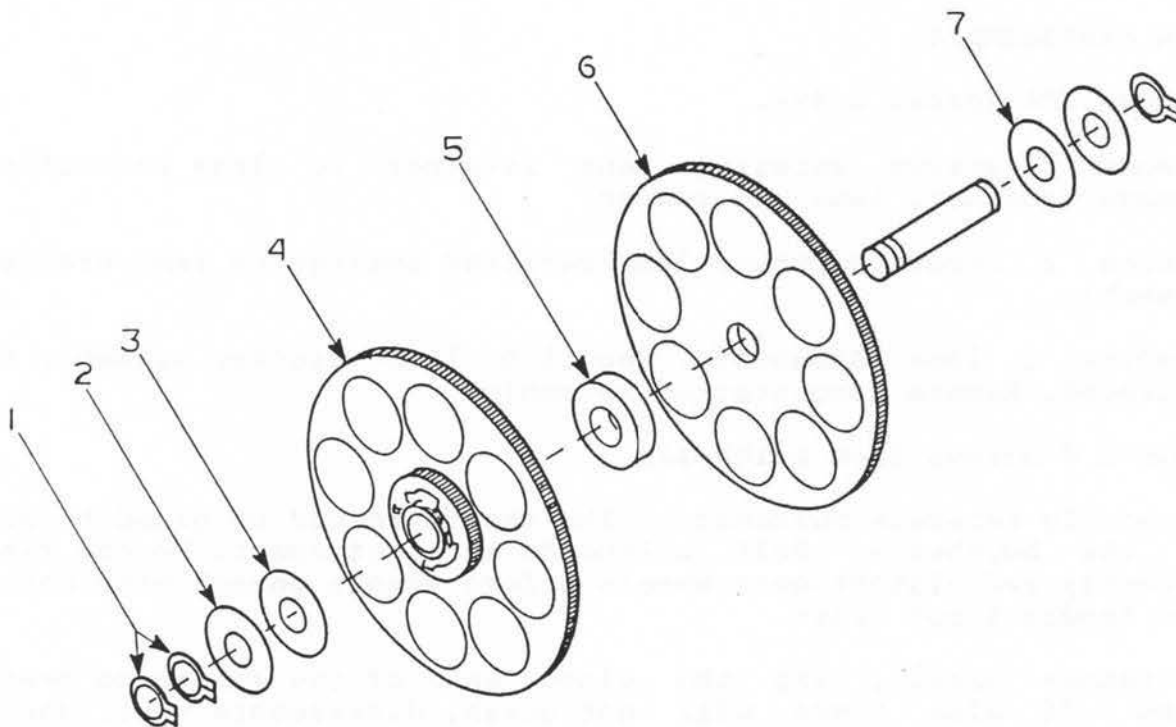

NOTE

If you are disassembling the wheels with shafts still glued to the bulkhead, you must now repeat steps 1 thru 5 to remove filter wheel assembly from the other shaft.

6. Remove the other filter wheel assembly (6) and neoprene (or rubber) washer (7).
7. To replace shaft, remove the remaining pieces: bronze thrust bearing and snap ring(s); remove and/or discard old shaft.

2-54. FILTER/APERTURE/GOBO REPLACEMENT

To replace filters, apertures, or gobos, disassemble filter/beam wheels (para. 2-53) and proceed as follows:

1. Push the old item out with finger or tool. In case of broken filter, carefully remove all pieces and don't cut yourself.
2. Remove old RTV adhesive from filter mounting position.
3. Clean wheel.

NOTE

Filters must be installed with the coated side facing toward the lens and away from the lamp. Apertures/gobos must be installed with the black side facing the lens and the shiny side facing the lamp.

4. Fit new filter/aperture/gobo in position. See the illustration to determine where the correct position is. Note that when you hold the filter with the coated side down, you can see the edge of the glass disk reflected in the backside of the coating. Aluminum apertures/gobos shall be replaced with new chrome-plated steel items.
5. Secure filters with 2 small beads of clear RTV as shown. Secure apertures/gobos with 2 small beads of red (high-temp) RTV around the edge of the aperture/gobo as shown. Install snap-ring on top of apertures/gobos (gobo wheel positions 5, 6 & 7).

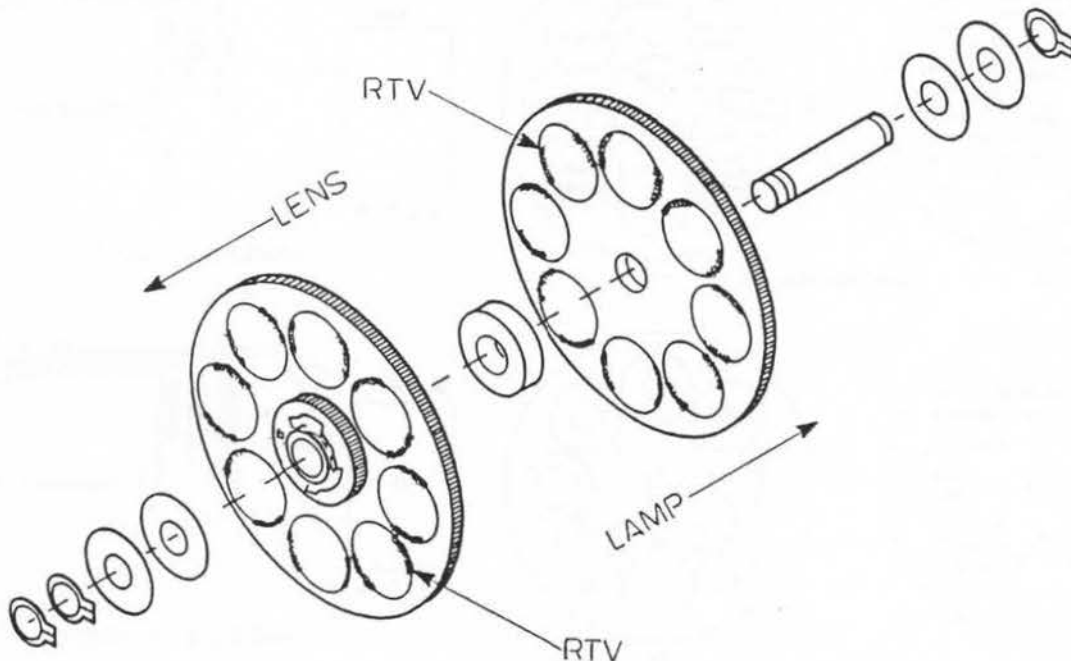

6. Reassemble filter/beam wheels and FFA (para. 2-56).

2-54. FILTER/APERTURE/GOBO REPLACEMENT (CONT'D)

Sixth Generation Filter/Beam Wheels (S/N 96065xxx)

6 TH GENERATION

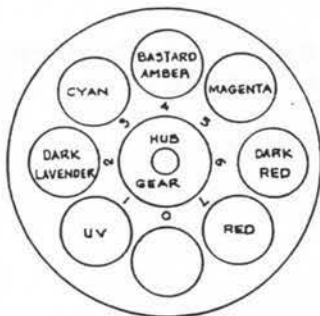

#1 (COATED SIDE UP)

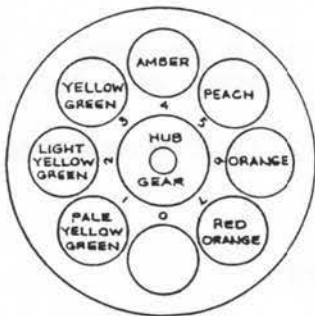

#2

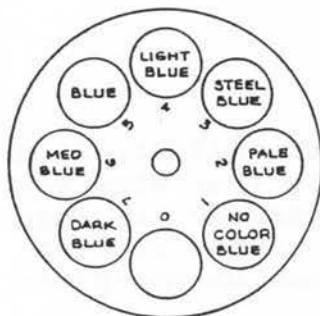

#3 (COATED SIDE UP)

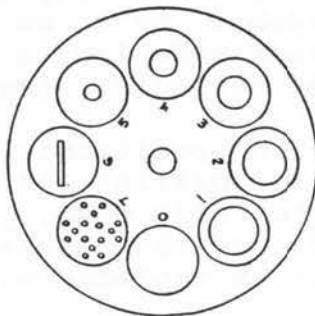

#4 (SHINY SIDE DOWN)

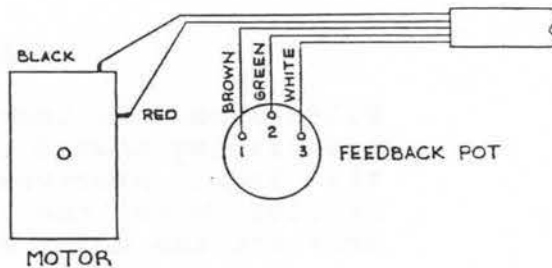

First thru Fifth Generation Filter/Beam Wheels (S/N 96040xxx-96064xxx)

1ST THRU 5TH
GENERATION

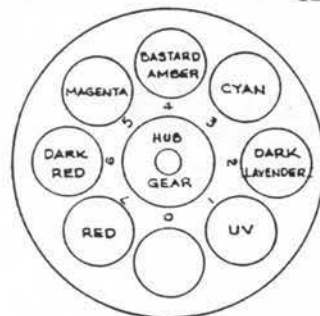

#1 (COATED SIDE UP)

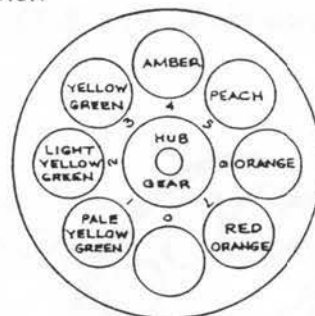

#2

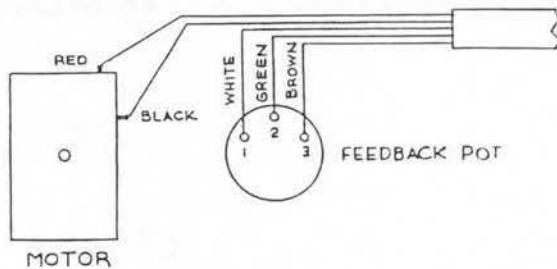

WHEELS 1 AND 3

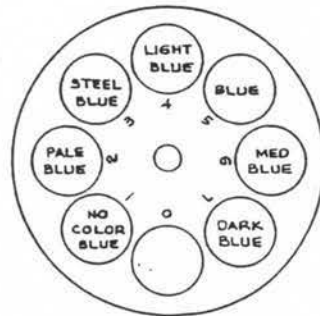

#3 (COATED SIDE UP)

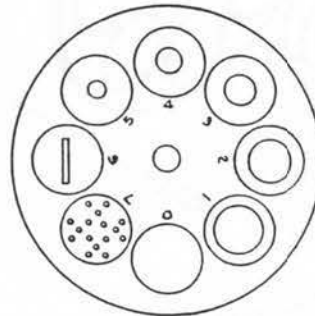

#4 (SHINY SIDE DOWN)

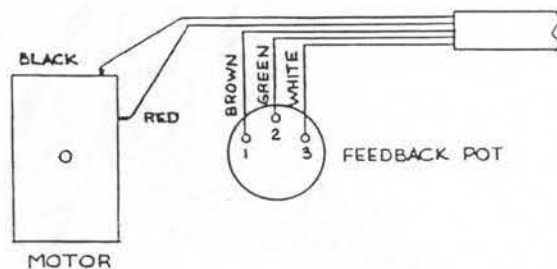

WHEELS 2 AND 4

2-55. HUB GEAR

If the hub gear slips with respect to the gear wheel, re-glue hub gear as follows:

1. Disassemble filter wheels (para. 2-53).
2. Separate hub gear from gear wheel. Finger spring and bronze bearing will remain with hub gear.
3. Spray Activator 707 on mating surface of hub gear. Allow 3 to 5 minutes drying time.
4. Apply SpeedBonder 325 to one surface and assemble immediately. Allow 3 minutes to cure adhesive.
5. Remove excess adhesive with organic solvent.

2-56. FFA REASSEMBLY

Filter/Beam Gear Wheel

1. Install snap ring(s) on one end of shaft.
2. Fit bronze thrust bearing on shaft.
3. Fit rubber washer on shaft over bearing. Replace neoprene washer with new rubber washer, as required.
4. Fit gear wheel on shaft.
5. Fit clean teflon washer on shaft.
6. Fit second gear wheel on shaft.
7. Install new rubber washer and bronze thrust bearing on shaft.
8. Secure the end of the shaft with snap ring(s).

Bulkhead Assembly

9. Fit gear wheel assemblies into bulkhead.
10. Align shafts and bulkhead. Fit bulkheads together. Secure bulkheads with 4 screws.
11. Install lamp bracket assembly. Screw-in standoffs finger-tight. Tighten 2 screws to secure bracket and lamp retainer springs.
12. Install lens and lens retainer. Secure with 2 screws. Re-glue spacer as required.

Section IX. PAN AND TILT ASSEMBLIES

<u>Paragraph</u>	<u>Page</u>	<u>Paragraph</u>	<u>Page</u>
2-57. TILT BRACKET REMOVAL/ INSTALLATION.....	2-60	2-60. PAN/TILT CLUTCH ADJUSTMENT.....	2-62
2-58. PAN BRACKET REMOVAL/ INSTALLATION.....	2-61	2-61. PAN/TILT FEEDBACK POT...	2-62
2-59. PAN/TILT MOTOR REPLACEMENT.....	2-61	2-62. PULLEY REMOVAL/ INSTALLATION.....	2-63
		2-63. BELT REPLACEMENT.....	2-64

2-57. TILT BRACKET REMOVAL/INSTALLATION

Removal

1. Remove iris bulkhead assembly (para. 2-41).
2. Remove FFA (para. 2-49).
3. Remove the side shroud from over tilt pulley.
4. Using No.1 Phillips screwdriver, remove 2 screws and nuts securing heat shield behind tilt pulley. Remove heat shield.
5. Using No.2 Phillips screwdriver, remove 2 screws and nuts securing tilt bracket. Remove tilt bracket and remove belt from tilt pulley.

Installation

1. Position tilt bracket in head assembly side rail.

NOTE

Hex nuts used to secure tilt bracket are difficult to get to during installation. Use spare iris link arm as tool to hold nut in place while tightening screw. Or use RTV to secure nut to inner bearing plate prior to installation.

2. Secure tilt bracket with 2 screws and nuts.
3. Apply power to luminaire (without data) to zero the tilt motor.
4. Fit belt over tilt pulley.
5. Position heat shield in side rail behind tilt pulley. Secure heat shield with 2 screws and nuts.
6. Fit side shroud over tilt pulley.

2-57. TILT BRACKET REMOVAL/INSTALLATION (CONT'D)

Installation (cont'd)

7. Reinstall FFA (para. 2-49).
8. Reinstall iris bulkhead assembly (para. 2-41).

2-58. PAN BRACKET REMOVAL/INSTALLATION

Removal

1. Remove 2 nuts securing pan bracket.
2. Remove belt from pulley and remove bracket.

Installation

1. Position pan bracket over studs. Install 2 nuts on studs.
2. Fit belt over pulley.
3. Slide pan bracket away from pulley to tension the belt. Tighten 2 nuts to secure bracket.

2-59. PAN/TILT MOTOR REPLACEMENT

To remove tilt motor, first remove tilt bracket from head assembly (para. 2-57) and proceed. To remove pan motor, proceed as follows:

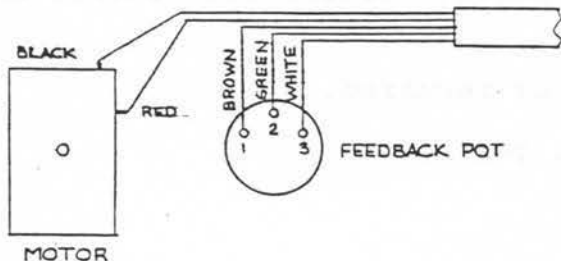

1. Loosen 5 screws securing outer bearing plate.
2. Cut wires and remove motor. Save old motor for return to the shop.
3. Position new motor in bracket. Use a couple of folds of gaffers tape between motor and plate as a shim to ensure tight fit.
4. Tighten screws until snug.
5. Strip wires and solder to motor as shown.
6. Grease worm gear.
7. Adjust gear mesh.

Following installation of tilt motor, reinstall tilt bracket (para. 2-57). Calibrate pan/tilt assembly when finished (para. 2-22).

2-60. PAN/TILT CLUTCH ADJUSTMENT

Open the upper enclosure to gain access to the pan bracket. Remove head covers and iris bulkhead assembly to gain access to tilt bracket. To adjust clutch, proceed as follows:

1. Loosen set screw in collar.
2. Screw collar CW (towards gear) to tighten clutch. Unscrew collar to loosen clutch.
3. Tighten set screw to secure adjustment.

2-61. PAN/TILT FEEDBACK POT

Removal

1. Loosen set screw in feedback pot gear.
2. Loosen screws securing feedback pot to bearing plate and remove pot.
3. Replace gear as required.
4. Replace pot as required:
 - a. Cut wires from old pot.
 - b. Strip wires about 1/4 inch.
 - c. Solder wires to new pot.

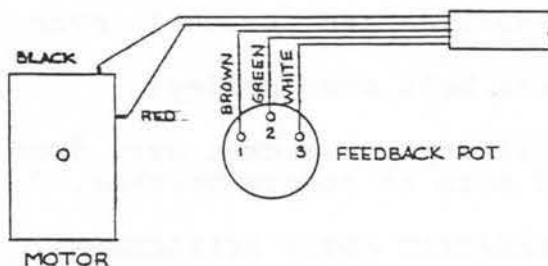

Installation

1. Position feedback pot on bearing plate. Secure with screws and clamps.
2. Install tilt bracket (para. 2-57) as required.
3. Calibrate pan/tilt assembly (para. 2-22).

2-62. PULLEY REMOVAL/INSTALLATION

Tilt Pulley--Removal

1. Remove FFA (para. 2-49).
2. Loosen tilt bracket mounting screws.
3. Set head assembly in zero position and remove belt from tilt pulley.

2-62. PULLEY REMOVAL/INSTALLATION (CONT'D)

Tilt Pulley--Removal (cont'd)

4. Using hex wrench, remove screw from the center of the pulley.
5. Remove pulley. If adhesive has been used to secure pulley, you may have to hammer it out.

Tilt Pulley--Installation

1. Position pulley in bearing.
2. Using hex wrench, secure pulley with screw.
3. Apply power to luminaire (without data) to zero the tilt motor.
4. Set head assembly in zero position and reinstall belt over tilt pulley.
5. Turn head assembly 90 degrees and tighten tilt bracket mounting screws.
6. Reinstall FFA (para. 2-49).
7. Calibrate tilt assembly (para. 2-22).

Pan Pulley--Removal

1. Loosen pan bracket mounting screws.
2. Set yoke in zero position and remove belt from pan pulley.
3. Using hex wrench, remove screw from the center of the pulley.
4. Remove pulley. If adhesive has been used to secure pulley, you may have to hammer it out.

Pan Pulley--Installation

1. Position pulley in bearing.
2. Using hex wrench, secure pulley with screw.
3. Apply power to luminaire (without data) to zero the tilt motor.
4. Set yoke in zero position and reinstall belt over pan pulley.
5. Tighten pan bracket mounting screws.
6. Calibrate pan assembly (para. 2-22).

2-63. BELT REPLACEMENT

To replace tilt belt, first remove tilt bracket from head assembly (para. 2-57) and proceed. To replace pan belt, proceed as follows:

1. Remove 5 screws securing outer bearing plate.
2. Carefully separate plate from bracket assembly. Keep bearings together with motor/sprocket shafts. Carefully disengage feedback pot gear from sprocket.
3. Remove belt.
4. Install new belt around sprocket.
5. Fit outer bearing plate on bracket assembly. Ensure bearings are seated squarely in mounting holes. Carefully engage feedback pot gear to sprocket.
6. Secure plate with 5 screws.
7. Install tilt bracket as required (para. 2-57).
8. Fit belt over pulley and tighten bracket mounting screws.
9. Calibrate pan/tilt (para. 2-22).

Section X. YOKE AND YOKE CABLE

<u>Paragraph</u>	<u>Page</u>	<u>Paragraph</u>	<u>Page</u>
2-64. YOKE REMOVAL.....	2-65	2-66. YOKE CABLE REMOVAL.....	2-67
2-65. YOKE INSTALLATION.....	2-66	2-67. YOKE CABLE INSTALLATION.	2-68

2-64. YOKE REMOVAL

1. Remove fan from head assembly (para. 2-33).
2. Unplug IDC connectors from wheel servo board.
3. Remove 4 screws from wheel servo board. Remove wheel servo board.
4. Remove lamp (para. 2-36).
5. Remove 2 hex nuts securing each shroud cap. Remove both shroud caps.
6. Remove 2 screws securing each heat baffle. Remove 2 heat baffles.
7. Remove 4 screws securing FFA. Remove FFA.
8. Remove side shrouds.
9. Remove yoke cable (para. 2-66).
10. Using No.1 Phillips screwdriver, remove 2 screws and nuts securing heat shield behind tilt pulley. Remove heat shield.
11. Using No.2 Phillips screwdriver, remove 2 screws from front bulkhead and 2 screws from rear bulkhead. Remove the side rail with the tilt stop mounted to it.
12. Turn head assembly to the zero position. Loosen tilt bracket mounting screws. Remove belt from tilt pulley.
13. Using allen wrench, remove retaining screw from center of tilt pulley. Remove tilt pulley. If adhesive has been used to secure tilt pulley, you may have to hammer it out.
14. Remove head assembly from yoke.
15. Loosen pan bracket mounting screws. Remove belt from pan pulley.
16. Using allen wrench, remove retaining screw from center of pan pulley. Remove pan pulley.

2-64. YOKE REMOVAL (CONT'D)

17. Loosen set screw and remove yoke retaining collar.
18. Remove yoke from pan bracket bearings.

2-65. YOKE INSTALLATION

1. Fit down tube on new yoke through bearings in pan bracket.
2. Fit yoke retainer on the end of the down tube. Tighten set screw to secure retainer.
3. Fit pan pulley in the end of the yoke tube. Tap pulley into tube to align with sprocket in pan bracket.
4. Secure pulley with allen screw.
5. Slide drive belt out of the way.
6. Install 3 ty-wrap saddles in new yoke. Secure with 1 screw and nut in each saddle.
7. Fit new ty-wraps through saddles.
8. Install side rail/end bulkhead assembly on yoke side tube. The side rail with the tilt bracket mounted to it goes on the yoke side tube on the same side as the pan stop mounts, and opposite where the ty-wrap saddles mount.
9. Fit tilt pulley in side tube. Tap pulley in tube to align with sprocket in tilt bracket.
10. Secure pulley with allen screw. Tighten screw until flush with outer surface of pulley hub.
11. Apply power to luminaire (without data) to zero the tilt motor.
12. Turn head to zero position (window pointing straight up away from UPE) and fit belt over tilt pulley.
13. Turn head assembly 90 degrees and tighten tilt bracket mounting screws.
14. Fit ty-wrap through saddle on the other side rail.
15. Install side rail on the other side tube. Secure to end bulkheads with 2 screws in each bulkhead. Flex side rails as required to align screw holes.
16. Install yoke cables (para. 2-67).

2-65. YOKE INSTALLATION (CONT'D)

CAUTION

Keep all wires out of the path of the light beam or the wires will melt.

16. Position heat shield on side rail behind tilt pulley. Secure heat shield with 2 screws and nuts.
17. Fit side shrouds over bearings on side rails.
18. Slide FFA into notches cut in side rails. Secure with 4 screws.
19. Position heat baffles on side rails. Secure upper baffle with 2 screws. Secure lower baffle and ground wire with 2 screws.
20. Install thermal fuse (para. 2-39).
21. Crimp lug to ground wire (green/white twisted with wire braid). Secure ground lug to heat baffle.
22. Fit shroud caps over wheels with louvers opening to the rear. Secure shroud caps with 2 nuts on each cap.
23. Install lamp (para. 2-36).
24. Position wheel servo board on standoffs with tall heat sinks forward. Secure with 4 screws.
25. Plug-in IDC connectors to wheel servo board as follows:
 - P1 : 6-pin control signal input.
 - P2 : 3-pin +/-20 volts input.
 - P3 : 5-pin wheel 1 connector.
 - P4 : 5-pin wheel 2 connector.
 - P5 : 5-pin wheel 3 connector.
 - P6 : 5-pin wheel 4 connector.
 - P7 : 5-pin tilt assy connector.
 - P8 : 5-pin iris assy connector.
 - P9 : 5-pin +/-15 and +/-12 volts input.
26. Reinstall fan (para. 2-33).

2-66. YOKE CABLE REMOVAL

To prepare for yoke cable removal, refer to paragraph 2-64. Yoke Removal, steps 1 thru 8.

To remove the multi-core cable, proceed as follows:

1. Unplug IDC connectors from servo power supply P1 and P2, and from receiver board P7.

2-66. YOKE CABLE REMOVAL (CONT'D)

2. Remove hex nut securing cable clamp to UPE chassis ground screw. Remove clamp.
3. Loosen hex nut securing ground wire to UPE chassis ground screw. Disconnect ground wire.
4. Remove IDC connectors from head assembly end of multi-core cable.
5. Unplug fan power connectors at head end and at UPE end. Remove pins from both connectors.
6. Cut ty-wraps on pan bracket (1), yoke (3), service loop (1), and head assembly side rail (1).
7. Uncoil cable from around yoke down tube (inside pan bracket).
8. Pull yoke cable through down tube from UPE end.

2-67. YOKE CABLE INSTALLATION

Installation--Head Assembly

1. Obtain 9 feet of multi-core yoke cable. Insert one end of yoke cable into head assembly through rubber bushing in side of yoke.
2. Strip jacket from head end of cable. Measure from back corner of head assembly to iris bulkhead mounting notch. Strip this length of outer jacket.
3. Remove exposed length of foil shield.
4. Slide about 6 inches of heat-shrink sleeving over cable. Separate the red/green wire and the black wire from the bundle and wrap these up. Loop these spare wires so you can pull them out later without cutting the heat shrink. Stuff these down the sleeving. Heat-shrink to secure spare wires.
5. Separate the green/white wire and the wire braid from the bundle. Twist these two together. Crimp a lug on the end.
6. Separate the red/blue wire from the bundle and twist it with the green/white and braid.
7. Separate the following wires from the bundle and twist them together: red, green, blue.

2-67. YOKE CABLE INSTALLATION (CONT'D)

Installation--Head Assembly (cont'd)

8. Separate the following wires from the bundle and twist them together:
 - White/red
 - White
 - Green/black
 - Orange
 - Orange/red
9. Separate the following wires and twist them together:
 - Red/white
 - Blue/black
 - Blue/white
 - Red/black
 - Orange/black
 - White/black
10. Twist the remaining wires together: black and black/white.
 - a. Strip the wires about 1/4 inch. Crimp connector pins to the wires.
 - b. Insert pins in pins 1 and 3 of a 3-pin connector shell.
11. If you are installing new lamp wires as well as multi-core cable, proceed as follows. Otherwise, skip to step 12.
 - a. Obtain 6 feet of lamp wires; one red, one black.
 - b. Strip wires about 1/4 inch and crimp connector pins on lamp wires.
 - c. Insert lamp wires into head assembly, through the rubber bushing, under the multi-core cable.
 - d. Slip a 3-inch piece of heat-shrink sleeving over the end of the lamp wires. Position the sleeving 2 inches from the connector pins and shrink in place.
 - e. Insert pins in 3-pin connector shell; black in pin 1, red in pin 3.
12. Secure lamp wires and multi-core cable to side rail as follows:
 - a. Measure length of lamp wires. Hold connector shell up to front bulkhead and run wires back to about 1 inch behind side bearing.
 - b. Lay the multi-core cable next to the lamp wires so the two pieces of heat-shrink lie next to each other.
 - c. Tighten the ty-wrap around the heat-shrink portion to secure both cable assemblies.
13. Install a 3-pin IDC on the 3-wire bundle. Gather up wire bundle and cut off ends even with each other. Insert wires in connector as follows:

Pin 1: Red

Pin 2: Green

Pin 3: Blue

2-67. YOKE CABLE INSTALLATION (CONT'D)

Installation--Head Assembly (cont'd)

14. Install a 5-pin IDC on the 5-wire bundle. Gather up wire bundle and cut off ends even with each other. Insert wires in connector as follows:

Pin 1: Orange/red	Pin 4: White
Pin 2: Orange	Pin 5: White/red
Pin 3: Green/black	

15. Install a 6-pin IDC on the 6-wire bundle. Gather up wire bundle and cut off ends even with each other. Insert wires in connector as follows:

Pin 1: Orange/black	Pin 4: Blue/white
Pin 2: Blue/black	Pin 5: Red/black
Pin 3: Red/white	Pin 6: White/black

Installation--Yoke Down Tube

16. Thread multi-core cable and lamp wires down the inside of the yoke as shown.

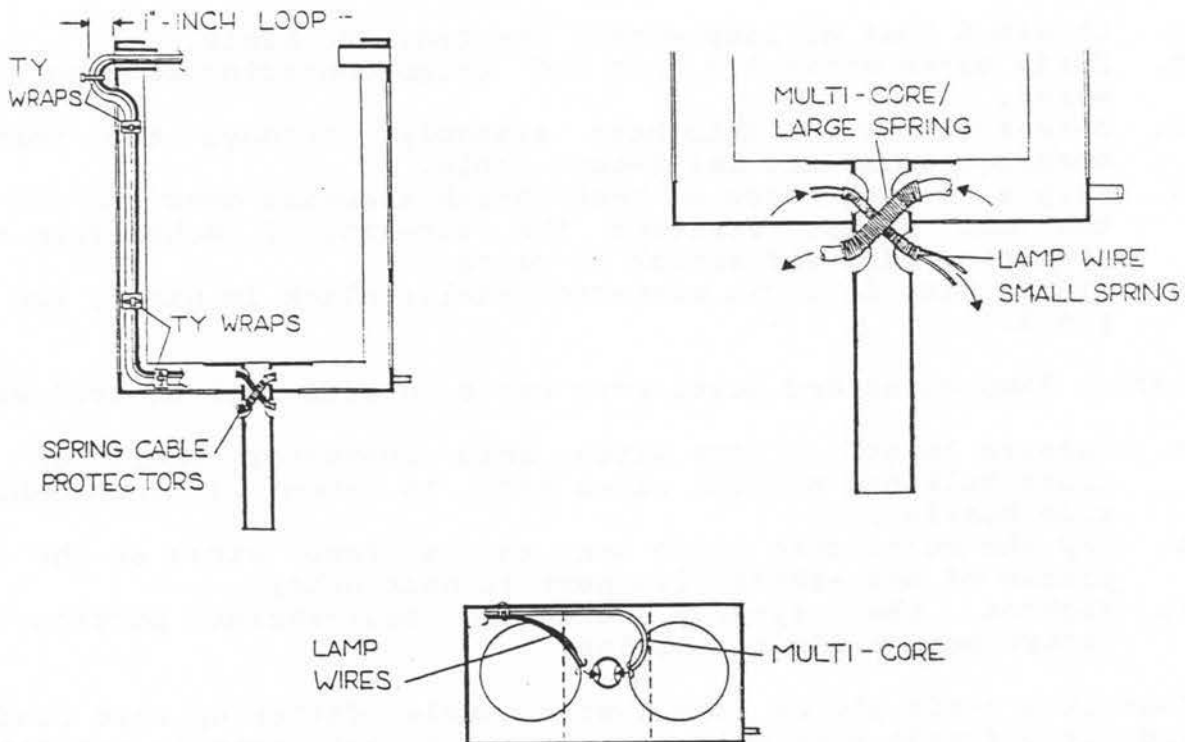

17. Leave a 1-inch loop at the end of the yoke near the rubber bushing. Secure cables to yoke with 3 ty-wraps.

2-67. YOKE CABLE INSTALLATION (CONT'D)

18. Ty-wrap the lamp wires and multi-core cable together in the middle of the 1-inch loop.
19. Loop the multi-core cable around the large opening in the far side of the yoke base. Fit spring protector over end of cable. Insert cable in down tube and out the opposite side as shown. Position spring so it protects the cable through the down tube. Work the cable through the down tube carefully so as not to rip the outer jacket.

Installation--Upper Enclosure

Ensure drive belt has been removed from pan pulley, and pan stop has been removed from yoke.

20. Fit the spring in the down tube on the near side and out the far side as shown. Thread the lamp wires through the spring. Leave a little slack in the lamp wires but no loop is required.
21. Rotate yoke 8 complete turns to wrap cables around down tube. Pull multi-core cable fairly tight.
22. Back-off 2 complete turns to loosen multi-core cable.
23. Apply power to luminaire (without data) to zero the tilt motor.
24. Set yoke in zero position and reinstall belt over pan pulley.
25. Uncoil lamp wires and disentangle from multi-core cable.
26. Install pan stop on yoke and secure with 1 screw and nut.
27. Twist lamp wires together.
28. Rotate yoke until pan stops touch. Leave a little slack in lamp wires and secure lamp wires to pan bracket with ty-wrap.
29. Rotate yoke back-and-forth to check slack in lamp wires.
30. Pull lamp wires out over lamp power supply and cut the wires about over the center of the LPS.
31. Strip lamp wires about 1/4 inch. Crimp pins to wires. Insert pins in connector shell; black in pin 1, red in pin 3.
32. Strip jacket from UPE end of cable. Lay the cable along the inside of the enclosure next to the hinge. Measure from the corner back to the chassis ground screw. Strip this length of outer jacket.
33. Remove exposed length of foil shield.

2-67. YOKE CABLE INSTALLATION (CONT'D)

Installation--Upper Enclosure (cont'd)

34. Slide about 6 inches of heat-shrink sleeving over cable. Separate the red/green wire and the black wire from the bundle and wrap these up. Loop these spare wires so you can pull them out later without cutting the heat shrink. Stuff these down the sleeving. Heat-shrink to secure spare wires.
35. Separate the red, green, and blue wires from the bundle and twist them together.
 - a. Gather up the 3-wire bundle and cut off ends even with each other.
 - b. Insert wires in 3-pin IDC connector as follows: Pin 1: Blue
Pin 2: Green Pin 3: Red
36. Separate the following wires from the bundle and twist them together:
 - White/red
 - White
 - Green/black
 - Orange
 - Orange/red
37. Install a 5-pin IDC on the 5-wire bundle. Gather up wire bundle and cut off ends even with each other. Insert wires in connector as follows:

Pin 1: White/red	Pin 4: Orange
Pin 2: White	Pin 5: Orange/red
Pin 3: Green/black	
38. Separate the following wires and twist them together:
 - Red/white
 - Blue/black
 - Blue/white
 - Red/black
 - Orange/black
 - White/black
39. Install a 6-pin IDC on the 6-wire bundle. Gather up wire bundle and cut off ends even with each other. Insert wires in connector as follows:

Pin 1: Red/white	Pin 4: Red/black
Pin 2: Blue/black	Pin 5: Orange/black
Pin 3: Blue/white	Pin 6: White/black
40. Separate the green/white wire and the wire braid. Twist these together.
 - a. Strip the green/white wire about 1/4 inch.
 - b. Twist the ends together and crimp a spade lug to them.
 - c. Secure the lug to the UPE chassis ground screw with a hex nut.

2-67. YOKE CABLE INSTALLATION (CONT'D)

Installation--Upper Enclosure (cont'd)

41. Twist the remaining wires together: blue/red, black, and black/white.
 - a. Strip the wires about 1/4 inch. Crimp connector pins to the wires.
 - b. Insert pins in a 3-pin connector shell as follows: Pin 1: Black Pin 2: Blue/red Pin 3: Black/white
 - c. Plug connector to fan power connector.
42. Secure multi-core cable assembly to chassis ground screw with cable clamp and hex nut.
43. Plug IDC connectors to circuit card connectors as follows:
 - o 3-pin IDC to servo power supply P1.
 - o 5-pin IDC to servo power supply P2.
 - o 6-pin IDC to receiver board P7.

Installation--Finishing-up

If you are in the middle of installing a new yoke, or if you are simply replacing yoke cables, refer to paragraph 2-65. Yoke Installation and proceed with step 16.

UPPER ENCLOSURE			WIRING DIAGRAM--YOKE CABLE ASSY		
PIN	WIRE COLOR	FUNCTION	PIN	WIRE COLOR	FUNCTION
<u>Receiver P7</u>			<u>Servo Board P1</u>		
1	red/wht	IRIS	1	org/blk	WH2 (Wh2)
2	blu/blk	BEAM (Wh4)	2	blu/blk	BEAM (Wh4)
3	blu/wht	TILT	3	red/wht	IRIS
4	red/blk	WH1 (Wh3)	4	blu/wht	TILT
5	org/blk	WH2 (Wh2)	5	red/blk	WH1 (Wh3)
6	wht/blk(gry)	WH4 (Wh1)	6	wht/blk(gry)	WH4 (Wh1)
<u>Servo Power Supply P1</u>			<u>Servo Board P2</u>		
1	blu	-20V	1	red	+20V
2	grn	GND	2	grn	GND
3	red	+20V	3	blu	-20V
<u>Servo Power Supply P7</u>			<u>Servo Board P9</u>		
1	wht/red(yel)	-15V	1	org/red(yel/blk)	+15V
2	wht	-12V	2	org	+12V
3	grn/blk	GND	3	grn/blk	GND
4	org	+12V	4	wht	-12V
5	org/red(yel/blk)	+15V	5	wht/red(yel)	-15V
<u>Fan Power Connector</u>			<u>Fan Power Connector</u>		
1	blk	AC Hot	1	blk	AC Hot
2	blu/red(vio)	ThermalFuse	2	no connection	
3	blk/wht	AC Neutral	3	blk/wht	AC Neutral
<u>Chassis Ground</u>			<u>Chassis Ground</u>		
LUG	grn/wht	GND	LUG	grn/wht	GND
LUG	wire braid	GND	LUG	wire braid	GND
<u>Solid State Relay</u>			<u>Thermal Fuse</u>		
	blu/red(vio)	SSR GND		blu/red(vio)	SSR GND
<u>Spare Wires</u>					
	red/grn(yel/wht)			blk/red(brn)	
	(brn/wht)			(org/wht)	
	(gry/wht)			(vio/wht)	
	(vio/blk)				

NOTE: Wire colors in parentheses refer to new 25-conductor yoke cable. Functions in parentheses refer to true function as opposed to the way the receiver board P7 is labelled on the board.

Section XI. PREPARATION FOR STORAGE OR SHIPMENT

2-68. TRAVEL CASES

Packing

To minimize damage during shipment, VARI*LITE luminaires should be packed as follows:

1. Set the yoke in the zero pan position.
2. Set the head assembly parallel to the upper enclosure (UPE) with the head fan facing the UPE.
3. Set the luminaire in the travel case head down.
4. Remove the mounting brackets from their sockets and store on top of the UPE.
5. When the travel case is full, or when all luminaires are packed, set the lid on the case and secure latches.

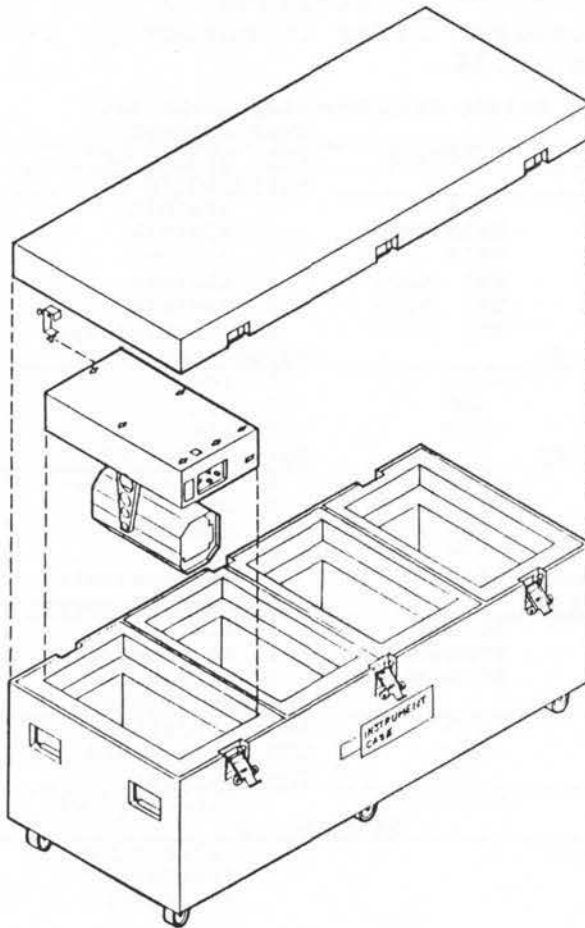

VARI*LITE
02-3002-0002

2-68. TRAVEL CASES (CONT'D)

Unpacking

To minimize effort, the travel cases should be rolled on-stage to the approximate mounting location before unpacking the luminaires.

1. Unlatch and remove lids.
2. Install mounting brackets in the appropriate sockets.
3. Grasp brackets and remove luminaire from case.
4. Mount luminaire to truss. Refer to paragraph 2-4. Mounting Requirements.

2-69. SHIPPING DATA

ITEM	DESCRIPTION	LENGTH (in.)	WIDTH (in.)	HEIGHT (in.)	WEIGHT (lb.)	DECLARED VALUE(\$)
1	5-Hole Case w/VL1s	89	30-1/2	30	500	7500.00
2	4-Hole Case w/VL1s	72	30-1/2	30	425	6000.00
3	2-Hole Case w/VL1s	38	30-1/2	30	245	3000.00
4	Console	56	24	48	425	5000.00
5	Control Rack	27	22	44	200	7500.00
6	ACS Rack	27	22-1/2	30	150	1000.00
7	Work Trunks	39-1/2	24-1/2	30	500	750.00
8	Test Rack	22-1/2	27	53	275	1000.00
9	Transformer	22-1/2	27	53	500	300.00
10	Monitor (Lg)	15-1/2	15-1/2	14-1/2	25	100.00

VARI*LITE
02-3002-0002

(THIS PAGE BLANK)

CHAPTER 3

TECHNICAL MAINTENANCE INFORMATION

Section I. THEORY OF OPERATION

3-1. VARIABLE LIGHTING INSTRUMENT

By now you should be familiar with the mechanics of the VARI*LITE 1 (VL1) luminaire, and know how to calibrate and repair the various sub-assemblies. In this chapter we will describe some of the more arcane workings of the luminaire, primarily for the benefit of the electronics technician who may be called upon to repair electronic circuits not covered in chapter two.

So how does the console and control rack communicate with the VL1 luminaires? You know that each luminaire can be set to respond to one of 100 channels, and that the control rack sends commands over 96 of those channels. The control rack sends a signal over a two-conductor shielded pair. This is a balanced line signal in which the signal that appears on one wire is inverted on the other wire. Throughout the following discussion we will describe the Positive Data signal, keeping in mind the same things are happening in the Negative Data signal, but the polarity of the signal is reversed.

NOTE

Refer to paragraph 3-11. Trouble With The Repeater for a discussion of how the control signal is transmitted through the repeater.

3-2. CONTROL SIGNAL

The control signal is generated by the control rack and transmitted to the VL1 luminaires via the ACS Rack, repeater, and associated cables. The control rack transmits 96 frames of address and data, one frame for each channel, approximately 18 times each second. Each frame corresponds to one channel or address, and contains all the data necessary to specify intensity, lamp on/off, pan/tilt position, color and beam size for a given luminaire.

3-2. CONTROL SIGNAL (CONT'D)

Each frame begins with a 10 micro-second (10 uS) sync pulse. Eight bits of address follow the sync pulse. Forty-eight (48) data bits follow the address information. Each bit is 10 uS wide. Each frame is about 580 uS wide, and is organized as follows:

- SYNC PULSE. A negative-going pulse 15 volts in amplitude, 10 uS wide.
- ADDRESS. Eight bits of information, organized as two Binary-Coded Decimal (BCD) digits. The first four bits are the Most Significant Digit (MSD). The second four bits are the Least Significant Digit (LSD). The first bit is the Most Significant Bit (MSB). The last bit is the Least Significant Bit (LSB). The BCD digits correspond to the two-digit thumbwheel address set on the luminaire.
- INTENSITY. Eight bits of data: two BCD digits; MSB first, LSB second. A 10 uS space separates the address and intensity data.
- LPS CONTROL. Four bits of data: LAMP ON, START-, CHASE OFF (not used), and FLASH (not used). Followed by four bits that are not used.
- PAN DATA. Eight bits: two BCD digits (MSD, LSD).
- TILT DATA. Eight bits: two BCD digits (MSD, LSD).

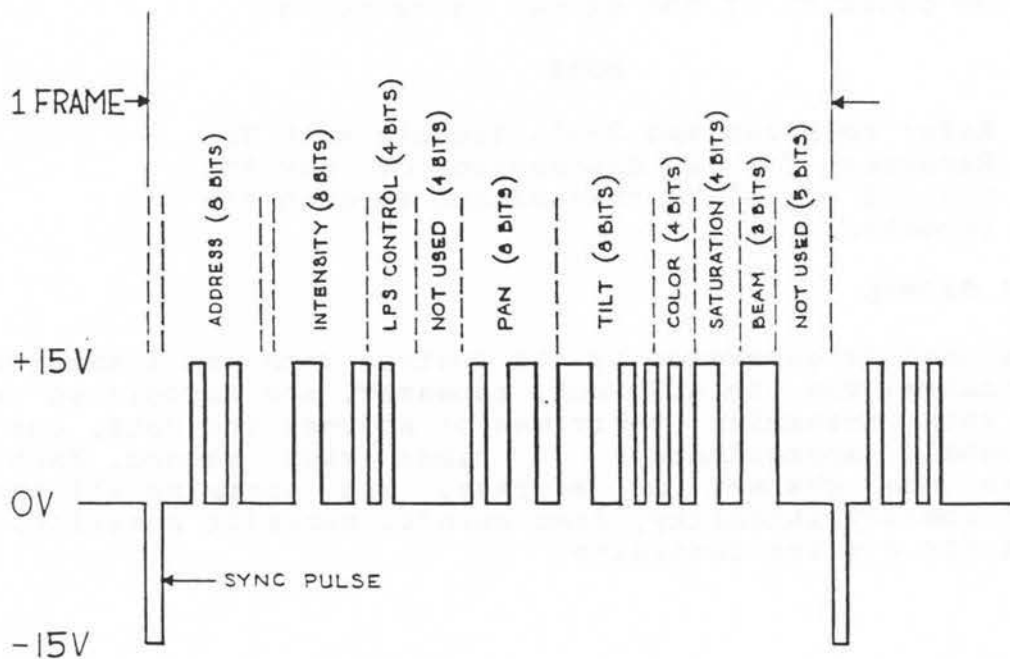

3-2. CONTROL SIGNAL (CONT'D)

- COLOR/SATURATION DATA. Four bits Color; four bits Saturation.
- BEAM SIZE DATA. Three bits of data followed by five bits not used.

The control rack transmits frames of data continuously. When you go to a new cue, the data is updated and transmitted. The control rack does not transmit the necessary data and then stop. The entire group of 96 frames takes about 55 milli-seconds (55 mS) to transmit. The lites receive sync pulses every 580 uS. If the sync pulses are not received, the lite closes its iris, but otherwise remains the same.

3-3. DATA RECEIVER

The operation of the Data Receiver circuit card assembly is best understood by considering three aspects of its internal functions: timing, data handling, and data conversion. The timing function breaks the frame into 580 parts, each 1 uS long. The data handling function screens the incoming sync, address, and data signals to eliminate noise or false data, and routes good data to the appropriate place. The data conversion function translates incoming data to control signals required by the servo circuits and Lamp Power Supply control circuit.

Timing

The frame is composed of 58 bit fields, each 10 uS wide. The first is the sync pulse field (bit field 00), followed by 8 fields of address bits, one blank field (bit field 09) separating the address from the data, and 48 fields for data bits. When a sync pulse appears at the Data/Sync Separator, the Sync Qualifier counts off 10 intervals of 1 uS each and, if the sync pulse is present for all 10 intervals, a Frame Enable signal (FRMEN-) is asserted. This enables the Clock Timing Counter and Data Bit Counter. The Clock Timing Counter counts off 10 intervals of 1 uS each during each of the remaining 57 bit fields. Several things happen sequentially during each of the 57 bit fields:

1. LATCH CLOCK (LCHCK). Asserted during interval 1, this signal clocks the Data Latches and combines with the data bit count to clock the Address Comparator's output flip-flop.
2. INTERNAL CLOCK (INTCK). Asserted during interval 2, this signal clocks the Data Bit Counter to increment the data bit count. By counting the data bits as they come in, the Receiver then "knows" whether the bit is address, Intensity data, Color data, Tilt data, or whatever.

3-3. DATA RECEIVER (CONT'D)

Timing (cont'd)

3. CLOCK RESET CLOCK (CRSCK). Asserted during interval 3, this signal combines with Frame End (FREND) to reset the Data Bit Counter. FREND is only asserted when the data bit count equals 57. So during interval 3 of bit field 57, the data bit count is reset to 0 to await the first address bit of the next frame.
4. SAMPLE A CLOCK (SMACK). Asserted during interval 4, this signal clocks a D flip-flop to load the first of five samples of the incoming data bit into the Data Sampling logic.
5. SAMPLE B CLOCK (SMBCK) -- SAMPLE E CLOCK (SMECK). Asserted during intervals 5 thru 8 respectively, these signals clock four other D flip-flops to load four more samples of the incoming data bit into the Data Sampling Logic.
6. SHIFT REGISTER CLOCK (SHRCK). Asserted during interval 9, this signal clocks the Data Shift Register to load the output of the Data Sampling Logic into the register.

At the end of the ten intervals (0 thru 9), several things have been accomplished: the Data Bit Counter has been incremented so we know which bit this is; five samples of the data bit have been loaded and compared by the majority logic gate; and the resultant data bit has been shifted into the Data Shift Register and thereby placed on the internal data bus. During interval 0 of the next bit field, the new data bit appears at the Data Sampling Logic flip-flops, and the process starts over.

Data Handling

Within each frame, the Data Bit Counter determines what will be done with the data bits as they are received. During the first 4 uS for each bit field, clock signals increment counters and the resultant control signals configure the Address Comparator or Data Latches to receive data bytes from the Data Shift Register. During the next 5 uS, the Data Sampling Logic loads samples of the data bit to determine if the bit is HI or LO. In the final micro-second, the data bit is loaded into the Data Shift Register.

3-3. DATA RECEIVER (CONT'D)

Data Handling (cont'd)

When the last bit of an 8-bit byte has been shifted into the Data Shift Register, the data is then utilized during the first few microseconds of the next bit field. If address bits are in the Data Shift Register, the Data Bit Counter asserts Address Clock (ADRCK) to load the results of the comparison into a flip-flop. An entire 10 uS bit field is reserved as a blank to provide enough time for address processing to occur. If data bits are in the Data Shift Register, the necessary data latching is accomplished in the first 4 uS of the next bit field. The data processing is then completed before samples of the subsequent bit (MSB of the next byte) are taken.

Data Conversion

Digital-to analog converters with operational amplifier current-to-voltage converting output buffers are used to translate data bytes to control voltages. The converters circuits are configured differently to accomodate differing requirements.

The Intensity circuit converts an 8-bit byte to a 0-to-12 volt signal, where zero data equals zero volts. The Pan circuit converts an 8-bit byte to a +/-8 volt signal. The MSB is inverted prior to conversion so that zero data yields zero volts, and that corresponds to mid-position at the Pan mechanism. The Tilt circuit is configured similarly to the Pan circuit, except that the output is scaled down to +/-6 volts.

The Beam circuit only requires the three Most Significant Bits of the beam size byte to specify one of eight positions of the beam wheel. The Beam control voltage goes from 0-to-12 volts in seven steps. The color circuit converts an 8-bit byte to three control signals of 0-to-12 volts, and utilizes three PROMs to relate color data to filter wheel positions. Each PROM yields a 3-bit output and from this point on the circuits are identical to the beam circuit.

Circuit Diagram - Functional Groups

The schematic diagram for the Data Receiver is divided into functional groups. Refer to the diagram on pages 3-33 and 3-35 during the following discussion.

- MASTER CLOCK OSCILLATOR. Three gates of U7 and the 4 MHz crystal comprise the signal source for on-board timing circuits. The 4MHz output, CLK4M, is used to drive the divide-by-four and decade counters in the Sync Qualifier and Clock Timing Counter circuits.
- DATA/SYNC ISOLATOR/SEPARATOR. U1, a dual optical isolator, performs as a balanced line receiver and data/sync separator. One side of the isolator responds to data bits and generates the data input signal DTINP. The other side responds to sync pulses and generates the sync input signal SNCIN.

3-3. DATA RECEIVER (CONT'D)

Circuit Diagram - Functional Groups (cont'd)

- SYNC QUALIFIER. The SCNIN signal appears at the data input of D-type flip-flop U9 (U9-5). The same signal inverted, SCNIN-, holds counters U3A and U4 in reset until a sync pulse appears on the balanced line input. When the sync pulse appears, the counters are driven by the 4MHz Master Clock Oscillator. If the sync pulse remains present for 10 uS, the SCNIN signal is clocked into the D flip-flop and a Frame Enable (FRMEN-) signal is asserted. If the sync pulse is not present the required 10 uS, the counters are reset and the flip-flop is not clocked.
- CLOCK TIMING COUNTER. When the FRMEN- signal is asserted, counter U3B divides the output of the Master Clock Oscillator down to 1 MHz. This drives decade counter U8, which is used to generate a variety of clocking signals. These include a Latch Clock (LCHCK), Internal Clock (INTCK), Clock Reset Clock (CRSCK), data Sample Clocks (SMACK, SMBCK, SMCK, SMDCK, SMECK), and Shift Register Clock (SHRCK).
- DATA SAMPLING LOGIC. The DTINP signal appears at the data inputs of five D flip-flops: U9B, U12, and U13. The Clock Timing Counter generates five clock signals, Sample A Clock (SMACK) thru Sample E Clock (SMECK), 1 uS apart. This loads five samples of DTINP into the five flip-flops in 5 uS. Majority logic gate U18 determines from 3-of-5 samples whether the data is HI or LO. The output, DXMAJ, is applied to the Data Shift Register.
- DATA BIT COUNTER. Decade counters U5 and U20 are driven by the Internal Clock (INTCK) output of the Clock Timing Counter. This circuit counts data bits and, through a group of logic gates, generates Internal Data control signals INTD1- thru INTD6- used to latch data bits into the appropriate Data Latches. The circuit also generates Frame End (FREND) and Frame Reset (FRMRS) signals.
- POWER-ON RESET. R19, C3, and two Schmidt-trigger gates of U6 reset the Data Latches to zero when the power is first applied.
- ADDRESS COMPARATOR. U15 and U16 compare DBUS0 thru DBUS7 to the 2-digit thumbwheel switches. When the Data Bit Counter counts up to 09, all eight address bits will be present on the internal data bus, DBUS0 thru DBUS7. During this time, in the 10 uS space between the address bits and the Intensity data bits, an Address Clock (ADRCK) signal clocks the results of the address comparison into a D flip-flop, U11A. The output of U11A is a Latch Enable (LCHEN-), which will remain set (LO) or reset (HI) until the end of the current frame. If the address comparison is good, the Data Latches are now enabled to store incoming lamp data bits. If the comparison is not good, no new data will be latched.

3-3. DATA RECEIVER (CONT'D)

Circuit Diagram - Functional Groups (cont'd)

- DATA SHIFT REGISTER. The Shift Register Clock (SFRCK) signal from the Clock Timing Counter clocks data DXMAJ into the 8-bit shift register U17. The eight outputs, DBUS0 thru DBUS7, are applied to the Address Comparator and the Data Latches.
- DATA LATCHES. Data is latched when three conditions are met. First, a valid address comparison asserts the Latch Enable (LCHEN-) signal. Second, the data bit counter asserts the appropriate Internal Data (INTD1- thru INTD6-) signal to enable the correct latch. Finally, the Latch Clock (LCHCK) signal is asserted. Internal Data signals correspond to data bytes as follows:
 - INTD1-: Intensity data.
 - INTD2-: Lamp power supply control byte.
 - INTD3-: Pan data.
 - INTD4-: Tilt data.
 - INTD5-: Color data.
 - INTD6-: Beam size data.
- DIGITAL-TO-ANALOG CONVERTERS. Once the data appears at the Data Latch outputs, Intensity, Pan, Tilt, and Beam size data is immediately converted to analog control voltages by DAC-08 digital-to-analog converters U38, U37, U43, and U44 respectively. Color data is used to address three PROMs, (U36, U35, and U34) which contain the appropriate 3-bit codes that relate Color data to filter wheel positions. Converters U40, U41, and U42 convert the PROM outputs to analog control voltages.
- LAMP ON LOGIC. The Lamp On (LMPON) signal is derived from bit field 10, the 10th data bit following the sync pulse in each frame. This bit is not latched in the Data Latches along with the other data. Rather, it is applied to the D input of shift register U39. This register is clocked once each frame when three signals are asserted: LCHEN, LCHCK, and INTD2-. The result is that the control rack must tell the VL1 luminaire three times to turn the LPS on or off before the Lamp On Logic responds. U45, a majority logic gate, reads the outputs of U39 and determines whether the LMPON signal should be set or reset.
- LAMP START. The Lamp Start (LMPST-) signal is derived from bit field 11. This bit is latched in U21 along with the Chase Off and Flash bits which are not used. Data Latch signal DLH26 is applied to inverter U27-10 and output to the LPS through Q3.

3-3. DATA RECEIVER (CONT'D)

Circuit Diagram - Functional Groups (cont'd)

- INTENSITY/LAMP STANDBY LOGIC. U31 is an 8-input NOR gate which reads all eight bits of latched Intensity data (DLH10 thru DLH19). When all eight bits are zero, the Lamp Standby (LSTBY) signal is asserted after a 1/2-second delay. The RC network associated with U6-12/-13 provides the 1/2-second delay to allow the iris to close fully before switching to standby lamp current. The same network provides for very fast switching back to normal run current when Intensity data is incremented above zero and the iris starts to open.
- SIGNAL SENSING. The received sync pulse (SNCIN) triggers a monostable multivibrator (one-shot, U2) with a timing period of 220 mS. If another sync pulse is not received within that timing period, the data stream is assumed to be lost and the Signal Present (SGPRS) signal is reset. This causes the Intensity data latches to be reset to zero so the iris will close. In this way, loss of data signal to any one, several, or all luminaires causes the affected lites to close their iris(es). This prevents uncontrollable luminaires from interfering with the rest of the lighting set-up until the proper data transfer can be restored.

3-4. SERVO CIRCUITS

The motors are driven by the servo circuits, which apply +20 volts or -20 volts to drive the motor in one direction or the other. The motor-driven gears operate the mechanical assemblies and rotate the position feedback pot. When the mechanical assembly reaches the desired position, the feedback voltage from the pot balances the control voltage at the servo amp input. This shuts off power to the motor.

Amplifier A1 is a dc voltage follower with ac gain. Trimpot TR3 (DAMP) controls the gain. As the gain is increased, so the speed with which the circuit responds to any change in position is also increased. If the gain is increased too much, the circuit will overshoot the desired position and then back up. If the gain is decreased too much, the circuit will undershoot the desired position and creep up.

Amplifier A2 is an inverting summing amplifier. Trimpot TR1 (SPAN) controls the gain with respect to the control voltage input. As the gain is increased, so the limit of travel of the mechanical assembly is increased. If the gain is increased too much, the circuit will exceed its limits causing pan/tilt stops to hit, iris to open too far, or FFA wheels to become misaligned or spin. If the gain is decreased too much, the circuit will not meet its limits causing the mechanical assembly to fall short of the desired position. Trimpot TR2 (ZERO) is an offset null adjustment, which provides a way to balance the control voltage and position feedback inputs when both are set to zero position.

3-4. SERVO CIRCUITS (CONT'D)

When the mechanical assembly reaches the desired position, both inputs are balanced and the output of A2 goes to zero volts. If the control voltage is changed through the receipt of new data, or if the assembly is physically displaced, the imbalance of inputs is amplified by A2. A positive voltage at the output of A2 turns on Q1, which turns on Q3, and +20 Vdc is applied to the motor through R13. A negative voltage at A2 turns on Q2, which turns on Q4, and applies -20 Vdc to the motor through R14. Resistors R13 and R14 limit the short-circuit current applied to the motor to 700mA (for wheel circuits with 1.2 ohm resistors) or 500mA (for iris and pan/tilt circuits with 1.5 ohm resistors).

3-5. LAMP POWER SUPPLIES (LPS)

The GE Marc 350 lamp requires a constant current dc power supply for operation. The power supplies used in the VL1 luminaires are pulse-width modulated, switching regulator power supplies especially designed to start and power 350 watt arc lamps. The power supplies have been modified to be compatible with the digital logic control system used in the luminaire.

The lamp and the Lamp Power Supplies (LPS) were originally designed for use in small motion picture projectors (8mm and 16mm). Some of the maintenance problems stem from the fact that the power supplies were not engineered to withstand the rigors of heavy road use. Some of the components have been secured with clear RTV to supplement the original fragile mounting technique used.

A switching power supply typically rectifies the 115 Vac input power. The resultant 165 Vdc is used to power a high-voltage driver amplifier. The amplifier used is a switching type transistor capable of very fast turn-on and turn-off times, hence the term "switching power supply." The amplifier is driven by a rectangular waveform, of variable duty-cycle, operating at 20 to 50 kilohertz. The amplifier's output is a high-frequency waveform at about 150 volts peak. Some power supplies run this through a step-down transformer, rectifier, and filter to produce a regulated dc voltage. The constant-current power supplies used in the luminaire, utilize heavy-duty inductors and electrolytic capacitors to filter the waveform down to useful and fairly steady dc.

What makes all this work is the pulse-width modulation. See the block diagram during the following discussion:

3-5. LAMP POWER SUPPLIES (CONT'D)

Functional Block Diagram

- (A) AC POWER INPUT FILTER. RF bypass capacitors and series inductors remove high frequency interference and transient voltages from the power supply.
- (B) MAIN POWER SUPPLY. Bridge rectifier and electrolytic filter capacitor(s) operate directly off the ac line through the Input Filter. No input transformer is used.
- (C) SECONDARY POWER SUPPLY. Step-down transformer with multiple secondaries is used with rectifiers and filters to produce the low voltage dc power needed to run the oscillator and control circuits. Voltages produced are typically 8 to 15 volts, and may be as high as plus-and-minus 30 volts dc.
- (D) OSCILLATOR. Free-running, 20kHz, rectangular-wave oscillator.
- (E) PULSE WIDTH MODULATOR. Feedback from the output terminals controls the pulse width applied to the Driver Amplifier. When more power is required at the output, the pulse width is lengthened. When less power is required, the pulse width is shortened. In a switching voltage regulator, the pulse width varies with the amount of output current, thereby holding the output voltage constant. In a constant current regulator such as used here, the output voltage tends to vary with the load resistance thereby holding the output current steady.

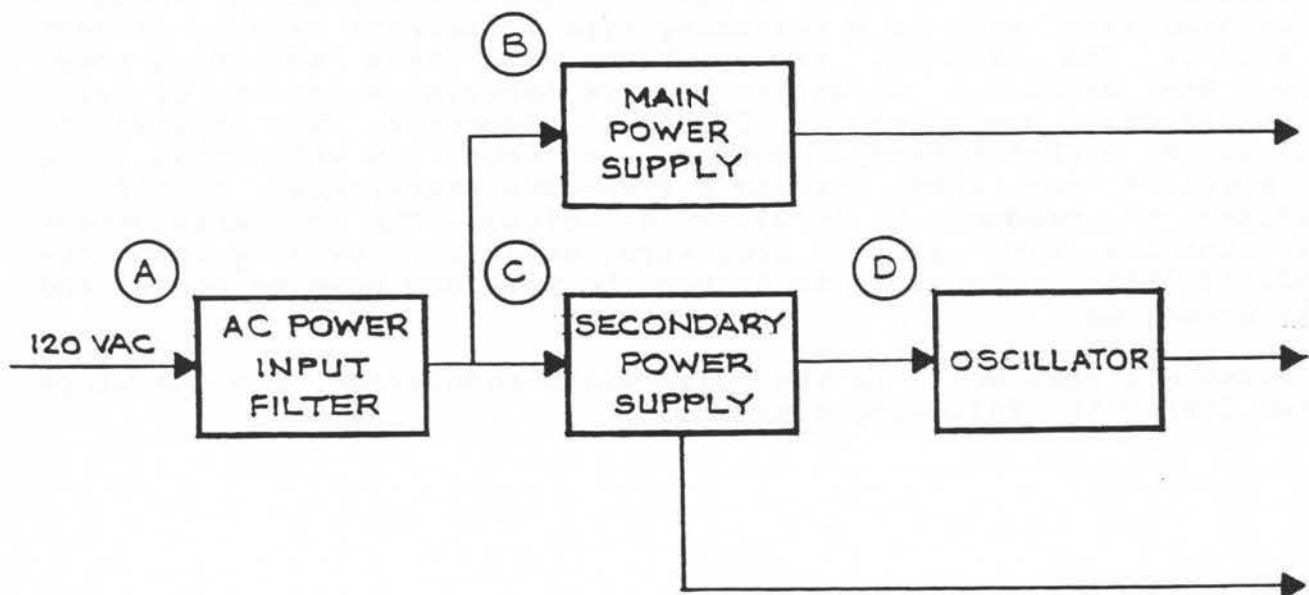

3-5. LAMP POWER SUPPLIES (CONT'D)

Functional Block Diagram (cont'd)

- (F) DRIVE AMPLIFIER. Medium power transistors amplify the output of the Modulator enough to drive the Output Driver.
- (G) OUTPUT DRIVER. High voltage, high frequency switching transistor is used here. The amplifier must respond quickly to small changes in duty cycle of a high frequency waveform. The device passes all of the load current, typically at a fairly high voltage. These units have an open circuit voltage of about 165 Vdc. Under load they supply 7.5 A into 8 ohms at 60 Vdc.
- (H) CURRENT SENSE CIRCUIT. A series resistor in the negative output circuit develops a voltage proportional to the output current. This voltage is applied to the Pulse Width Modulator as current control feedback.
- (I) START PULSE CIRCUIT. Generates a 13 kV pulse used to initiate current flow in the lamp. The high electrical potential ionizes the gas in the bulb and establishes an arc across the bulb's terminals. Once started, the bulb draws normal run current and the power supply inhibits further start pulses.

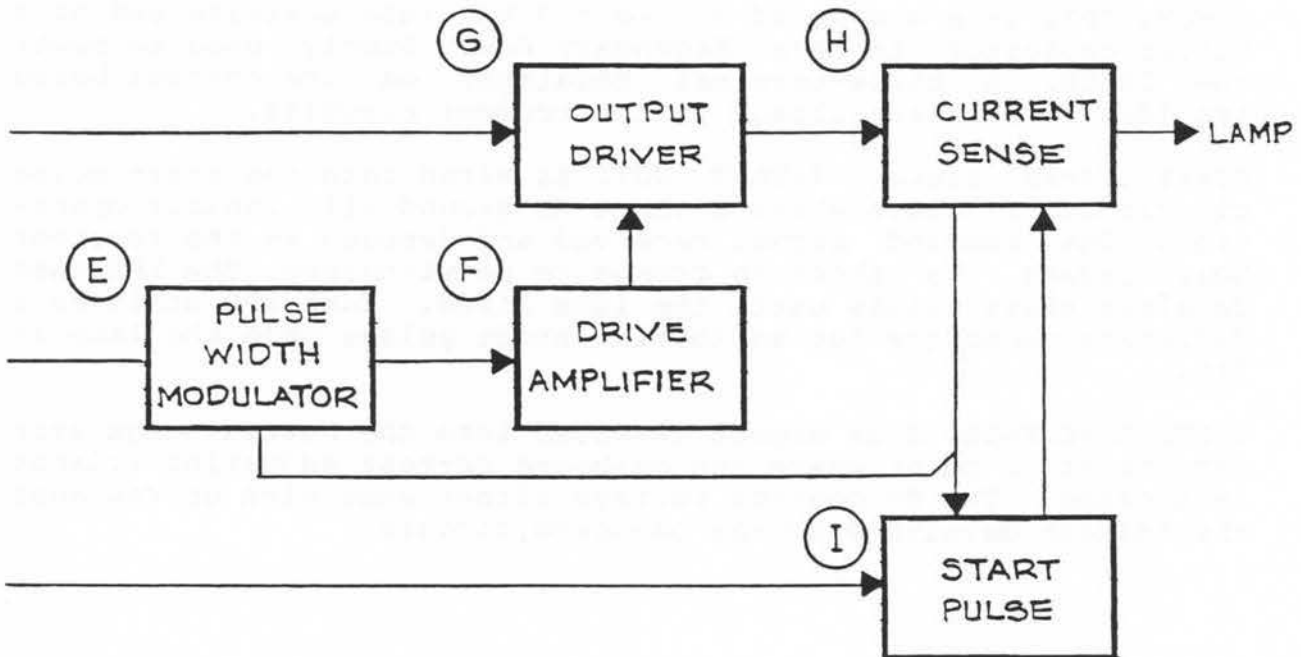

3-6. LPS CONTROLS

A solid-state relay installed on the chassis of each LPS controls ac power applied to the supply, the UPE fan, and the hour meter. When a "lamp on" (LMPON) signal is received and decoded by the receiver board, the relay is turned on. The LPS then provides 165 Vdc open circuit voltage to the lamp. When a "lamp start" (LMPST-) signal is received and decoded, the LPS generates start pulses until the lamp fires and draws current. When the LMP ON signal is reset, the solid-state relay is turned off, thereby removing power from the LPS and dousing the lamp.

While the lamp is lit, the current supplied to the lamp is controlled by one of two control voltage trimmer circuits. Normally, RUN current is set to 7.5 A by one of the trimmer circuits. When the INTENSITY data goes to zero, the receiver board develops a "lamp standby" (LSTBY) signal. LSTBY switches to a standby trimmer circuit set to limit lamp current to 4.5 A.

LPS to LPS Control Board Interface

The Lamp Power Supply Control Board (LPSCB) contains the trimmer circuits and opto-coupler devices used to implement the LSTBY and LMPST- control functions. The LMPON signal is routed through the LPSCB although no signal conditioning takes place. The LPSCB is wired directly to the LPS in four places:

- LPS GROUND. This is a floating ground about 70 volts above chassis ground. This floating ground situation requires the use of opto-couplers on the LPSCB to provide isolation between the receiver board logic circuits and the LPS control circuits.
- POWER. This is a source of +15 to +20 Vdc (the positive end of a filter capacitor in the Secondary Power Supply) used to power the LPSCB. A three-terminal regulator on the control board provides a constant voltage to the trimmer circuits.
- START-. This signal (START NOT) is wired into the start pulse circuit at a place where a short to ground will inhibit operation. The command signal received and decoded by the receiver board causes the short to ground to be withdrawn. The LPS then develops start pulses until the lamp fires. Each LPS utilizes a different technique for inhibiting start pulses once the lamp is lit.
- CONTROL VOLTAGE. This signal is wired into the current regulator circuit at a point where the on-board current adjusting trimpot is located. The dc control voltage either sums with or replaces the voltage developed by the on-board circuit.

3-6. LPS CONTROLS (CONT'D)

LPS to LPS Control Board Interface (cont'd)

The designs of the GE and EM11 lamp power supplies are similar enough in their current regulator sections that the same LPSCB can be used with either one. The design of the EM12 current regulator section is significantly different and requires a different LPSCB. However, the difference between the two types of control boards is simply the values of some of the resistors used. Otherwise the two types of control boards appear to be identical.

CAUTION

- Never operate a GE or EM11 LPS with a control card intended for an EM12 LPS. A severe overcurrent situation will develop and is likely to cause catastrophic failure of the LPS, lamp, or both.
- Also, do not attempt to operate an EM12 LPS with the wrong control board. A severe undercurrent situation will develop and may cause failure of the LPS, lamp or both.
- A GE LPS operated with no LPSCB at all will be destroyed immediately. The EM1 supplies will probably survive a power-on situation with no control board connected, but they will not operate correctly.

3-6. LPS CONTROLS (CONT'D)

LPSCB to Data Receiver Interface

The LPSCB design provides for five control signals received and decoded by the receiver board to be coupled to the LPS. Two of these signals has been disconnected at the LPSCB 5-pin IDC connector. The FLASH and CHASE OFF signals have been found to create problems resulting in failure of the LPS, in addition to the fact that their intended functions were determined to be not especially useful lighting effects. The remaining functions are essential to the operation of the VL1 luminaire.

- LAMP ON. This is a TTL logic signal which turns on the solid-state relay (SSR) when the signal is high (+5Vdc). The signal is received and decoded by the receiver board and routed thru the LPSCB with no signal conditioning of any kind; no active or passive components involved. When the signal is low, ac power is removed from the LPS and the lamp is doused.

3-6. LPS CONTROLS (CONT'D)

LPSCB to Data Receiver Interface (cont'd)

- LAMP START-. This is a TTL logic signal which inhibits LPS start pulses when the signal is high. The signal is applied to an opto-coupler input, the output of which applies an effective short to ground (or very low voltage with respect to ground) to the appropriate circuit node on the LPS. When the signal is low, the opto-coupler's output transistor is turned off, the short to ground is removed, and the LPS resumes its natural tendency to fire start pulses.
- STANDBY. This is a TTL logic signal used to switch trim pots in and out of a voltage divider circuit. When the signal is low, The RUN trimmer is connected to +5Vdc thru a small transistor. When the signal is high, two opto-couplers are turned on. One of them turns off the small transistor, thereby removing the RUN trimmer from the circuit. The other connects the STBY trimmer to +5Vdc, thereby replacing the RUN trimmer in the voltage divider circuit.
- FLASH. The function of this circuit was to increase lamp current to around 10A for about half a second. The signal was TTL logic, and operated exactly the same as STANDBY, substituting the FLASH trimmer for the RUN trimmer in the voltage divider circuit. The half-second timing was controlled by a timer circuit on the receiver board.
- CHASE OFF. The function of this circuit was to reduce lamp current with the iris open. The circuit operated exactly the same as STANDBY and FLASH.

Section II. ADVANCED TECHNICAL PROCEDURES

3-7. GE LAMP POWER SUPPLY

This unit has an oscillator and pulse-width modulator built-up around IC1 and Q1. The frequency of oscillation is adjustable by varying R12. The driver amplifier is composed of IC2, Q3 thru Q6, and Q8. The output driver, Q7, is mounted on the heat sink along with CR12, R31, and C24. The current sense network is composed of R22, a .05 ohm 5 watt wire-wound resistor, and associated RF bypass and filter capacitors.

Control Board Connections

- POWER. The red wire is soldered to the positive end of capacitor C1.
- LPS GROUND. The green wire is soldered to P2-1, pin one of a three-pin header.
- START. The brown wire is soldered to the underside of the printed circuit board where IC1-14 and Q2-base are connected.
- CONTROL VOLTAGE. The white wire is soldered to the wiper of R7, the current adjust trim pot. The trim pot may have been removed on some units. In this case the white wire is soldered to the place where the trim pot wiper should go.

3-7. GE LAMP POWER SUPPLY (CONT'D)

Common Failures

- OUTPUT DRIVER. Q7 fails taking Q3, Q5, and Q6 with it.
- DRIVER AMPLIFIER. Transistors Q3, Q5, or Q6 may fail on their own, but usually hold-up well until Q7 goes out. These devices must be removed from the circuit to use the transistor checker. False readings will result from in-circuit checks since so many of the transistor terminals are wired directly to each other.
- INTEGRATED CIRCUITS. IC1 is a quad current-differencing amplifier. IC2 is a transistor-output opto-coupler. Both are easy to replace. If the transistors are good, try replacing IC1 and/or IC2.
- START PULSE COMPONENTS. Capacitor C8 (1.0uf 400V) and diode CR9 are subjected to fairly high voltage and current bursts, and have shown a significant likelihood for failure.
- MAIN POWER FILTER CAPACITORS. Electrolytic capacitors C13, C14, and C15 are not mounted very securely and should be checked, especially if you have checked everything else and can't find the problem. With the dummy load connected, apply power to the LPS and measure the voltage across the filter caps with a DVM. If the voltage is quite low compared to the 160 Vdc open-circuit voltage, one or more of the caps may be leaky and should be replaced.
- OTHER POTENTIAL PROBLEMS. Bridge rectifier CR10 supplies all the current to the lamp. This is a heavy-duty device but is still subject to failure. Check it with the digital multimeter as described in paragraph 2-11. Transformer T1 supplies power to the Secondary Power Supply section, start pulse circuit, pulse-width modulator and driver amplifier. Check for broken wires, evidence of burning, et cetera. Also check for shorted or open rectifier diodes CR1 thru CR4, and CR15 thru CR22.

3-8. EMI1 LAMP POWER SUPPLY

The oscillator in this unit is built around Q3, a Programmable Unijunction Transistor (PUT). The pulse-width modulator is built around IC3, the 74121N monostable multivibrator (one-shot). Frequency of oscillation is adjustable at R13, a 2k ohm trim pot. Pulse width is controlled by the various inputs to IC3-11. The current regulator output at IC2-1 is coupled to IC3 thru CR11, CR10, and R18. The soft start section (Q2, CR9, and associated components) and the over-voltage protection circuit (IC2-8, CR14, and associated components) are coupled to IC2 at the junction of CR10 and CR11.

The driver amplifier is composed of Q6 and Q7 thru Q10. The output driver, Q4, is mounted on the heat sink along with CR19. R28 is the current sense resistor. CR7 is the main power rectifier. R40 is a thermistor current surge suppressor. Fuse F3 was originally a 5A, 250V fuse, but this has been changed to a 7A, 250V fuse in all EMI1 units.

Control Board Connections

- LPS GROUND. The purple wire is soldered to T1-3, the center tap of the power input transformer secondary.
- POWER. The orange wire is soldered to the cathode of CR2, which is electrically the same point as the positive terminal of filter capacitor C3.
- START. The brown wire is soldered to the collector of Q5, which is also the control input to IC4, a triac-output opto-coupler used as the ignitor switch.
- CONTROL VOLTAGE. The white wire is soldered to the cathode of CR13, at the junction of the inverting input to current regulator amplifier IC2D.

3-8. EM11 LAMP POWER SUPPLY (CONT'D)

Common Failures

- AC POWER INPUT TERMINALS. The quick-disconnect spade terminals AC1-F and AC2 become loose and must be re-soldered.
- ON-BOARD FUSES. F1 and F3 should be checked for continuity using an ohmmeter. Some of the fuses are opaque so you can't tell by looking whether they are blown or still good. Sometimes they blow inside the end cap so they still look good.
- OUTPUT DRIVER. Unplug the connector to Q4, mounted on the big heat sink, and use the transistor checker on this device.
- DRIVER AMPLIFIER. Transistors Q7 thru Q10 must be removed from the circuit board to use the transistor checker, since most of their terminals are connected directly to each other. Also check Q6.
- OPERATIONAL AMPLIFIER. The socket-mounted quad op amp, IC2, can be replaced easily. Four different circuits are implemented using this device. Failure in any of the four circuits and cause the LPS to shut-down completely or to behave improperly.
- START PULSE CIRCUIT. IC2 and Q5 control operation of this circuit. Q5 disables the start pulse circuit after the lamp is lit. IC2 is the semiconductor switch that applies ac power to the voltage doubler. High voltage capacitors C23 and C21 fail occasionally. Check for faulty CR20.

3-9. EMI2 LAMP POWER SUPPLY

In this unit, IC10 (UC3524A) contains the oscillator and pulse-width modulator. The oscillator frequency is not adjustable. R113 is the on-board current adjustment. Q1 is the heat-sink mounted output driver. Q102 and Q103 are the driver amplifier components. Q104 is the start pulse switch. R124, R107, and C115 are the current sense network components.

Control Board Connections

- LPS GROUND. The purple wire is soldered to test point TP3.
- POWER. The orange wire is soldered to the junction of R5 and C5(+).
- START. The brown wire is soldered to the gate terminal of silicon-controlled rectifier (SCR) Q104.
- CONTROL VOLTAGE. The white wire is soldered to the jumper marked EXT PROG.

3-9. EMI2 LAMP POWER SUPPLY (CONT'D)

Common Failures

- AC POWER INPUT TERMINALS. Quick disconnect spade terminals become loose and must be re-soldered.
- FUSES. Check the on-board fuses using an ohmmeter. F101 has been changed from 5A 250V to 7A 250V in all units.
- OUTPUT DRIVER. Q1, mounted on the big heat sink, must be removed from the circuit to use the transistor checker on it since diode CR2 is connected directly across two of its terminals.
- INTEGRATED CIRCUIT. IC10 contains the bulk of the control circuits for the LPS and is easily replaced.
- START PULSE CIRCUIT. SCR Q104 is a high failure rate item. It can be checked in-circuit quite easily by connecting the transistor checker to CR107-cathode, TP3 (LPS ground), and the brown START wire. Also check high voltage capacitor C113 and high voltage diode CR109.
- MAIN POWER SUPPLY. Bridge rectifier CR105 should be checked (para. 2-11) for open or shorted legs. Filter capacitor C105 may become leaky and fail to develop the full 15 to 20 Vdc across it.

NOTE

The EMI2 LPS must be removed from the UPE before the circuit board can be removed.

3-10. TROUBLE WITH THE ACS RACK

The ACS Rack uses two repeater cards, accessible through a trap door in the bottom of the rack, to send data out two sides of the rack. Each card has two output connectors so, in case of failure, one card can serve both sides of the rack.

Troubleshooting

1. ONE SIDE BAD. If only one side of the rack is working, check for faulty repeater card on the bad side. You can connect the extra output from the remaining good card in place of the faulty repeater. Be sure to go back and repair the faulty repeater as soon as you have a chance.
 2. BOTH SIDES BAD. If neither side is working, disconnect the snake from the control rack and connect the test controller to the snake in place of the control rack. Now try to manipulate some lites with the test controller. If this works, the trouble is in the console and/or control rack, and not in the snake, ACS Rack, or repeaters. Refer to the VARI*LITE Console Troubleshooting Manual.
- If the test controller doesn't work through the snake, remove the snake from the hook-up and plug the test controller directly to the XLR connector on the ACS Rack. Now try again to manipulate some lites. If this works, the snake is faulty and must be repaired or replaced.
 - If the test controller plugged directly into the ACS Rack does not work, check for faulty repeater card(s). Hopefully you will not find two bad repeater cards, one hooked up and the other just laying there. If you do, you are in big trouble now (see 1. above). Refer to paragraph 3-11. Trouble With The Repeater, to repair repeater cards.

3-11. TROUBLE WITH THE REPEATER

Theory of Operation

The repeater card was designed to receive positive data through R5 to U3-1 and U3-3, and negative data through R6 to U3-2 and U3-4. If this were the case, positive data would be output from Q4/Q6 and negative data output from Q8/Q10 (see accompanying schematic diagram and parts locator). However, because the input header on the Data Receiver Card is labelled incorrectly, a series of control signal inversions exists in all implementations of the VARI*LITE 100 Series system. One part of this series of inversions occurs at the input to the repeater card.

Positive data at P1-3 (red wire) is applied through R6 to U3-2 and U3-4. Negative data at P1-2 (black wire) is applied through R5 to U3-1 and U3-3. The outputs at P2 and P3 are wired correctly, with positive data on pins 3, 6, & 9, and negative data on pins 1, 4, & 7. The terms "positive data" and "negative data" are conventions that have been established to correspond to the red and black color coded wires. What is "positive data" on the red wire at the repeater input becomes "negative data" on the black wire at the repeater output. If this sounds confusing, it is.

The situation, as of the date of publication of this manual, is this. The data output connector at the control rack is wired backwards. The repeater card in the ACS Rack inverts the control signal and passes it on. The repeater card in each repeater box inverts the signal again and passes it on. The input header on the Data Receiver Card in each luminaire is wired correctly according to the markings etched on the card, but the markings are backwards. This error on the Data Receiver Card is the root cause of the ensuing confusion.

The present situation is the result of several attempts to correct the problem. As long as there is an even number of repeater cards in the control signal path between the control rack and the luminaire, everything will be fine. Normally this will include one repeater in the ACS Rack and one repeater box in the truss. If you try to insert a repeater in the snake run, the system will not work. If you try to extend truss runs by connecting one repeater output to another repeater input, the outputs of the second repeater in the truss run will be inverted, and the luminaires connected to it will not work.

Troubleshooting

Refer to the parts locator and schematic diagrams when troubleshooting the repeater circuit card assembly. If the problem is not obvious, proceed as follows:

1. Verify proper operation of on-board power supply and voltage regulators.
2. Test circuit nodes with zero data input.

3-11. TROUBLE WITH THE REPEATER (CONT'D)

Troubleshooting (cont'd)

3. Test circuit nodes with positive data input.
4. Test circuit nodes with negative data input.

Test Data

Voltage measurements in the following table are approximate:

- 0 Vdc should be less than 0.8 Vdc;
- 5 Vdc should be greater than 2.4 Vdc;
- 15 Vdc should be greater than 10.0 Vdc.

TEST CONDITION:	POS. DATA	ZERO DATA	NEG. DATA
Input Parameters:			
+ Input (R5)/P1-1	+15 Vdc	0 Vdc	-15 Vdc
- Input (R6)/P1-3	-15 Vdc	0 Vdc	+15 Vdc
Test Data:			
U3-7	0 Vdc	+5 Vdc	+5 Vdc
Q1-collector	+5 Vdc	0 Vdc	0 Vdc
U3-6	+5 Vdc	+5 Vdc	0 Vdc
Q2-collector	0 Vdc	0 Vdc	+5 Vdc
U4-6	+15 Vdc	0 Vdc	-15 Vdc
+ output (R18/R19)	+15 Vdc	0 Vdc	-15 Vdc
U5-6	-15 Vdc	0 Vdc	+15 Vdc
- output (R26/R27)	-15 Vdc	0 Vdc	+15 Vdc

Possible Failures

- POWER SUPPLY/REGULATORS. If the +/-15v power supply is faulty, check for shorted 1.0 uf tantalum capacitors C3 thru C6. Also check for open rectifier diodes D1 thru D4 and shorted protection diodes D5 and D6. Verify correct resistance value of 1% resistors R1 thru R4. If no other fault is detected, replace U1 and/or U2. If the +5 Vdc regulator is faulty, replace VR1 and/or R7.
- SIGNAL PATH. Troubleshooting the signal path is straight-forward. If any stage has the correct input but an incorrect output, replace the active component and check for faulty associated components. Short-circuit current limiting devices Q3, Q5, Q7, and Q9, if shorted C-to-E, will shut-down output devices Q4, Q6, Q8, or Q10, respectively.
- CONNECTORS. Check for faulty connector pins. See schematic diagram and verify continuity as shown.

VARI*LITE
02-3002-0002

3-11. TROUBLE WITH THE REPEATER (CONT'D)

Component Diagram

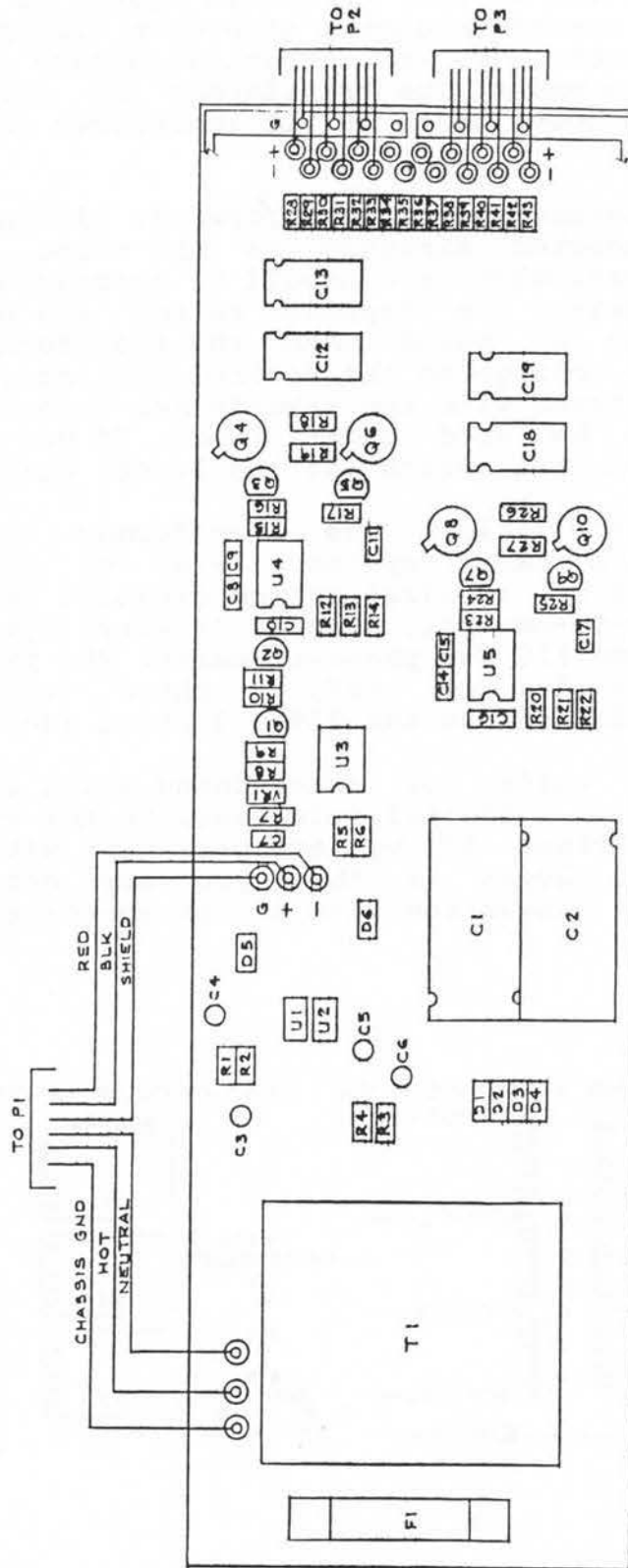

3-12. DELTA/WYE STEP-DOWN TRANSFORMER

Vari-Lite Europe has line voltages that are not 120V, thereby making the direct connection of the VARI*LITE system to the mains a problem. To this end, the operation uses a step-down transformer to convert the local mains to about 120V, the operating voltage required by VARI*LITE stage lighting equipment. The transformer is rated at 30 kVA and can safely be used to power up to 36 VLI luminaires and associated control equipment.

Use of the transformer is straight-forward, although as with any piece of equipment connected directly to the mains, it should be treated with respect. Particular care should be exercised when setting up the output voltage using the tapping switch and wye/delta switch. The tapping switch can be moved when the transformer is switched on to adjust the output voltage to the desired settings. The tapping switch must NEVER be altered with the transformer under load as the switches are not rated to be used under load. If you do change the output voltage under load, the switch (at the least) will be destroyed.

The wye/delta switch allows the transformer to be used on 360V, 3 phase, neutral, and earth systems (wye) or 208V 3 phase and earth systems (delta). A wye (5-wire) system exhibits 360 Vac phase-to-phase and 220 Vac phase-to-neutral. A delta (4-wire) system exhibits 208 Vac phase-to-phase and 110 Vac phase-to-earth. The prevalent distribution standard in Europe is the 360V, 3 phase (wye) system. Only a few countries or localities use the 208V, 3 phase (delta) system.

The most reliable guide for determining which system is in use at a particular venue is a digital voltmeter. Do not rely on the advise of the local electrician! If you are presented with a 5-wire wiring-in box, a good first guess is that you are dealing with a 360V wye system. Check the phase-to-phase and phase-to-neutral voltages to be sure.

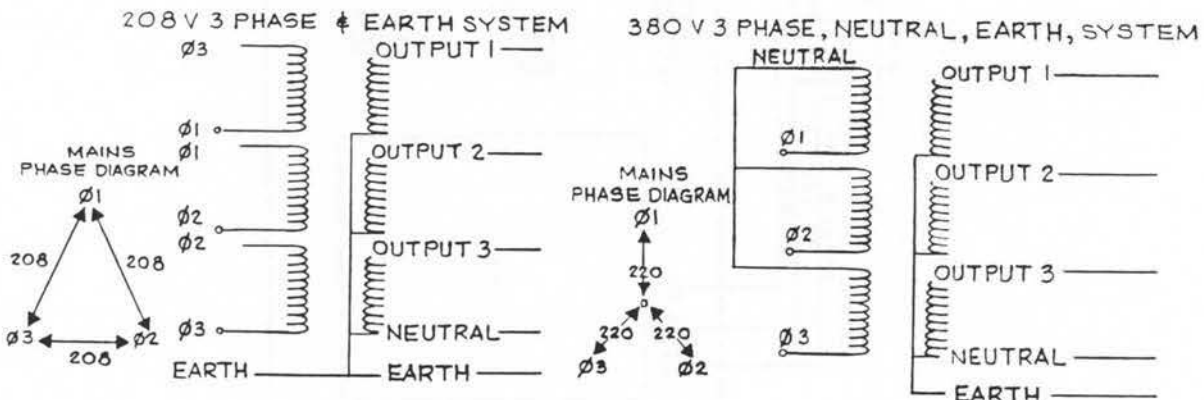

3-12. DELTA/WYE STEP-DOWN TRANSFORMER (CONT'D)

Set-up Procedure

1. Using a digital voltmeter, measure the mains voltages phase-to-phase and phase-to-neutral. If the phase-to-phase voltage is around 360 Vac, set the wye/delta switch to WYE. If the phase-to-phase voltage is only around 208 Vac, set the wye/delta switch to DELTA. Do not connect the neutral to a delta mains box even if five wires are provided.
2. Connect the transformer primary to the wiring-in box. Connect all five wires to a wye mains box. Connect only the three phases and earth to a delta mains box.
3. Ensure the VARI*LITE ACS rack is NOT connected to the transformer secondary, and set transformer power switch to ON. Verify all three phase indicators are lit.
4. Using the DVM, measure the transformer output voltages. Using the tapping switch, set the output voltage to about 124 Vac.
5. Set the transformer power switch to OFF.
6. Connect the ACS rack to the transformer secondary and proceed as usual. Be sure to connect all five wires from the transformer secondary to the ACS rack, regardless of how the primary is connected.

VARI*LITE 30kVA TRANSFORMER

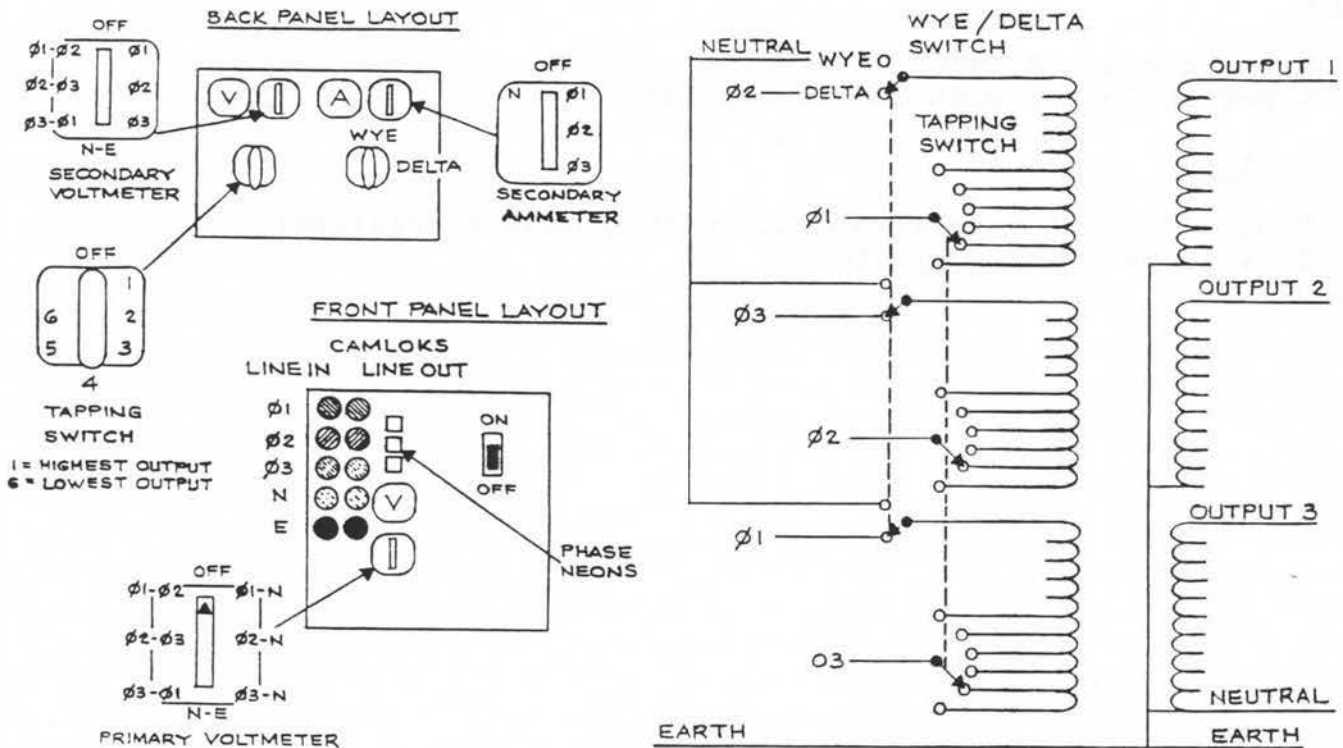

VARI*LITE
02-3002-0002

3-13. SHOP PRACTICES

Shop technicians at each Vari-Lite office should check, calibrate, clean, and lubricate each VL1 luminaire as it comes into the shop.

3-14. LUMINAIRE CHECK LIST

Check

1. Pan, tilt, and iris clutches; worm gear mesh and belt tightness.
2. Proper pan stop placement on 2nd and 3rd generation lites.
3. Gear mesh on wheel motors and feedback pots.
4. And eliminate chatter.
5. And compare 21 filters.
6. Gobo alignment and condition.
7. And heat shrink lamp wires in contact with data wires.
8. For loose and missing screws and rain cups.
9. For loose quick disconnects on lamp power supply.
10. For RTV in corners of recess.
11. And tie-wrap loose wires.

Calibrate

1. Pan and tilt: ZERO, SPAN, DAMP.
2. Lamp power supply: RUN (7.5A) and STANDBY (4.5A) current.
3. Iris: ZERO, SPAN, DAMP.
4. Color wheels: ZERO, SPAN, DAMP.
5. Beam wheel: ZERO, SPAN, DAMP.

Clean

1. Front glass and lens.
2. Upper enclosure with compressed air.

Lubricate

1. Pan, tilt, and iris worm gears with grease (versalube).
2. Iris leaves with graphite.

3-15. CABLE CHECK LIST

1. Always use cable checker.
2. Check for pushed-in pins.
3. Check strain relief for proper installation.
4. Make sure connector parts are screwed together tightly.
5. Replace broken or missing lock rings.
6. Check for proper color code tape on each end.
7. Visually inspect for cuts, bulges, et cetera.
8. Remove all old tape.
9. SILVER pins are used for AC power.
GOLD pins are used for DATA.
10. Apply contact cleaner to connector.
11. Make sure snakes and 2/0 cables are well bundled, except 100' lengths of 2/0.
12. Use tie lines on all trunk runs and snakes.
13. When repairing, ALWAYS refer to wiring diagram for color codes and pin-outs.

3-16. ACS RACK CHECK LIST

1. Fire-up 6 luminaires on each output connector.
2. Check for loose, damaged, or worn-out connectors.
3. Check for pushed-in pins.
5. Check switches and circuit breakers.
4. Replace broken or missing lock rings.
6. Check cam locks.
7. Check color-coding, pin numbers, and proper data on XLR connectors.
8. Vacuum-out rack.
9. Remove old tape.
10. Check casters, latches, and lid fit.
11. Check Edison plug for 120 Vac.
12. Check repeater cards and see that both are working, and plugged in properly.

3-17. ROAD CASE CHECK LIST

1. Check and replace latches.
2. Check and replace casters.
3. Inspect foam.
4. Watch for hard foam cases with soft bottoms.
5. Inspect retaining chains on cable trunks.
6. Repair torn carpet.

NOTE

Remember to fill out Maintenance Logs.

Section III. DIAGRAMS

3-18. SCHEMATIC DIAGRAMS

Schematic diagrams for circuit card assemblies appear on the following fold-out pages.

- DC POWER SUPPLY/LUMINAIRE BLOCK DIAGRAM: Page 3-31.
- DATA RECEIVER: Page 3-33.
- SERVO POWER SUPPLY: Page 3-37.
- GE LAMP POWER SUPPLY: Page 3-39.
- EMI1 LAMP POWER SUPPLY: Page 3-41.
- EMI2 LAMP POWER SUPPLY: Page 3-43.
- LAMP POWER SUPPLY CONTROL BOARD: Page 3-45.
- WHEEL SERVO BOARD: Page 3-46.

3-19. POWER AND SIGNAL DISTRIBUTION EQUIPMENT

Assembly drawings and wiring (or schematic) diagrams for power and signal distribution equipment are provided as follows:

- CONSOLE SNAKE: Page 3-48.
- ACS RACK: Page 3-49.
- TRUNK CABLE: Page 3-51.
- LAMP CABLE: Page 3-51.
- REPEATER CARD: Page 3-53.

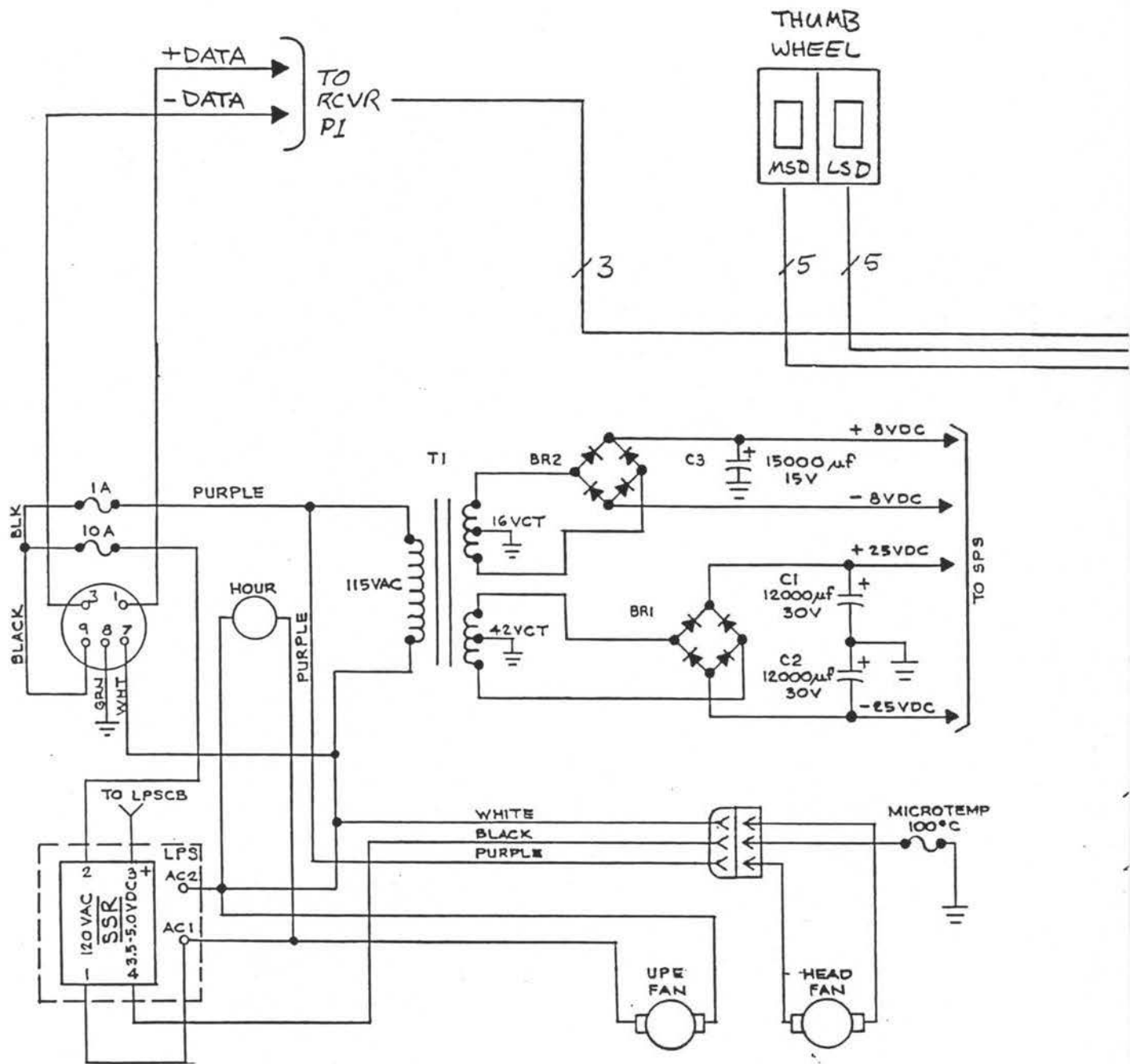

SCHEMATIC DIAGRAM
DC Power Supply

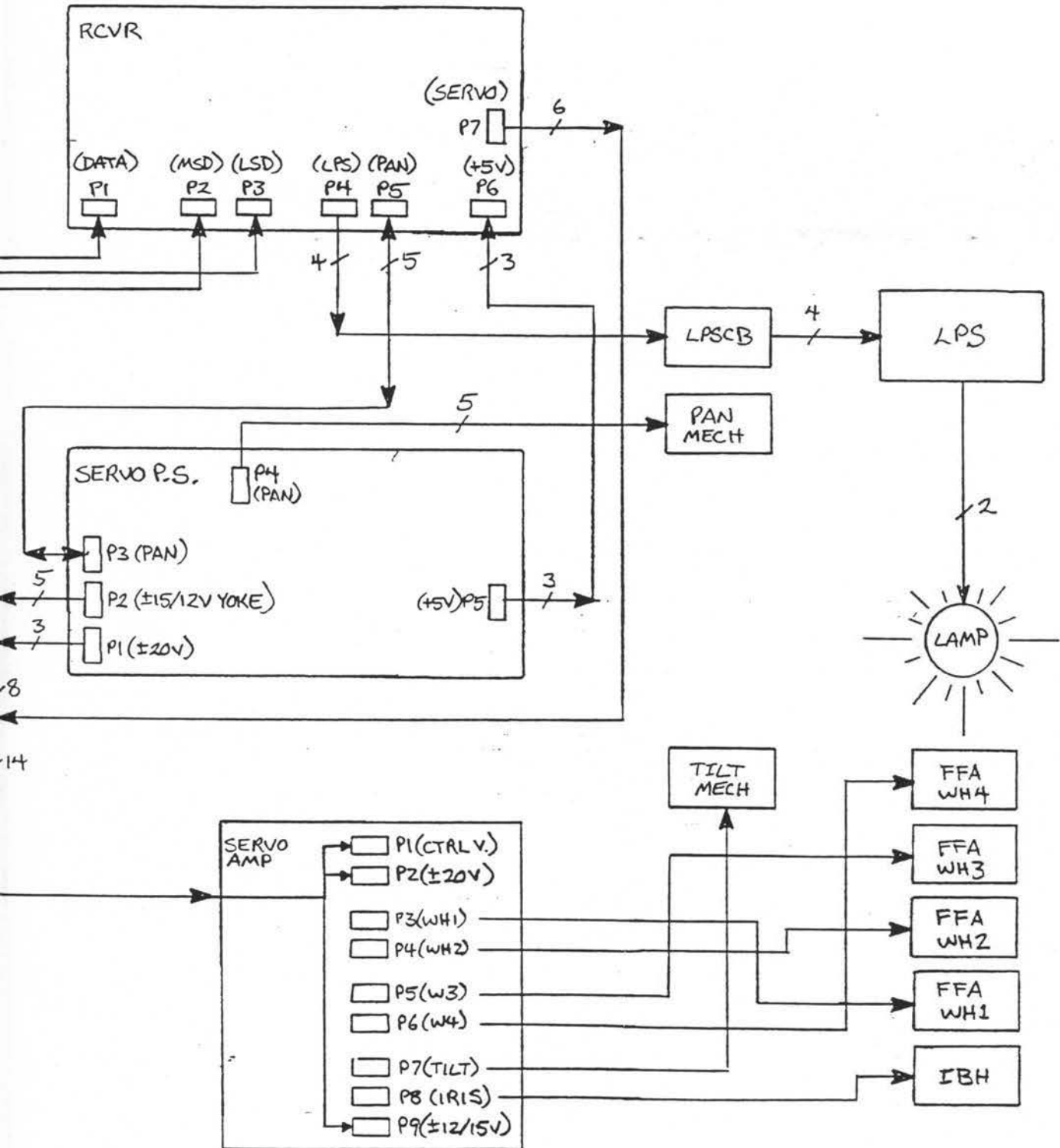

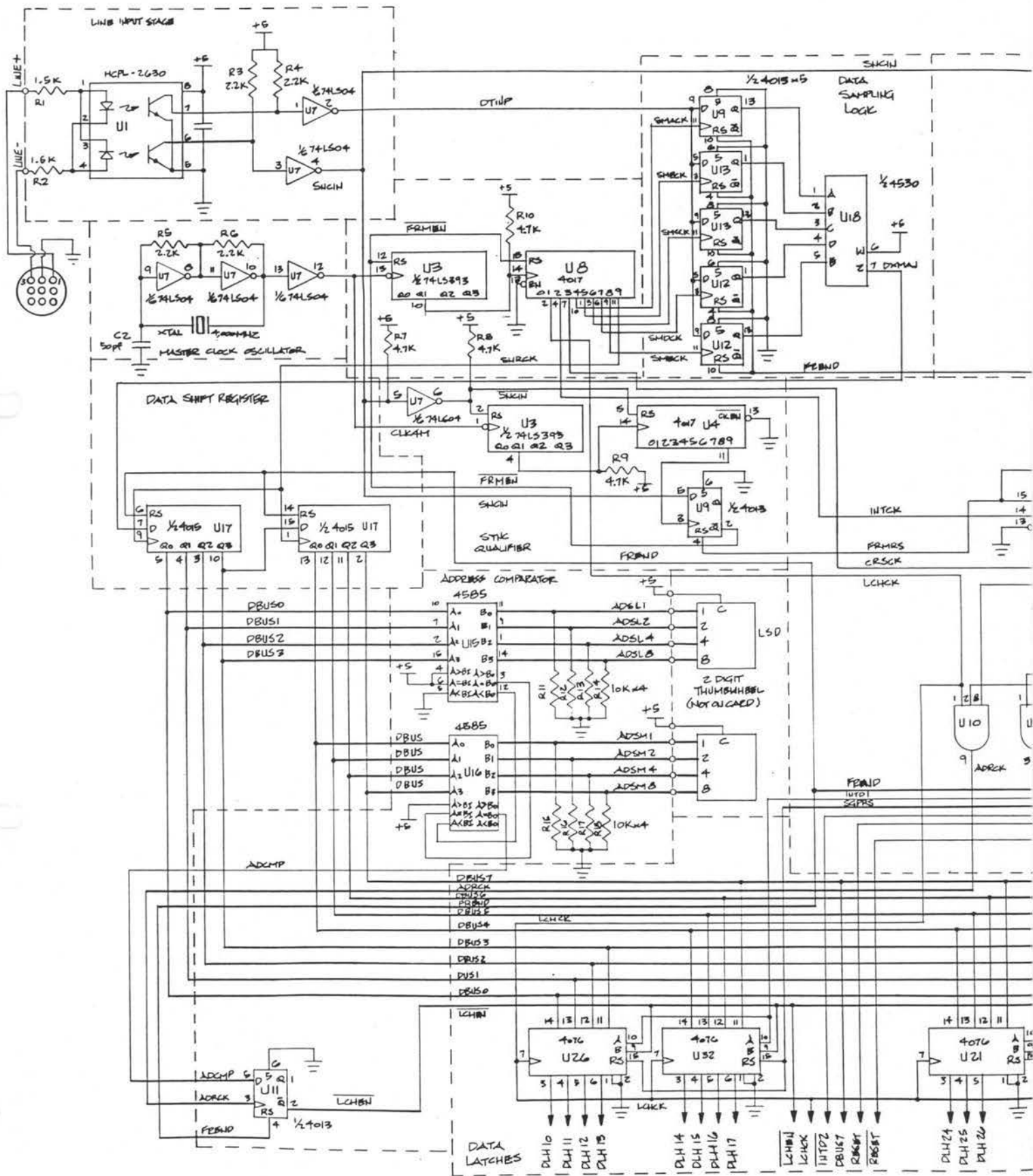

SCHMATIC DIAGRAM
Data Receiver
Sheet 1 of 2

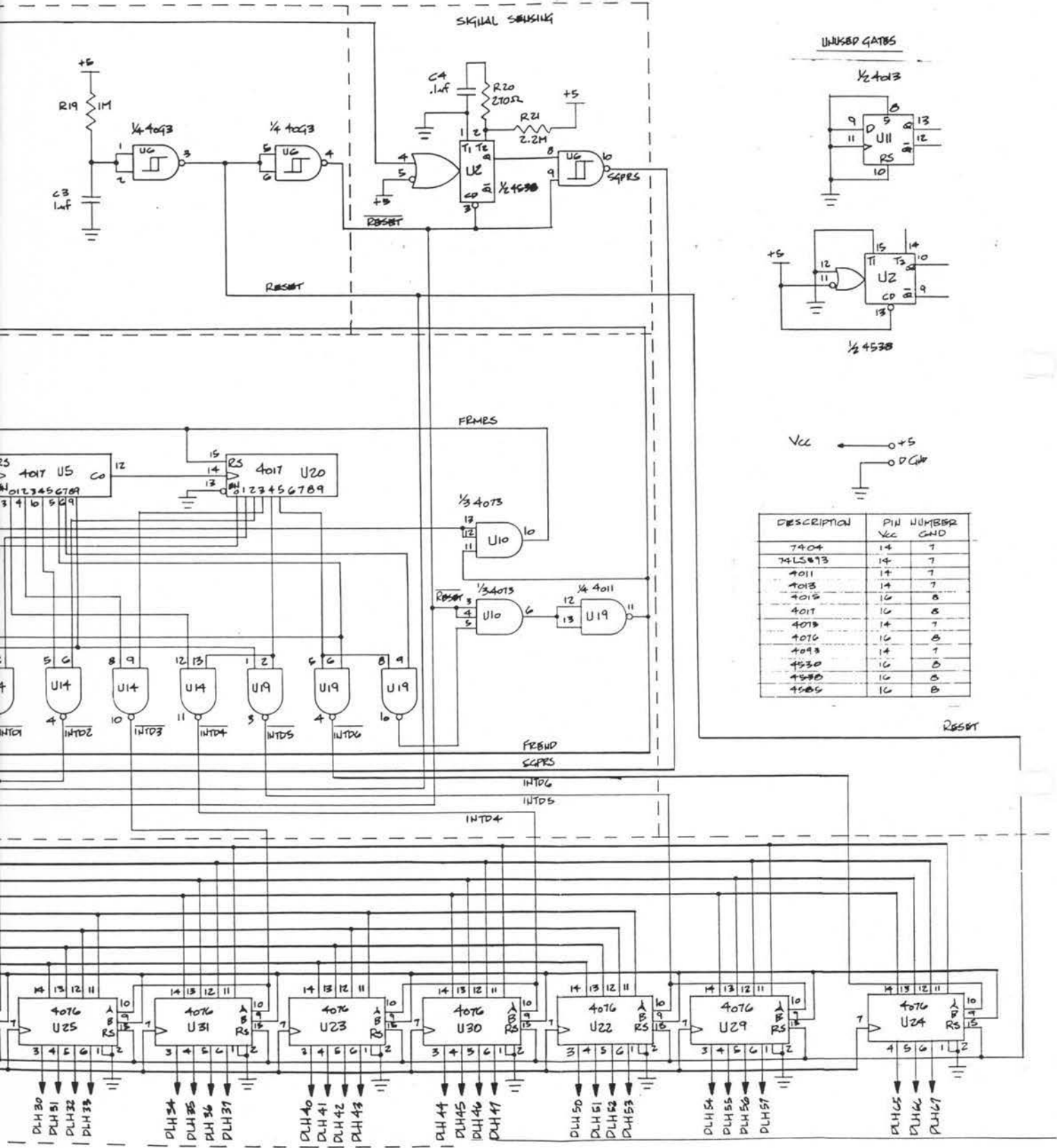

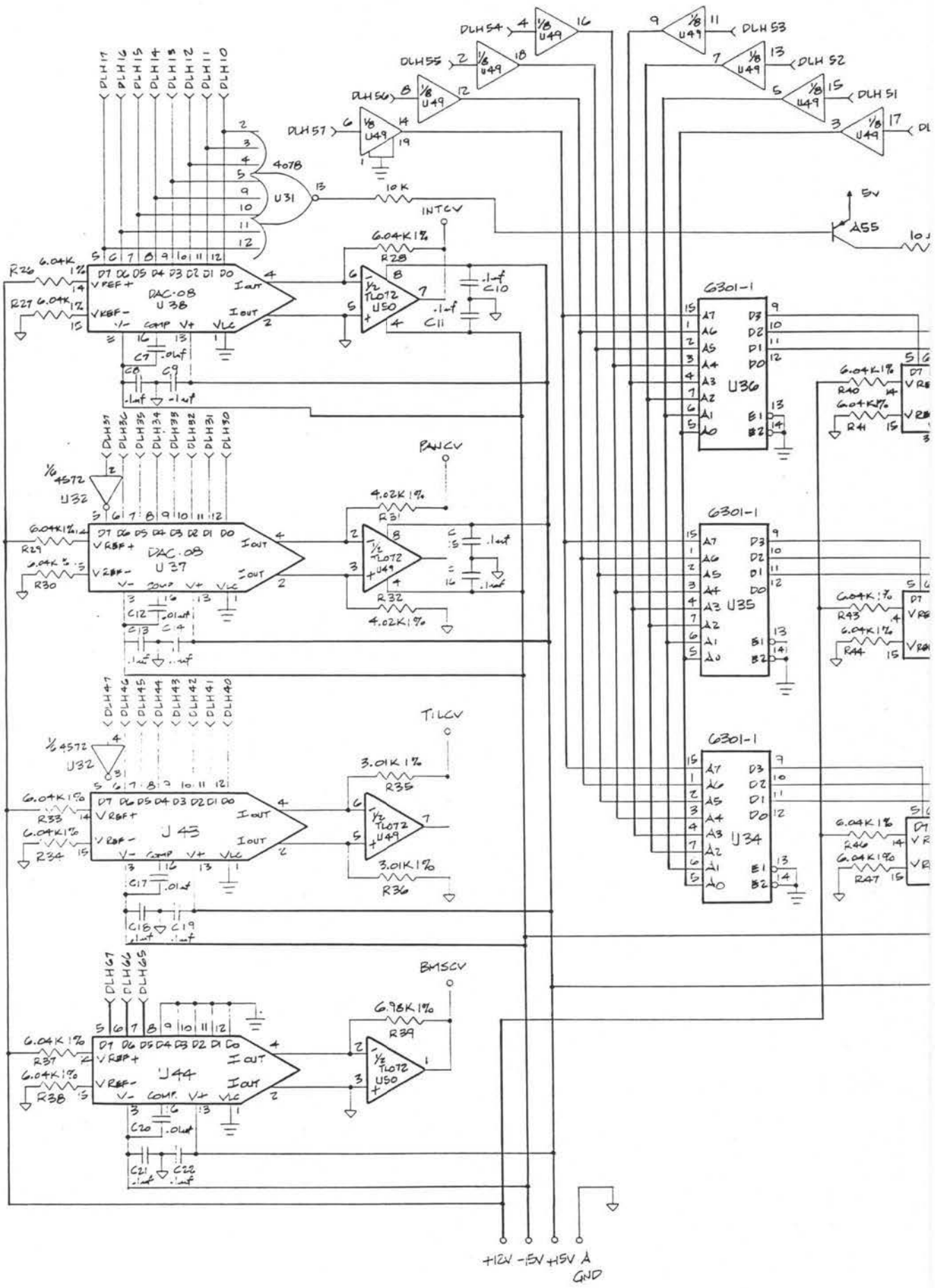

SCHEMATIC DIAGRAM
Data Receiver
Sheet 2 of 2

450

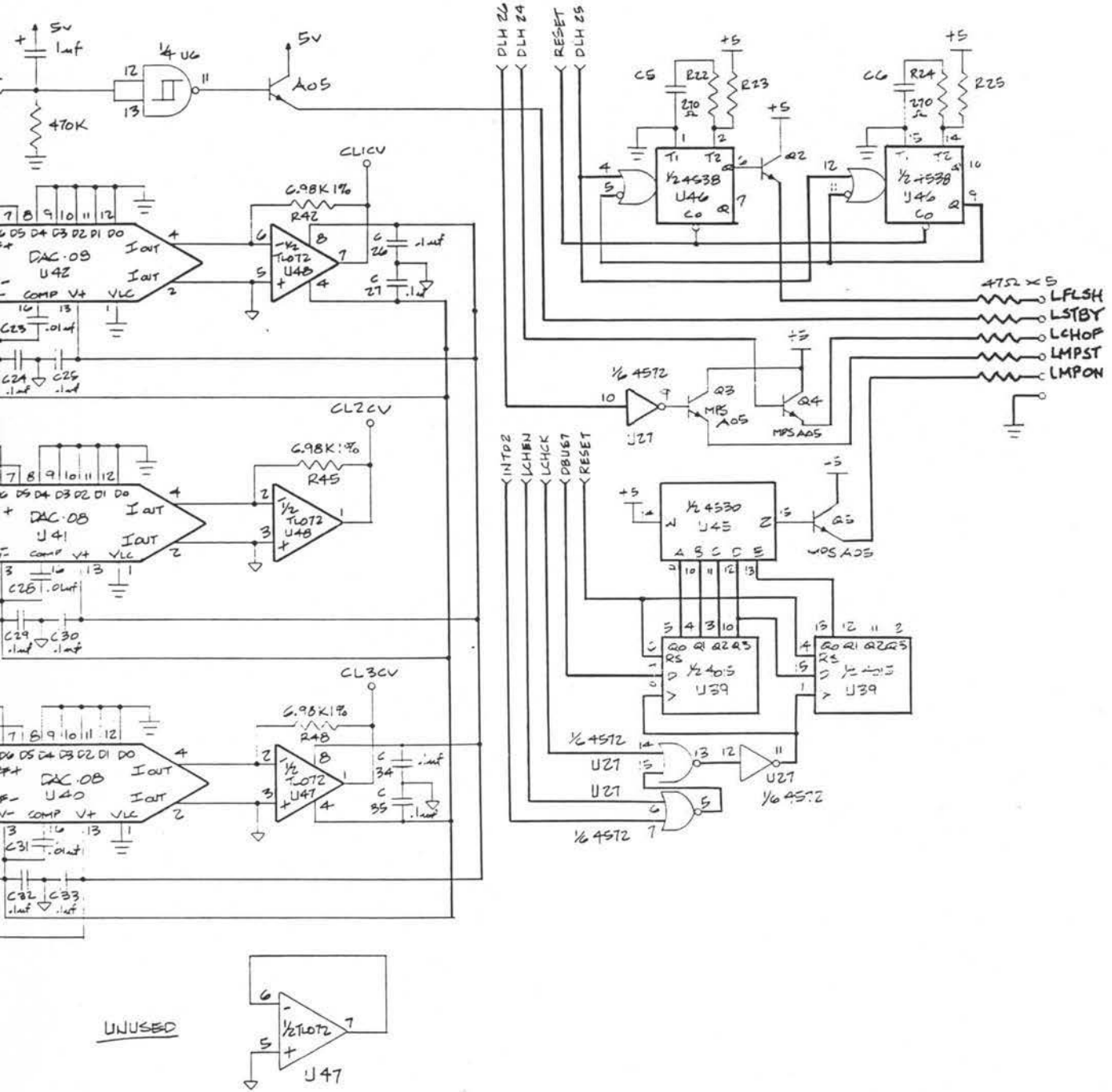

UNUSED

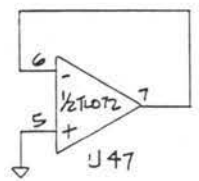

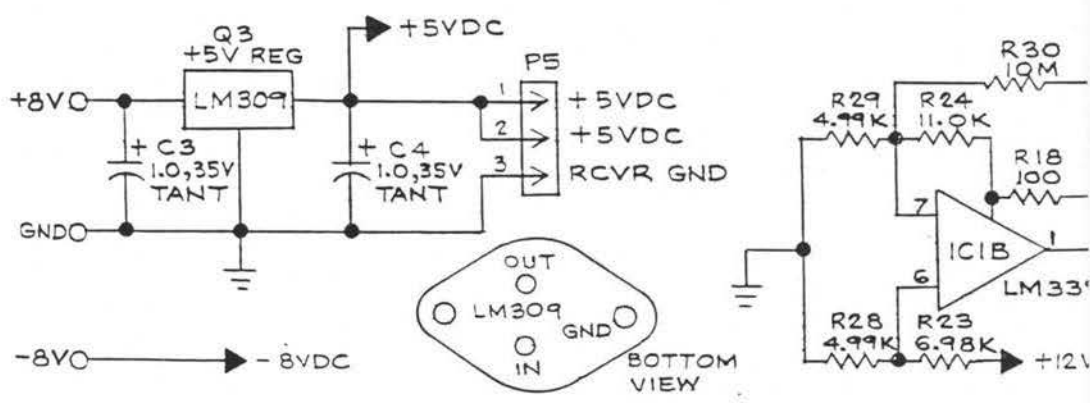
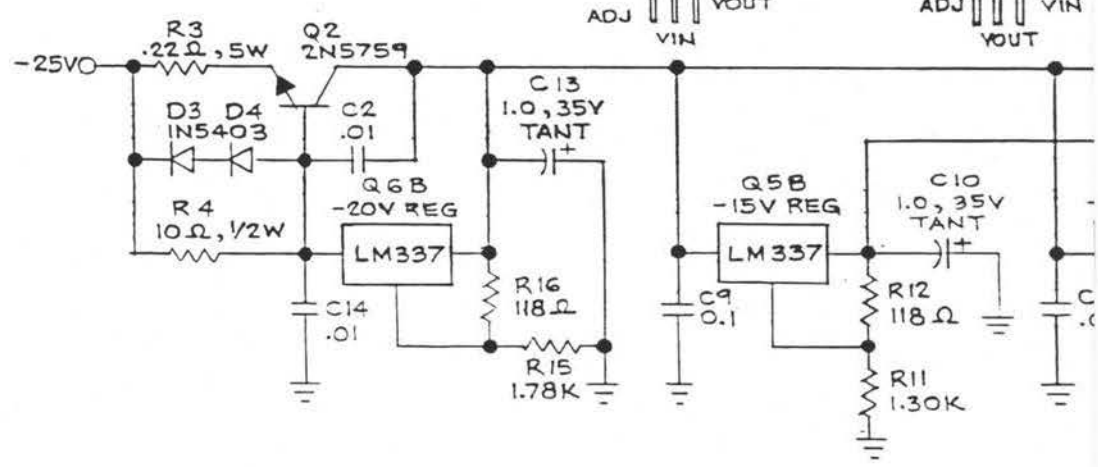
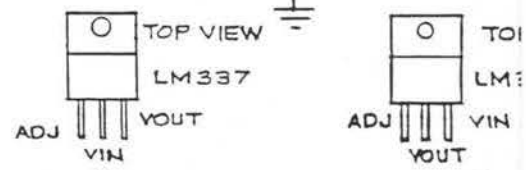
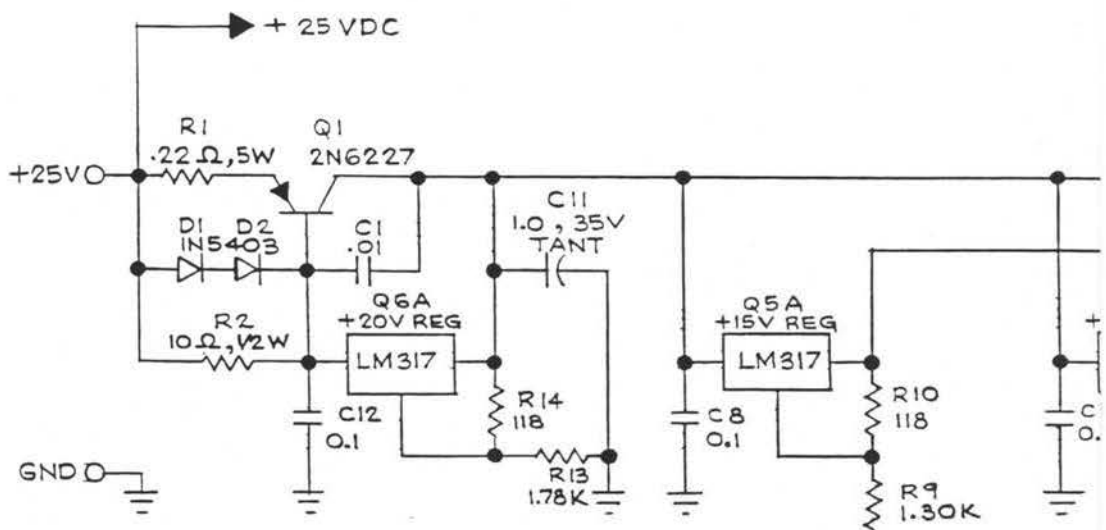

SCHEMATIC DIAGRAM
Servo Power Supply

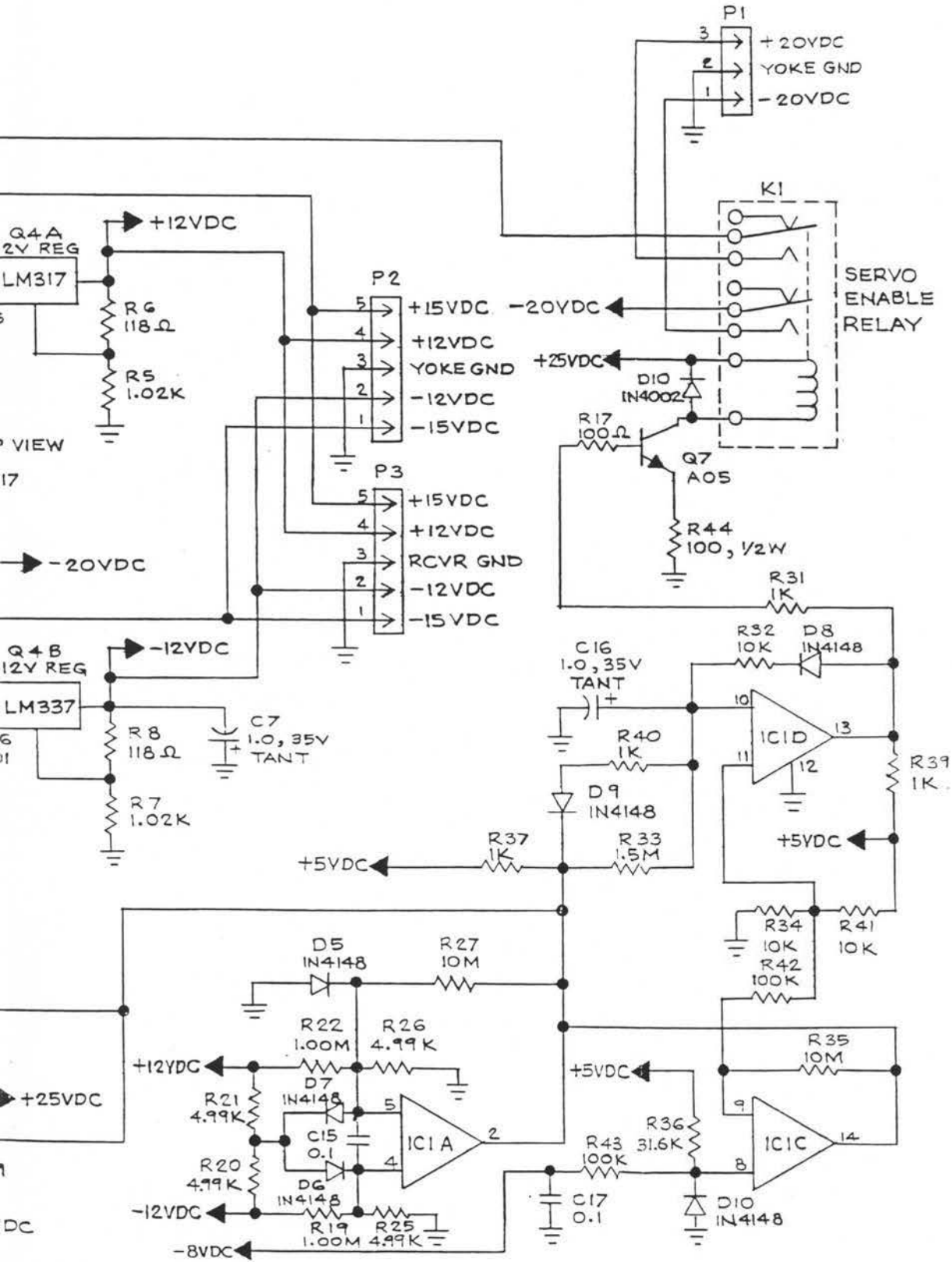

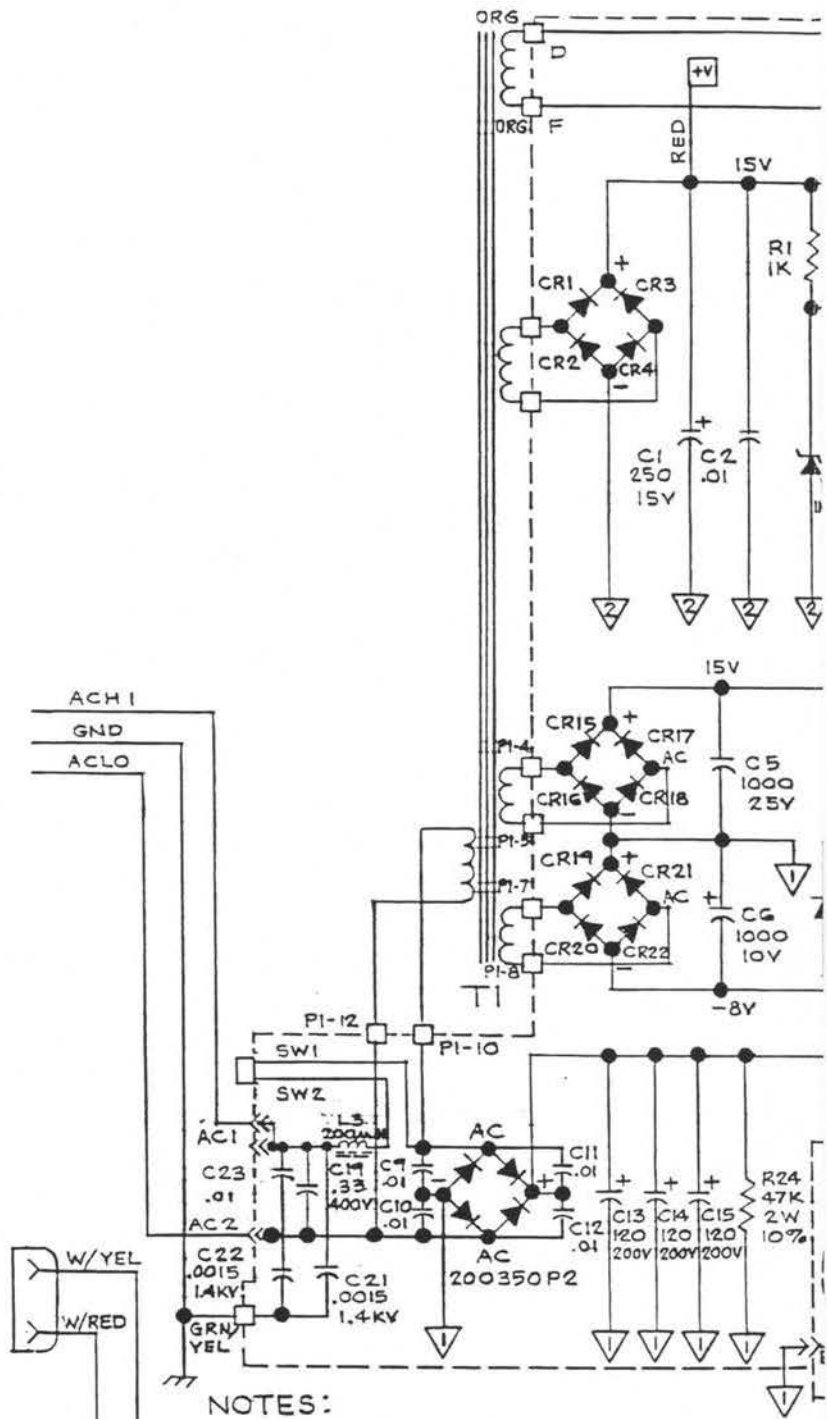

NOTES:
 ALL CAPACITOR VALUES ARE IN MICROFARAD
 AND RATED 1.0 KV UNLESS NOTED.
 LAST COMP. USED R32, CR24, C26, YR3,
 ALL RECTIFIERS ARE IN4004 UNLESS NOTED
 ALL RESISTORS VALUES ARE IN OHMS 1/2W

SCHEMATIC DIAGRAM
GE Lamp Power Supply

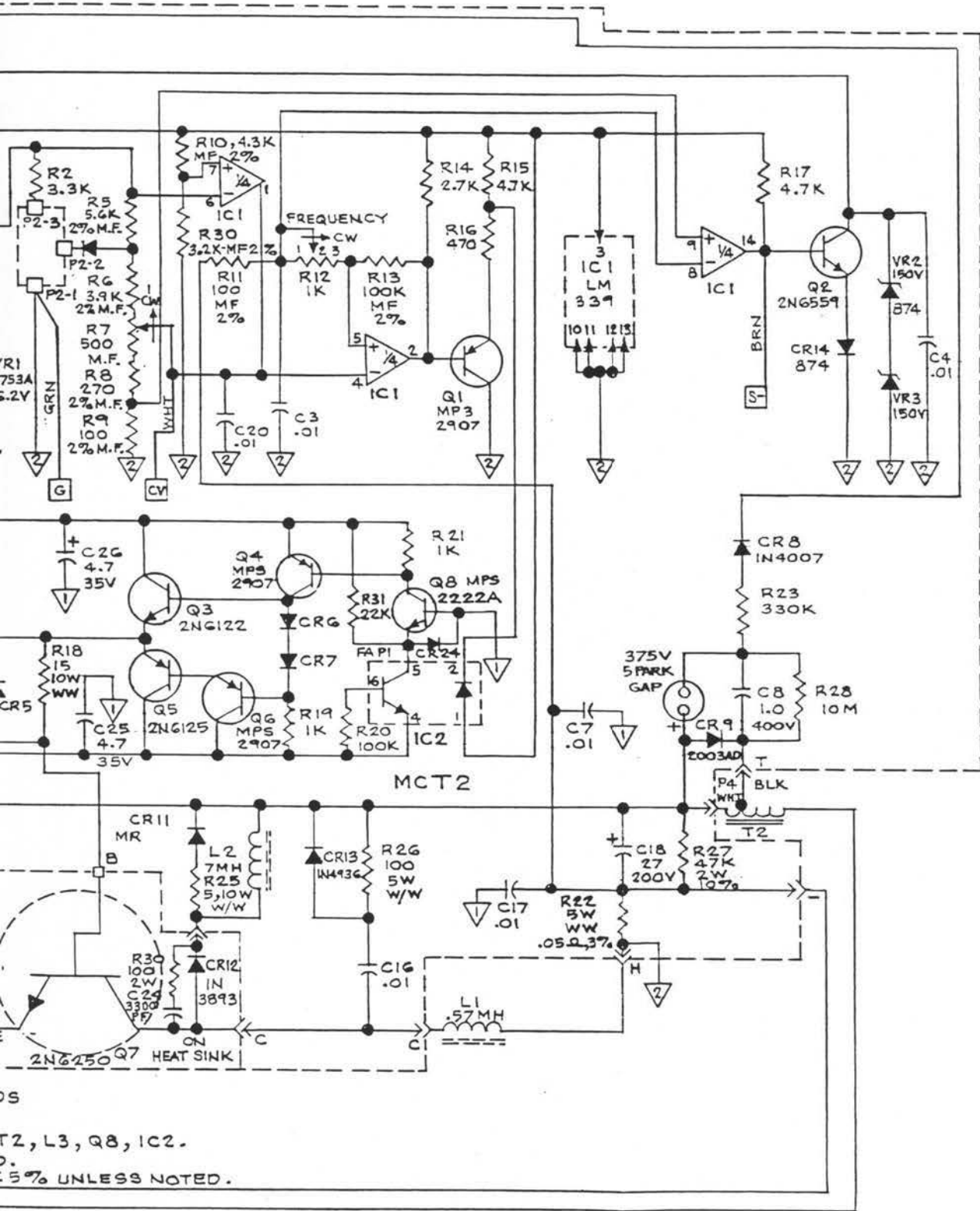

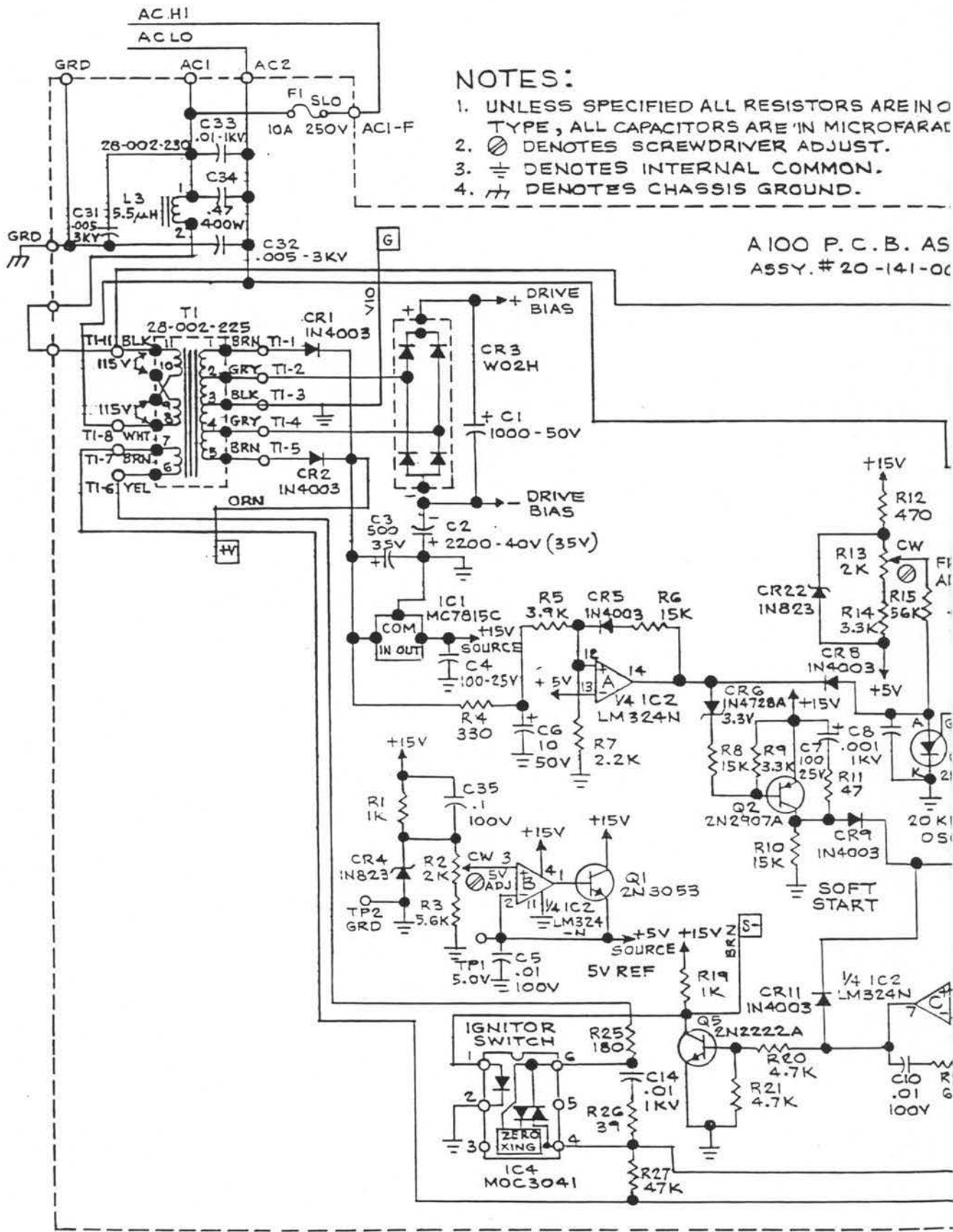

NOTES:

1. UNLESS SPECIFIED ALL RESISTORS ARE IN Ω TYPE, ALL CAPACITORS ARE IN MICROFARAD
2. ⊗ DENOTES SCREWDRIVER ADJUST.
3. ⊕ DENOTES INTERNAL COMMON.
4. ⏏ DENOTES CHASSIS GROUND.

A100 P.C.B. AS
 ASSY. # 20-141-00

SCHEMATIC DIAGRAM
EMIL Lamp Power Supply

RESISTORS ARE 1/2W 5% COMPOSITION
S:K=1.000 M=1,000.000.

INPUT:
STD 100-130V 50/60HZ
OPTION 175-260V 50/60HZ

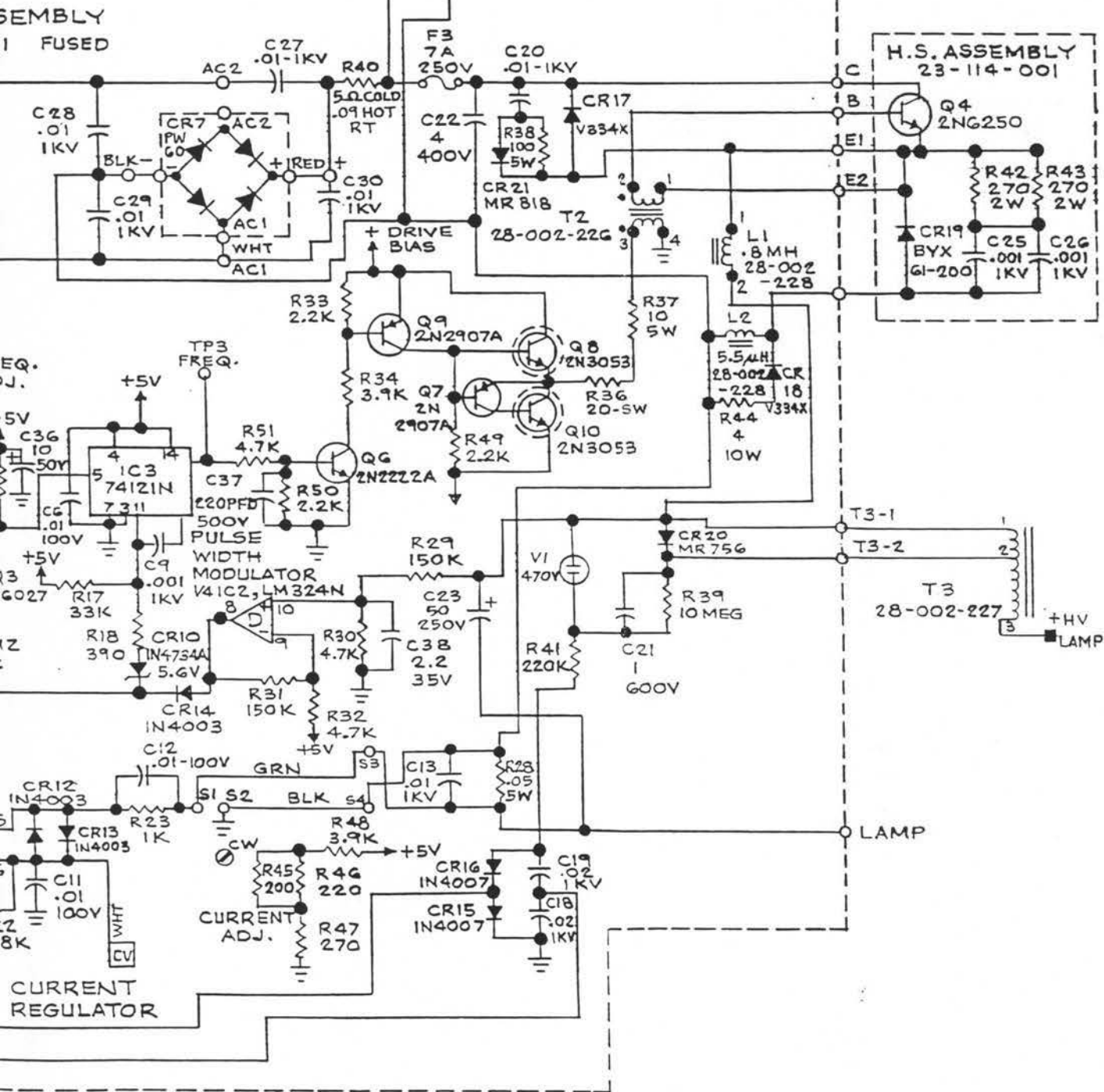

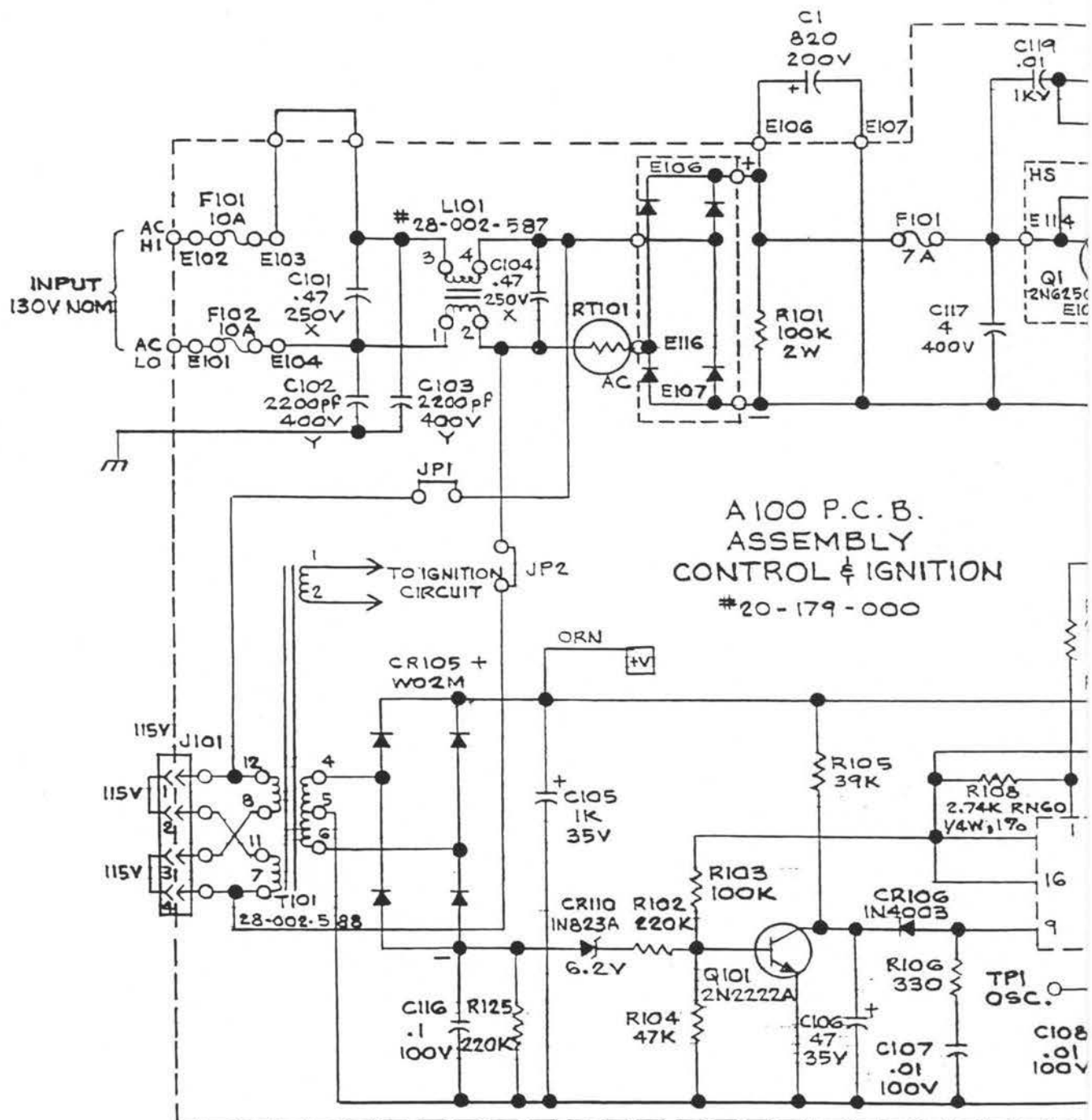

NOTES:

1. UNLESS OTHERWISE SPECIFIED ALL RESISTORS ARE IN ARE 1/2W, 5% COMPOSITION TYPE, ALL CAPACITORS ARE 1/2W, 5% COMPOSITION TYPE, ALL CAPACITORS: K = 1,000 M = 1,000,000
2. ⊗ DENOTES SCREWDRIVER ADJUST.
3. ⏏ DENOTES CHASSIS GROUND.

VARI*LITE
02-3002-0002

SCHEMATIC DIAGRAM
EMI2 Lamp Power Supply

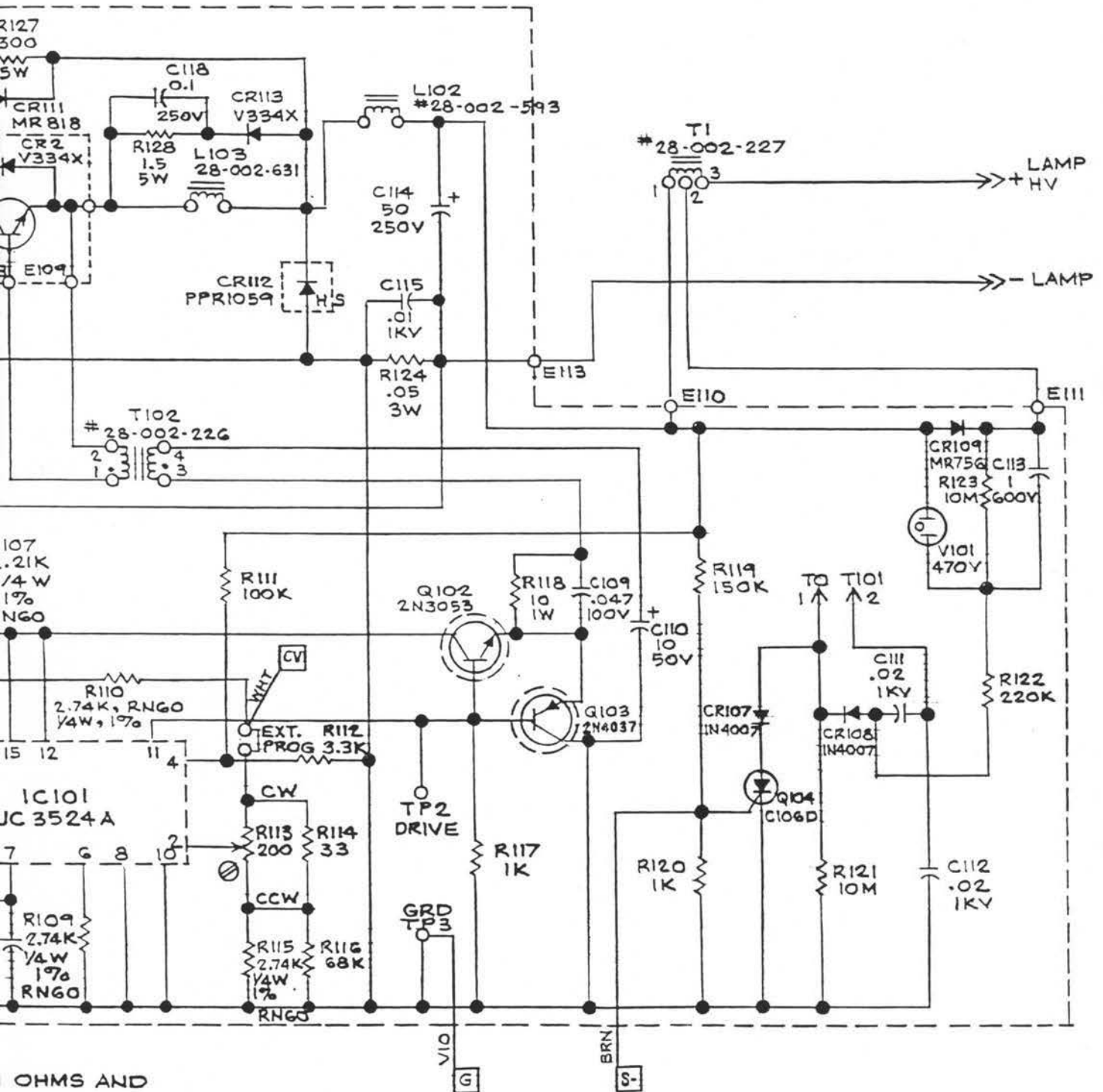

OHMS AND
ARE IN MICROFARADS.

VARI*LITE
02-3002-0002

SCHEMATIC DIAGRAM
Lamp Power Supply Control Board

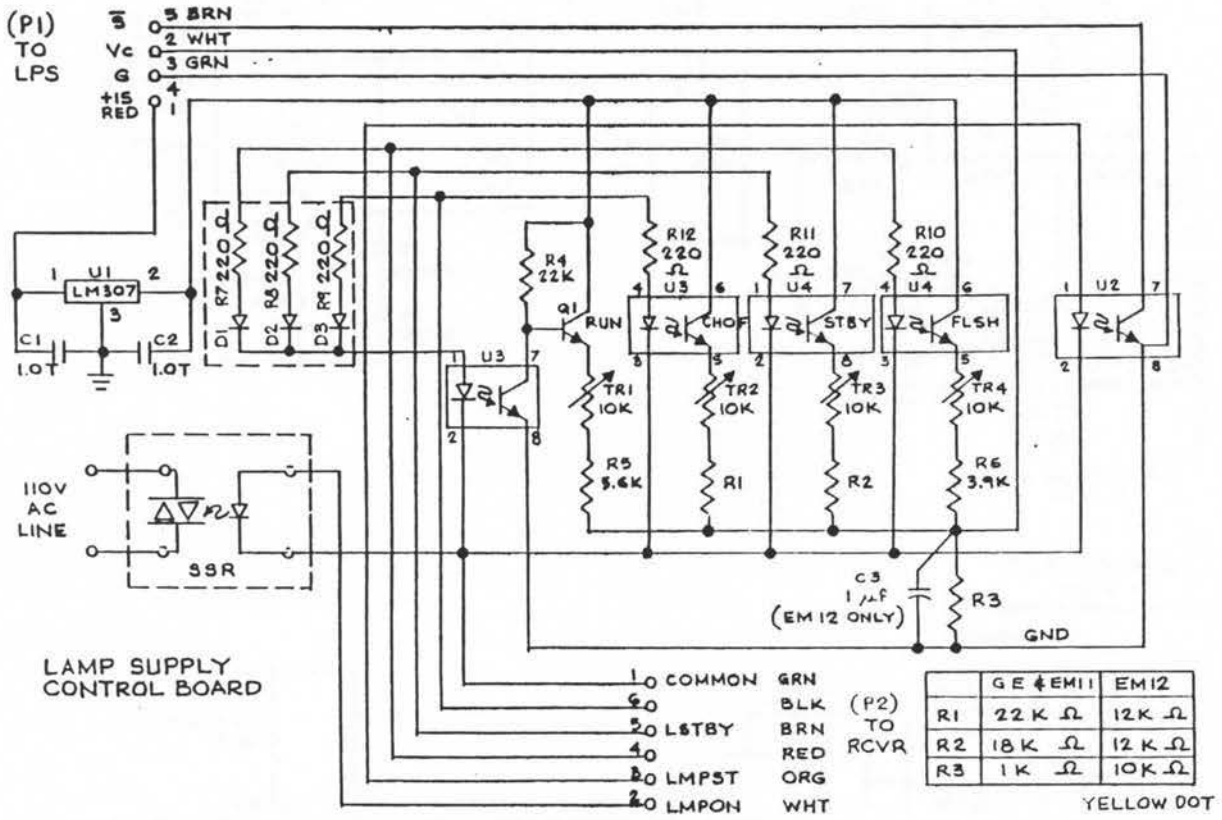

VARI*LITE
02-3002-0002

SCHEMATIC DIAGRAM
Wheel Servo Board
Sheet 1 of 2

SERVO INPUT

○ → +12V
○ V = WHITE

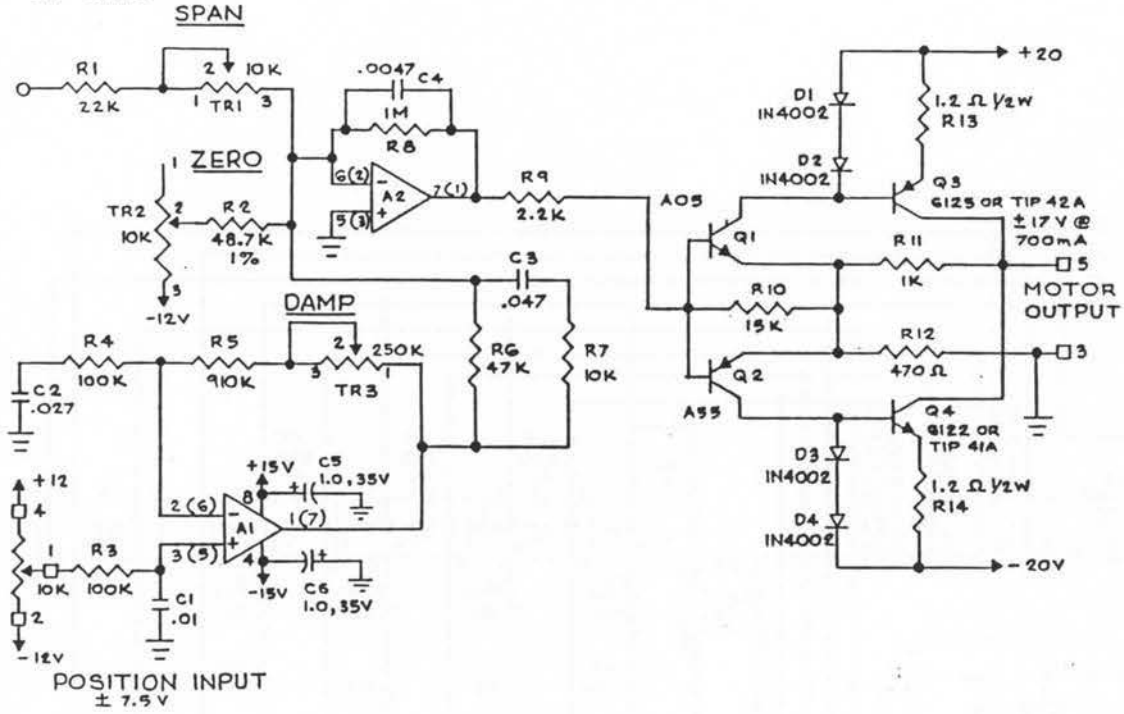

SERVO INPUT

○ → +12V
○ V = IR15 CLOSED

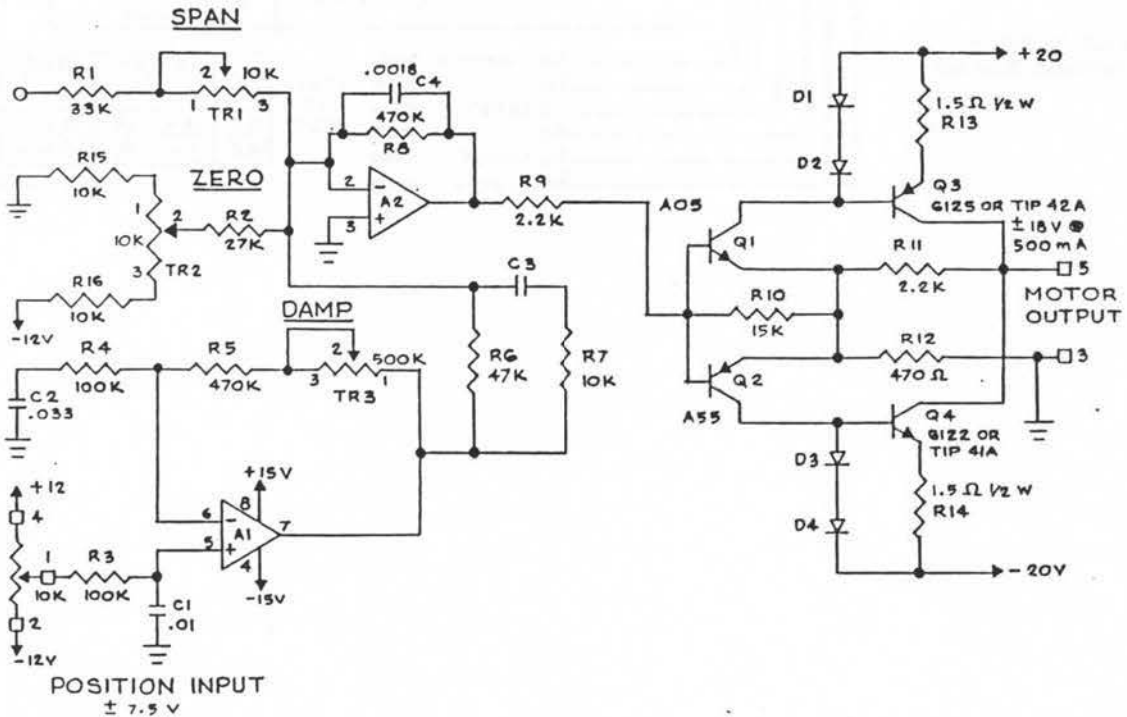

VARI*LITE
02-3002-0002

SCHEMATIC DIAGRAM
Wheel Servo Board
Sheet 2 of 2

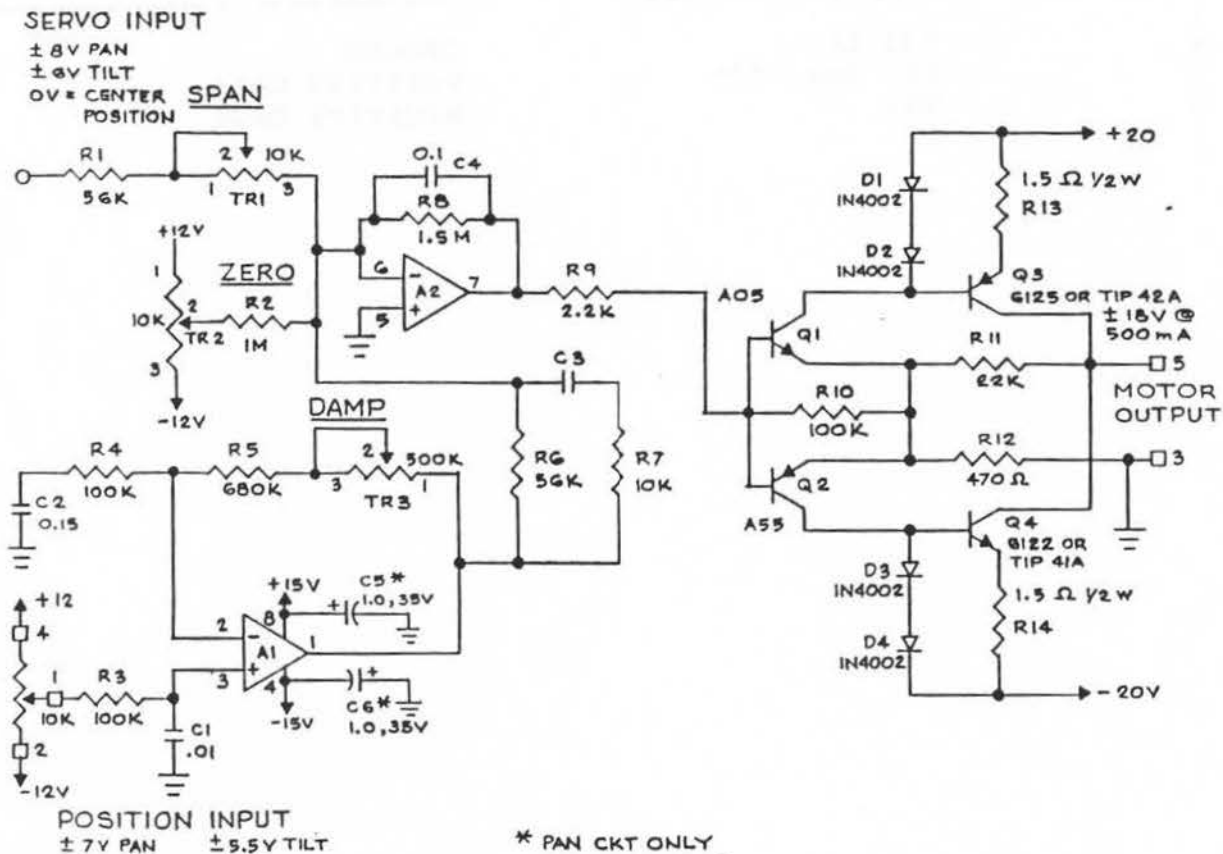

VARI*LITE
02-3002-0002

WIRING DIAGRAM
Console Snake

XLR CONNECTOR

<u>PIN</u>	<u>WIRE COLOR</u>	<u>FUNCTION</u>
1	SHEILD	GROUND
2	RED (or WHT)	POSITIVE DATA
3	BLK	NEGATIVE DATA

9-PIN REPEATER OUTPUTS

<u>PIN#</u>	<u>COLOR</u>	<u>AS</u>
1	BLACK	NE
2	WHITE	GR
3	RED	PO
4	BLACK	NE
5	WHITE	GR
6	RED	PO
7	BLACK	NE
8	WHITE	GR
9	RED	PO

WIRING DIAGRAM
ACS Rack

ASSIGNMENT
NEGATIVE DATA
GROUND
POSITIVE DATA
NEGATIVE DATA
GROUND
POSITIVE DATA
NEGATIVE DATA
GROUND
POSITIVE DATA

<u>PIN#</u>	<u>OLD 24-PIN</u>	<u>NEW 24-PIN (WITH LOGO)</u>	<u>ASSIGNMENT</u>
1	BLACK	BLACK	NEUTRAL
2	BROWN	BROWN	GROUND
3	RED	RED	HOT (X)
4	ORANGE	ORANGE	NEUTRAL
5	YELLOW	YELLOW	GROUND
6	GREEN	GRN./YEL	HOT (X)
7	BLUE	BLUE	NEUTRAL
8	VIOLET	VIOLET	GROUND
9	GREY	GREEN/BLACK	HOT (Y)
10	WHITE	GREEN/ORANGE	NEUTRAL
11	WHITE/BLACK	WHITE/BLACK	GROUND
12	WHITE/BROWN	WHITE/BROWN	HOT (Y)
13	WHITE/RED	WHITE/RED	NEUTRAL
14	WHITE/ORANGE	WHITE/ORANGE	GROUND
15	WHITE/YELLOW	WHITE/YELLOW	HOT (Z)
16	WHITE/GREEN	GREEN/BROWN	NEUTRAL
17	WHITE/BLUE	WHITE/BLUE	GROUND
18	WHITE/VIOLET	WHITE/VIOLET	HOT (Z)
19	WHITE/GREY	GREEN/VIOLET	NEUTRAL
20	WHITE/BLK/BRN	GREEN/BLUE	GROUND
21	WHITE/BLK/RED	GREEN/RED	HOT
22	BLACK #18 AWG	BLACK	NEGATIVE DATA
23	SHIELD	SHIELD	GROUND
24	RED (OR WHITE) #18	WHITE	POSITIVE DATA

NOTE: GREEN/BROWN AND GREEN/RED ARE DANGEROUSLY SIMILAR IN THE NEW 24-PIN CABLE

9-PIN CONNECTOR

<u>PIN #</u>	<u>COLOR</u>	<u>ASSIGNMENT</u>
1	BLACK #22 AWG	NEGATIVE DATA
2	SHIELD #22 AWG	GROUND
3	RED (OR WHITE) #22 AWG	POSITIVE DATA
4	BLANK	
5	BLANK	
6	BLANK	
7	BLACK	NEUTRAL
8	BROWN	GROUND
9	RED	HOT

XLR CONNECTOR

<u>PIN #</u>	<u>COLOR</u>	<u>ASSIGNMENT</u>
1	SHIELD	GROUND
2	RED (OR WHITE)	POSITIVE DATA
3	BLACK	NEGATIVE DATA

WIRING DIAGRAM
Trunk Cable
Lamp Cable

NEW 34-PIN CABLE

<u>PIN#</u>	<u>COLOR</u>	<u>ASSIGNMENT</u>
1	BLACK	NEUTRAL
2	BROWN	GROUND LAMP 1
3	RED	HOT (X)
4	ORANGE	NEUTRAL
5	YELLOW	GROUND LAMP 2
6	TAN	HOT (X)
7	BLUE	NEUTRAL
8	VIOLET	GROUND LAMP 3
9	GREY	HOT (Y)
10	PINK	NEUTRAL
11	WHITE/BLACK	GROUND LAMP 4
12	WHITE/BROWN	HOT (Y)
13	WHITE/RED	NEUTRAL
14	WHITE/ORANGE	GROUND LAMP 5
15	WHITE/YELLOW	HOT (Z)
16	WHITE/TAN	NEUTRAL
17	WHITE/BLUE	GROUND LAMP 6
18	WHITE/VIOLET	HOT (Z)
19	WHITE/GREY	NEUTRAL
20	WHITE/PINK	GROUND REPEATER
21	GREEN/BLACK	HOT
22	BLACK	NEGATIVE DATA
23	SHIELD	GROUND
24	WHITE	POSITIVE DATA

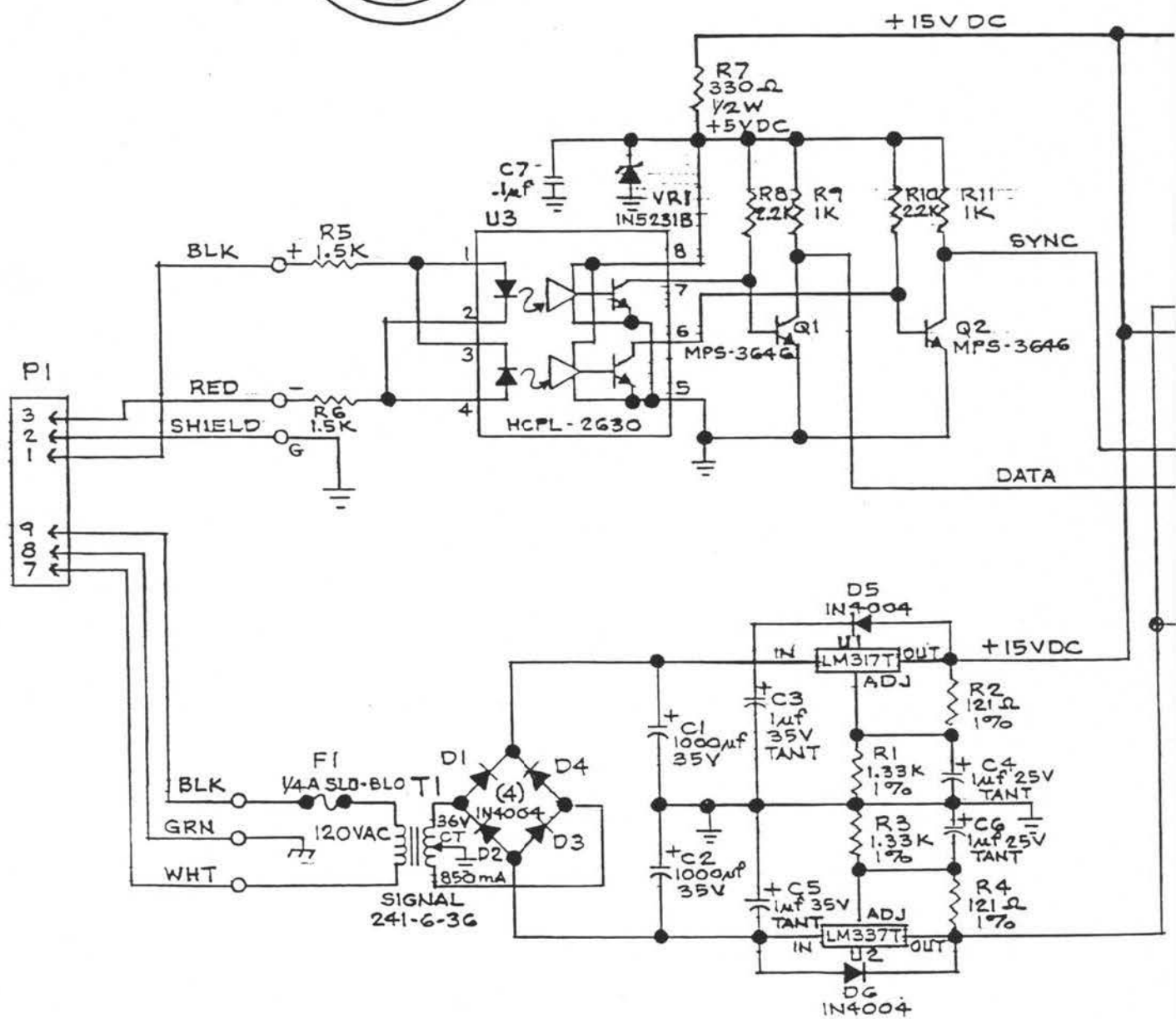
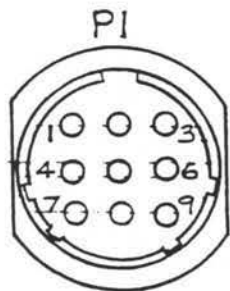

SCHEMATIC DIAGRAM
Repeater Card

P2/P3

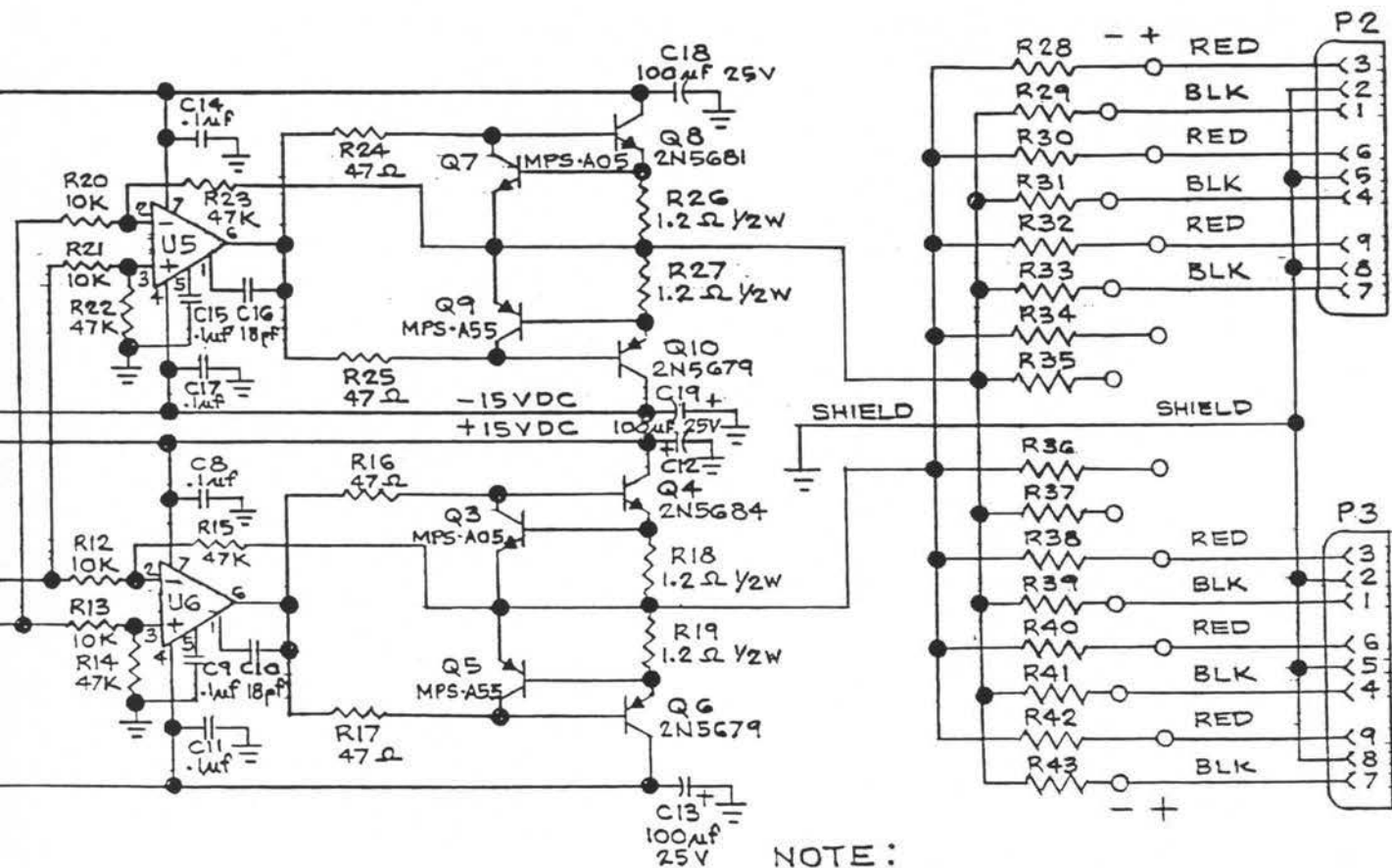
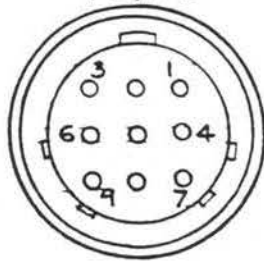

NOTE:
R28 THRU R43 = 39 Ω
U5 & U6 ARE LM318H

CHAPTER 4

ILLUSTRATED PARTS BREAKDOWN

Section I. INTRODUCTION

4-1. HOW TO READ THE PARTS LIST

In section II. Illustrated Parts List, exploded view drawings are provided to illustrate the location and manner of assembly of the various parts in the VARI*LITE 1 spot luminaire. The parts list which accompanies each illustration begins with the following heading:

INDEX NO.	PART NUMBER	DESCRIPTION						QUAN	USABLE
		1	2	3	4	5	6	PER	ON
		ASSY	CODE

Parts information is given in five columns under the headings as follows:

- INDEX NO. The number in this column keys the parts information to the illustration of the part.
- PART NUMBER. This is the identifying number of the part. Vari-Lite part numbers are used where available. Vendor part numbers are used otherwise. If no part number is given, refer to the description for complete identifying information.
- DESCRIPTION. This column shows the subordinate relationship of the various piece parts and sub-assemblies to the main assembly. The main assembly (in each illustration) is listed first, beginning under the number 1 in the heading. Each piece part and sub-assembly of the main assembly is listed in index number order, beginning under the number 2 in the heading. A dot appears under the number 1 to indicate the 1st indenture. Piece parts of sub-assemblies (and sub-sub-assemblies, too) are listed beginning under the number 3, with dots under 1 and 2 to indicate the 2nd indenture. Up to six indenture levels may be indicated in this format.

4-1. HOW TO READ THE PARTS LIST (CONT'D)

- ATTACHING PARTS. Hardware used to secure parts and sub-assemblies are noted by (AP) in the description, following the noun name. Attaching parts are listed following the part or sub-assembly they secure. If attaching parts have no index number, they will be indented one level below the part they attach, and no callout will appear in the illustration.
- QUANTITY PER ASSEMBLY. This column lists the number of parts used in each assembly. For sub-assemblies and piece parts at the 2nd indenture, the number given refers to the number of parts used in each sub-assembly. For example, if there are 2 filter wheel assemblies in the FFA, and 3 snap rings used in each wheel assembly, the listing will look like this:

INDEX NO.	PART NUMBER	DESCRIPTION						QUAN PER ASSY	USABLE ON CODE
		1	2	3	4	5	6		
30		.						2	
31		.	.					3	
32		.	.					2	
33		.	.					2	A
		.	.					2	B
34		.	.					2	
35		.	.					2	
36		.	.					2	
37	MD-9606-016	.	.					2	

- USABLE ON CODE. The following codes have been established:
 - A This is a preferred part. It replaces obsolete parts when the obsolete part fails.
 - B This is an obsolete part. When it fails, replace it with a preferred part.
 - 2 This part was used in 2nd generation luminaires, serial no. 96061001 thru 96061100.
 - 3 This part was used in 3rd generation luminaires, serial no. 96062001 thru 96062100.
 - 4 This part was used in 4th generation luminaires, serial no. 96063001 thru 96063150.
 - 5 This part was used in 5th generation luminaires, serial no. 96064001 thru 96064033.
 - 6 This part was used in 6th generation luminaires, serial no. 96065001 thru 96065380.
 - E1 This part is used with GE and EMI1 lamp power supplies.
 - E2 This part is used with EMI2 lamp power supplies.

If no code appears, the part is used in all versions of the luminaire.

4-1. HOW TO READ THE PARTS LIST (CONT'D)

Circuit Card Assemblies

Orthographic (plan view) drawings are used to illustrate the location of the electronic components of circuit card assemblies. The parts list which accompanies these illustrations begins with the following heading:

REF	PART NUMBER	DESCRIPTION						QUAN	USABLE
DES		1	2	3	4	5	6	PER	ON
		ASSY	CODE

Parts information given in five columns under the headings is the same as previously described with the following exception:

- o REF DES. This column lists the Reference Designators (Ref Des) assigned to the components listed in the description. The Ref Des appears on or adjacent to the part in the illustration. The Ref Des also appears in chapter 3 on the schematic diagram of the circuit card assembly.

4-2. HOW TO USE THE CROSS REFERENCE INDEX

The part number to manufacturer cross reference index is organized in Vari-Lite part number order, and gives the manufacturer and manufacturer's part number for each Vari-Lite part. The first two digits in the Vari-Lite part number signify a family into which like parts are grouped. The remaining digits will, in some cases, convey some information about the part encoded in the part number. The part number families are grouped as follows:

<u>FAMILY</u>	<u>DESCRIPTION</u>
00 - 09	DOCUMENTS
10 - 19	ENGINEERING DRAWINGS
20 - 39	MECHANICAL ASSEMBLY
40 - 49	MECHANICAL COMPONENTS
50 - 59	HARDWARE
60 - 79	DISCRETE COMPONENTS
80 - 89	SEMICONDUCTORS
90 - 99	UNDEFINED

VARI*LITE
02-3002-0002

Section II. ILLUSTRATED PARTS LIST

4-3. HEAD ASSEMBLY

INDEX NO.	PART NUMBER	DESCRIPTION 1 2 3 4 5 6	QUAN	USABLE
			PER ASSY	ON CODE
	21-9606-0002	HEAD ASSY	REF	
1	10-9606-0041	. BODY COVER, Upper.....	1	
2	53-6607-0001	. SCREW 6-32x1/4 PPB (AP).	6	
3	22-9606-0009	. IRIS BULKHEAD ASSY.....	1	
4	53-6558-0001	. SCREW 6-32x3/8 PPZ (AP).	2	
5	22-9606-0003	. FILTER/FOCAL ASSY.....	1	
6	53-6558-0001	. SCREW 6-32x3/8 PPZ (AP).	4	
7	10-9606-0018	. SHROUD CAP.....	2	
8	53-2002-0001	. NUT, Hex 6-32 keps (AP).	4	
9	10-9606-0034	. BAFFLE, Upper.....	1	
10	70-3718-0001	. FUSE, Thermal 100 deg C.	1	
	52-8279-0001	. SPLICE, #16-22 butt (AP)	1	
11	53-6609-0001	. SCREW 6-32x3/8 PFZ (AP).	2	
	52-6267-0002	. CONNECTOR, Female 3-pin.	1	
	52-8201-0001	. TERMINAL, Tin pin 16AWG.	2	
12	10-9606-0023	. PLATE, Rear end.....	1	
13	10-9606-0057	. PLATE, Rear striker.....	1	
14	53-6608-0001	. SCREW 6-32x3/8 PFB (AP).	2	
15	71-2503-0001	. LAMP, MARC 350.....	1	
16	10-9606-0056	. BAFFLE ASSY, Rear access	1	
17	53-6543-0001	. SCREW 6-32x3/8 PPB (AP).	2	
18	10-9606-0064	. FILTER, Air.....	1	
19	10-9606-0042	. BODY COVER, Lower.....	1	
20	53-6607-0001	. SCREW 6-32x1/4 PPB (AP).	6	
21	22-9606-0031	. HEAD FAN ASSY.....	1	
22	53-6558-0001	. SCREW 6-32x3/8 PPZ (AP).	4	
23	10-9606-0032	. BAFFLE EXTENSION.....	1	
24	53-6558-0001	. SCREW 6-32x3/8 PPZ (AP).	2	
25	24-9606-0038	. CIRCUIT CARD ASSY.....	1	
		Wheel servo board		
26	53-6558-0001	. SCREW 6-32x3/8 PPZ (AP).	4	
27	10-9606-0022	. PLATE, Front end.....	1	
28	53-6543-0001	. SCREW 6-32x3/8 PPB (AP).	4	
29	55-2223-0001	. WINDOW, Float glass.....	1	
		3x3x1/8"		
30	22-9606-0020	. TILT BRACKET ASSY.....	1	
	53-6609-0001	. SCREW 6-32x3/8 PFZ (AP).	2	
31	54-1220-0002	. SPROCKET, 48T 1/5"Px....	1	
		5/16"B		
32	53-6634-0001	. SCREW, Allen 3/8-16x1/2.	1	
33		. TILT STOP.....	1	
	55-6575-0001	. . SCREW 10-32x3/8 PPB...	1	
	55-6584-0001	. . SPACER, 3/8"RND #10 ..	1	
		x5/8" BLK		
	53-2001-0001	. . NUT, Hex 10-32 keps...	1	

VARI*LITE
02-3002-0002

4-3. HEAD ASSEMBLY (CONT'D)

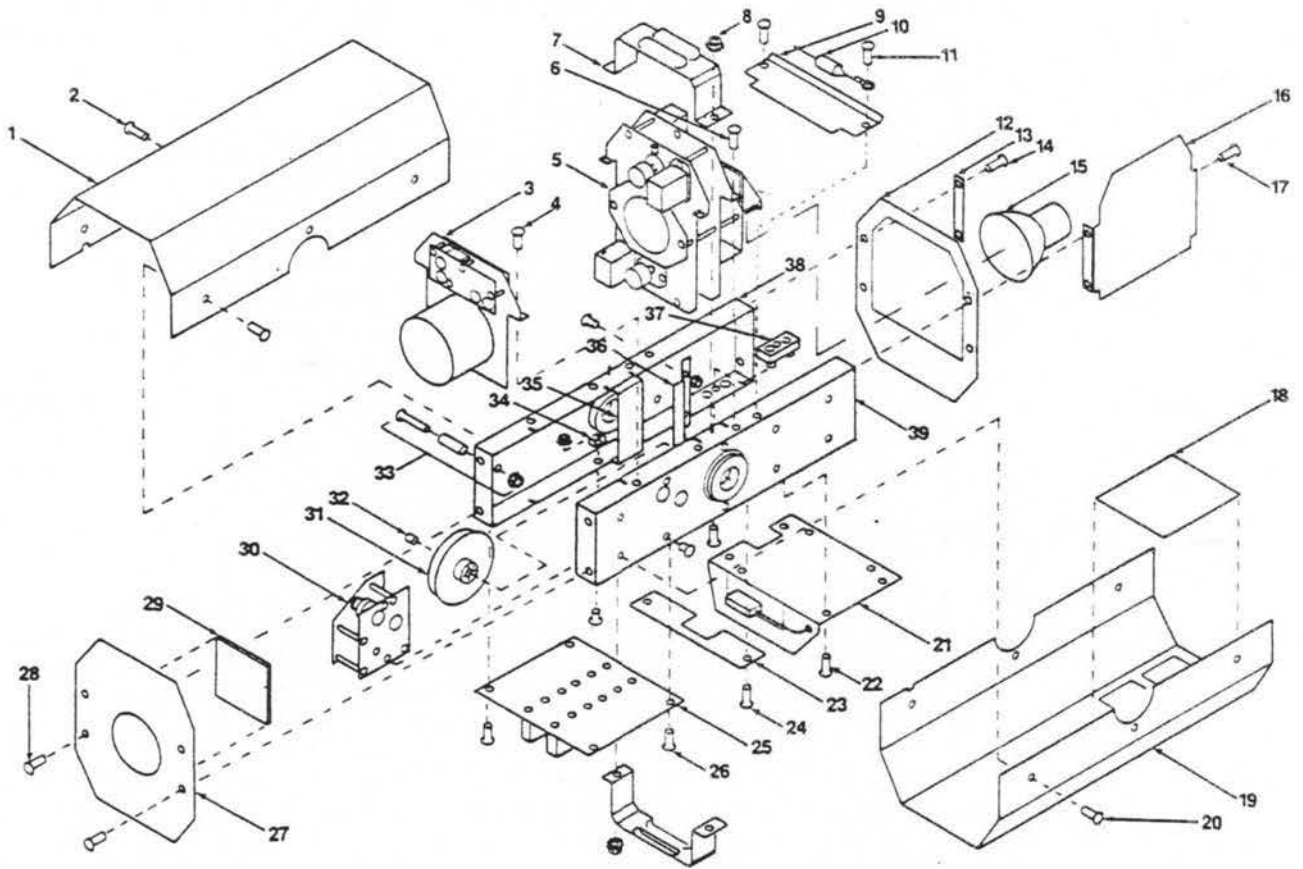

INDEX NO.	PART NUMBER	DESCRIPTION						QUAN PER ASSY	USABLE ON CODE
		1	2	3	4	5	6		
34	55-2179-0002	.	SADDLE, Ty-wrap.....					1	
	53-6525-0001	.	SCREW 6-32x5/16 PPZ (AP)					1	
	53-2002-0001	.	NUT, Hex 6-32 keps (AP).					1	
	55-2186-0001	.	TY-WRAP.....					1	
35	10-9606-0019	.	SHROUD, Center.....					2	
36	10-9606-0033	.	HEAT SHEILD.....					2	
	53-6559-0001	.	SCREW 4-40x1/4 PFZ (AP).					4	
	53-2003-0001	.	NUT, Hex 4-40 keps (AP).					4	
37	71-2517-0001	.	CONNECTOR, Lamp.....					1	
	53-6545-0002	.	SCREW, Thread-cutting... #8x3/8" (AP)					1	
38	10-9606-0037	.	SIDE RAIL, Right.....					1	
39	10-9606-0036	.	SIDE RAIL, Left.....					1	

VARI*LITE
02-3002-0002

4-4. YOKE ASSEMBLY

INDEX NO.	PART NUMBER	DESCRIPTION						QUAN	USABLE
		1	2	3	4	5	6	PER ASSY	ON CODE
	22-9606-0046	YOKE ASSY						REF	
	25-9606-0001	. CABLE ASSY, VL1 yoke.....						1	
1	52-6244-0001	. . CONNECTOR, IDC 6-pin....						2	
2	52-6358-0001	. . CONNECTOR, IDC 3-pin....						2	
3	52-6270-0001	. . CONNECTOR, IDC 5-pin....						2	
4	73-7048-0001	. . CABLE, 20-conductor.....						9'	
5	52-8280-0001	. . LUG, Ground.....						2	
6	52-6267-0001	. . CONNECTOR, Male 3-pin...						1	
7	52-8205-0001	. . TERMINAL, Tin socket....						2	
		16AWG							
8	52-6267-0002	. . CONNECTOR, Female 3-pin.						1	
9	52-8202-0001	. . TERMINAL, Tin pin 16AWG.						3	
	25-9606-0002	. CABLE ASSY, Lamp.....						1	
10	52-6267-0001	. . CONNECTOR, Male 3-pin...						1	
11	52-8205-0001	. . TERMINAL, Tin socket....						2	
		16AWG							
12	73-7066-0001	. . CABLE, HV lamp, black...						6'	
13	73-7066-0002	. . CABLE, HV lamp, red.....						6'	
14	52-6267-0002	. . CONNECTOR, Female 3-pin.						1	
15	52-8202-0001	. . TERMINAL, Tin pin 16AWG.						2	
16	54-1201-0002	. BUSHING, Anti-chafing...						1	
		7/8" OD							
17	55-2179-0002	. SADDLE, Ty-wrap.....						4	
	53-6524-0002	. SCREW 6-32x5/16 PPB (AP)						4	
	53-2002-0001	. NUT, Hex 6-32 keps (AP).						4	
	55-2186-0001	. TY-WRAP.....						4	
18	10-9606-0046	. YOKE.....						1	
19		. PAN STOP.....						1	
	55-6575-0001	. . SCREW 10-32x3/8 PPB...						1	
	55-6584-0001	. . SPACER, 3/8"RND #10 ..						1	
		x5/8" BLK							
	53-2001-0001	. . NUT, Hex 10-32 keps...						1	
20	55-6568-0007	. SPRING, Buffer, lamp....						1	
		1/4" dia.							
21	54-1220-0002	. SPROCKET, 48T 1/5"Px....						1	
		5/16"B							
22	53-6634-0001	. SCREW, Allen 3/8-16x1/2.						1	
23	55-6568-0006	. SPRING, Buffer, signal..						1	
		3/8" dia.							

VARI*LITE
02-3002-0002

4-4. YOKE ASSEMBLY (CONT'D)

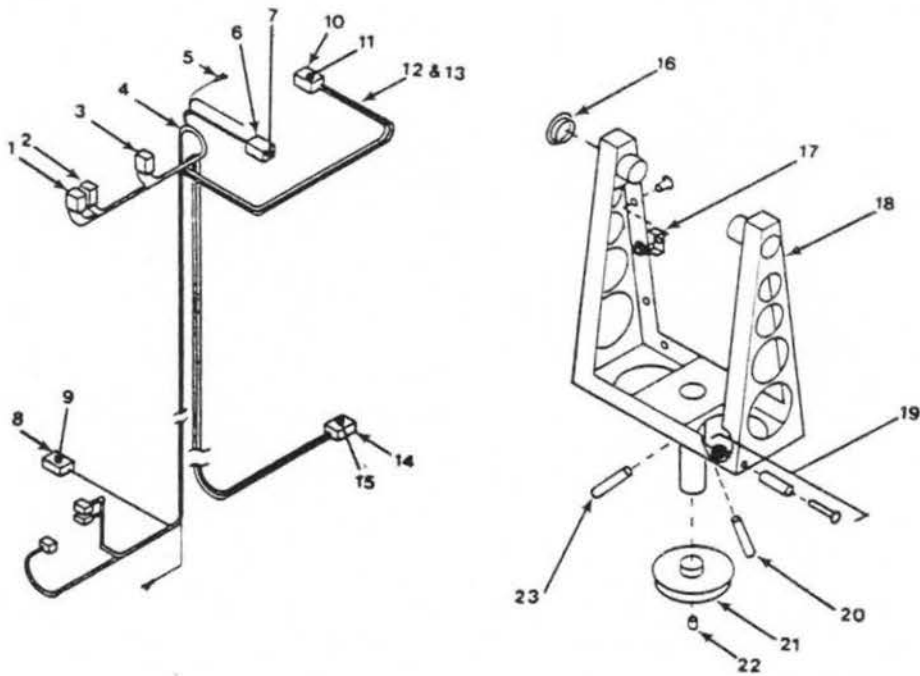

VARI*LITE
02-3002-0002

4-5. UPPER ENCLOSURE

INDEX NO.	PART NUMBER	DESCRIPTION						QUAN PER ASSY	USABLE ON CODE
		1	2	3	4	5	6		
	21-9606-0052	UPPER ENCLOSURE.....						REF	
1	ref	. BRACKET ASSY, PCB.....						1	
		(see pg 4-10)							
2	68-4526-0001	. TRANSFORMER.....						1	4-6
	53-6545-0001	. . SCREW 8-32x3/8 PPB (AP).						4	4-6
	53-2004-0001	. . NUT, Hex 8-32 keps (AP).						4	4-6
3	62-2084-0123	. CAPACITOR, Filter.....						2	
		12000UF/30V electro							
4	82-4301-9802	. RECTIFIER, Bridge.....						2	
	53-6544-0001	. . SCREW 8-32x3/4 PPB (AP).						2	
	53-2004-0001	. . NUT, Hex 8-32 keps (AP).						2	
5	62-2085-0153	. CAPACITOR, Filter.....						1	
		15000UF/15V electro							
	55-2187-0003	. . CLAMP, Capacitor (AP)...						3	
	53-6543-0001	. . SCREW 6-32x3/8 PPB (AP).						6	
	53-2002-0001	. . NUT, Hex 6-32 keps (AP).						6	
	52-8230-0002	. TERMINAL, Faston 1/4".....						12	
		. TERMINAL, Faston 3/16".....						12	
		. TERMINAL, Faston 3/16".....						2	
		doubler							
6	40-7107-0001	. FAN, Axial blower.....						1	
7	55-2222-0002	. SCREEN 1/8x4x4.....						1	
	53-6612-0001	. . SCREW 6-32x1/2 PPB (AP).						3	
	53-2002-0001	. . NUT, Hex 6-32 keps (AP).						3	
8	66-4508-0002	. RELAY, Solid-state.....						1	
	53-6520-0001	. . SCREW 4-40x3/8 PPZ (AP).						2	
	53-2003-0001	. . NUT, Hex 4-40 keps (AP).						2	
9	69-3101-0002	. LAMP POWER SUPPLY.....						1	6
	53-6623-0001	. . SCREW 10-32x3/8 PFB (AP)						4	
	55-6657-0001	. . STANDOFF 1/2"RND						4	
		10-32x1"							
	53-6517-0001	. . SCREW 10-32x3/8 PPZ (AP)						4	
10	24-9606-0059	. CIRCUIT CARD ASSY.....						1	
		LPS control board							
	53-6543-0001	. . SCREW 6-32x3/8 PPB (AP).						2	
	55-6538-0001	. . WASHER, #6 lock (AP)....						2	
	55-6658-0001	. . STANDOFF (AP).....						2	
		1/4"hex 6-32x5/16							
	53-2002-0001	. . NUT, Hex 6-32 keps (AP).						2	
11	55-2222-0003	. GRILLE 1/8x8x12.....						1	
12	55-6510-0002	. GROMMET, Continuous.....						1	
13	22-9606-0020	. PAN/TILT ASSY.....						1	
	53-2002-0001	. . NUT, Hex 6-32 keps (AP).						2	
14	53-6623-0001	. SCREW 10-32x3/8 PFB						5	
15	74-1010-0001	. SWITCH, Thumbwheel.....						1	
		2-digit BCD							
16	70-3714-0002	. HOLDER, Fuse HTA-DD.....						2	
17	70-3717-0001	. FUSE, 1.5A SLO-BLO						1	

VARI*LITE
02-3002-0002

4-5. UPPER ENCLOSURE (CONT'D)

INDEX NO.	PART NUMBER	DESCRIPTION						QUAN PER ASSY	USABLE ON CODE
		1	2	3	4	5	6		
18	70-3701-0001	.						1	
19	52-6251-0001	.						1	
	53-6551-0001	.	.					4	
	53-2003-0001	.	.					4	
	52-8205-0001	.	.					2	
	52-8210-0001	.	.					3	
20	43-1001-0001	.						1	
	53-6520-0001	.	.					3	
	53-2003-0001	.	.					3	
21	10-9606-0052	.						1	
22	54-1221-0001	.						6	
23	55-2187-0002	.						1	
	53-2004-0001	.	.					2	
24	55-2179-0002	.						2	
24	55-2186-0001	.						15	

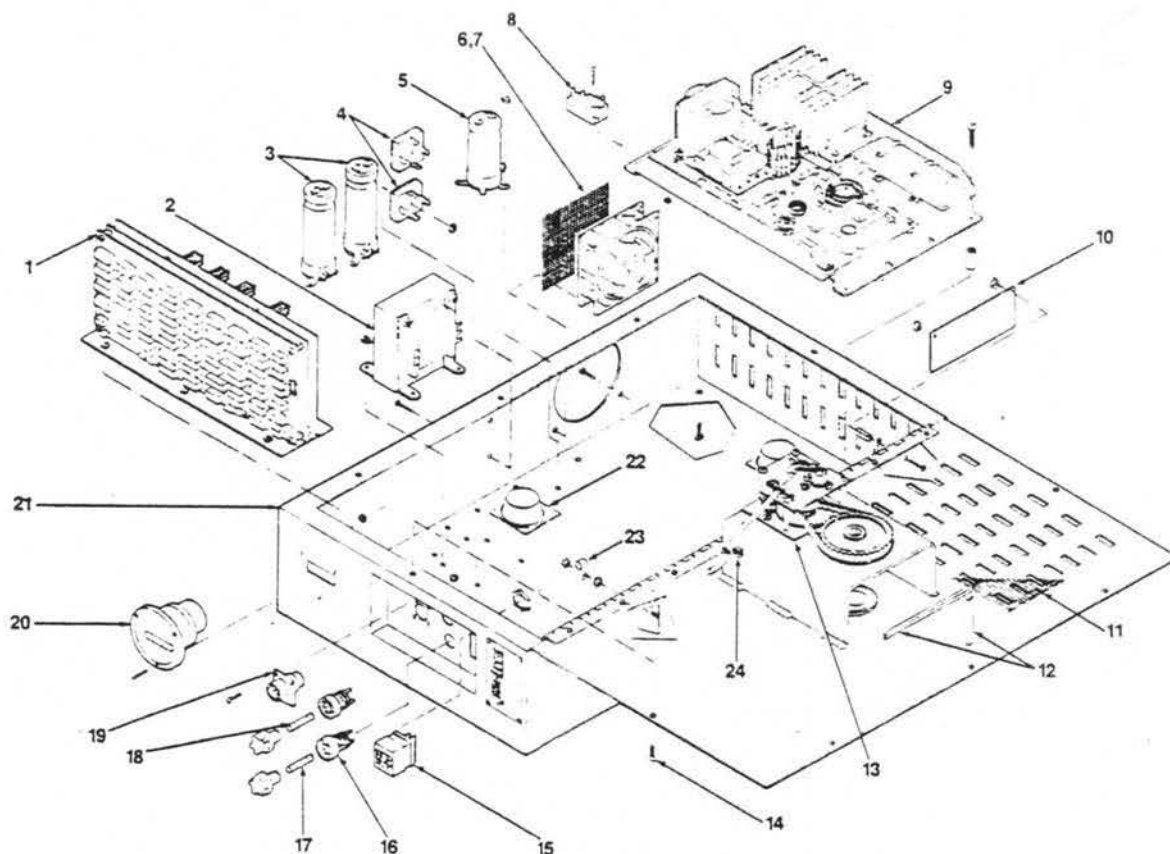

VARI*LITE
02-3002-0002

4-5. UPPER ENCLOSURE (CONT'D)

INDEX NO.	PART NUMBER	DESCRIPTION						QUAN	USABLE
		1	2	3	4	5	6	PER ASSY	ON CODE
	ref	.						1	
25	24-9606-0011	.	.					1	
26	24-9606-0063	.	.					1	
27	10-9606-0061	.	.					1	
28	10-9606-0054	.	.					1	
29	55-6658-0002	.	.					10	
30	55-6538-0001	.	.					20	
31	53-6558-0001	.	.					20	
	53-6543-0001	.	.					6	

VARI*LITE
02-3002-0002

4-5. UPPER ENCLOSURE (CONT'D)

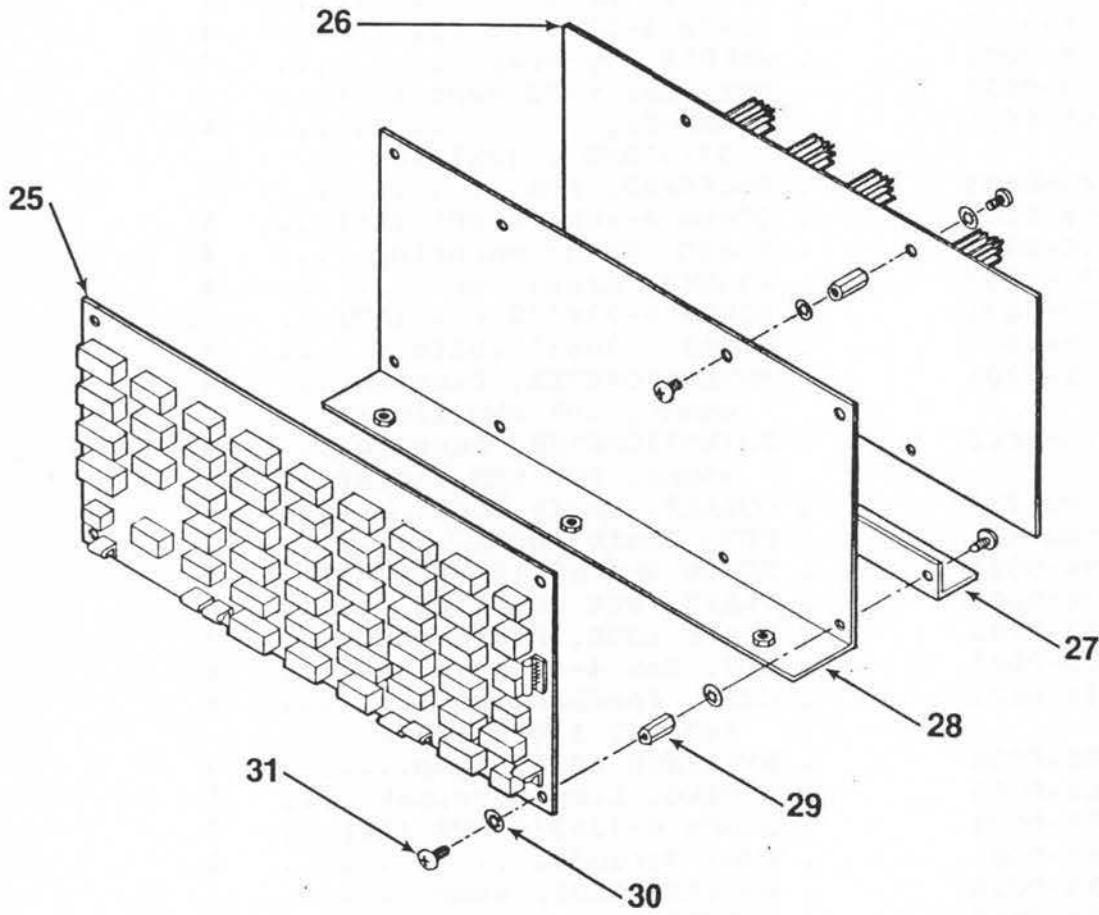

VARI*LITE
02-3002-0002

4-6. FILTER/FOCAL ASSEMBLY

INDEX NO.	PART NUMBER	DESCRIPTION						QUAN PER ASSY	USABLE ON CODE
		1	2	3	4	5	6		
	22-9606-0003	FILTER/FOCAL ASSY						REF	
1	53-6558-0001	. SCREW 6-32x3/8 PPZ (AP)...						2	
2	10-9606-0017	. RETAINER, Lens						1	
3	55-6654-0002	. STANDOFF.....						2	
		1/4"hex 6-32x3/16 MF							
4	42-5001-0001	. LENS, Aspheric						1	
5	10-9606-0067	. SPACER, Lens						1	
6	53-6525-0001	. SCREW 6-32x5/16 PPZ (AP)..						4	
7	55-2179-0002	. SADDLE, Ty-wrap.....						4	
8	53-2002-0001	. NUT, Hex 6-32 keps (AP)...						4	
9	55-6660-0001	. STANDOFF,						6	
		5/16"RND 6-32x7/16							
10	10-9606-0003	. BULKHEAD, FFA						2	
11	53-6559-0001	. SCREW 4-40x1/4 PFZ (AP)...						8	
12	10-9606-0070	. PLATE, Motor mounting.....						4	
13	55-6517-0001	. WASHER, Brass, #6						4	
14	53-6558-0001	. SCREW 6-32x3/8 PPZ (AP)...						12	
15	44-5015-0001	. MOTOR, .9063" shaft.....						4	
16	63-2009-0001	. POTENTIOMETER, Bushing....						4	A
		mount, 10k ohm linear							
	63-2019-0002	. POTENTIOMETER, Bushing....						4	B
		mount, 10k ohm linear							
17	see item 21	. COLLET, Shaft lock.....						4	
18	see item 21	. NUT, Shaft lock.....						4	
19	53-6596-0001	. SCREW 4-40x5/16 PPZ (AP)..						8	
20	10-9606-0005	. PLATE, Pot mounting.....						4	
21	54-1213-0003	. SHAFT LOCK, Plate mount...						4	
22	53-2003-0001	. NUT, Hex 4-40 keps (AP)...						8	
23	54-1214-0001	. GEAR, Feedback pot.....						4	
		64P 96T 1/8"B 1/8"F							
24	22-9606-0030	. RETAINER ASSY, Lamp.....						1	
25	55-6568-0005	. SPRING, Lamp retainer.....						2	
26	53-6558-0001	. SCREW 6-32x3/8 PPZ (AP)...						2	
27	52-8280-0001	. LUG, Ground.....						2	
28	10-9606-0028	. BRACKET ASSY, Lamp.....						1	
29	55-6654-0001	. STANDOFF,						2	
		1/4"HEX 6-32x11/16 MF							
30	ref	. FILTER WHEEL ASSY.....						2	
31	54-1222-0001	. . SNAP RING.....						3	
32	55-6545-0001	. . BEARING, Bronze thrust..						2	
33	10-9606-0081	. . WASHER, Silicone rubber.						2	A
		. . WASHER, Neoprene.....						2	B
34	54-1201-0003	. . BEARING, Bronze.....						2	
35	55-6568-0008	. . FINGER SPRING.....						2	
36	54-1214-0009	. . HUB GEAR.....						2	
		64P 64T 1/2"B 3/16"F							

VARI*LITE
02-3002-0002

4-6. FILTER/FOCAL ASSEMBLY (CONT'D)

INDEX NO.	PART NUMBER	DESCRIPTION						QUAN PER ASSY	USABLE ON CODE
		1	2	3	4	5	6		
37	10-9606-0016	2	
38	55-6546-0001	1	
39	10-9606-0073	1	
40		1	
41		1	
42	54-1206-0003	3	

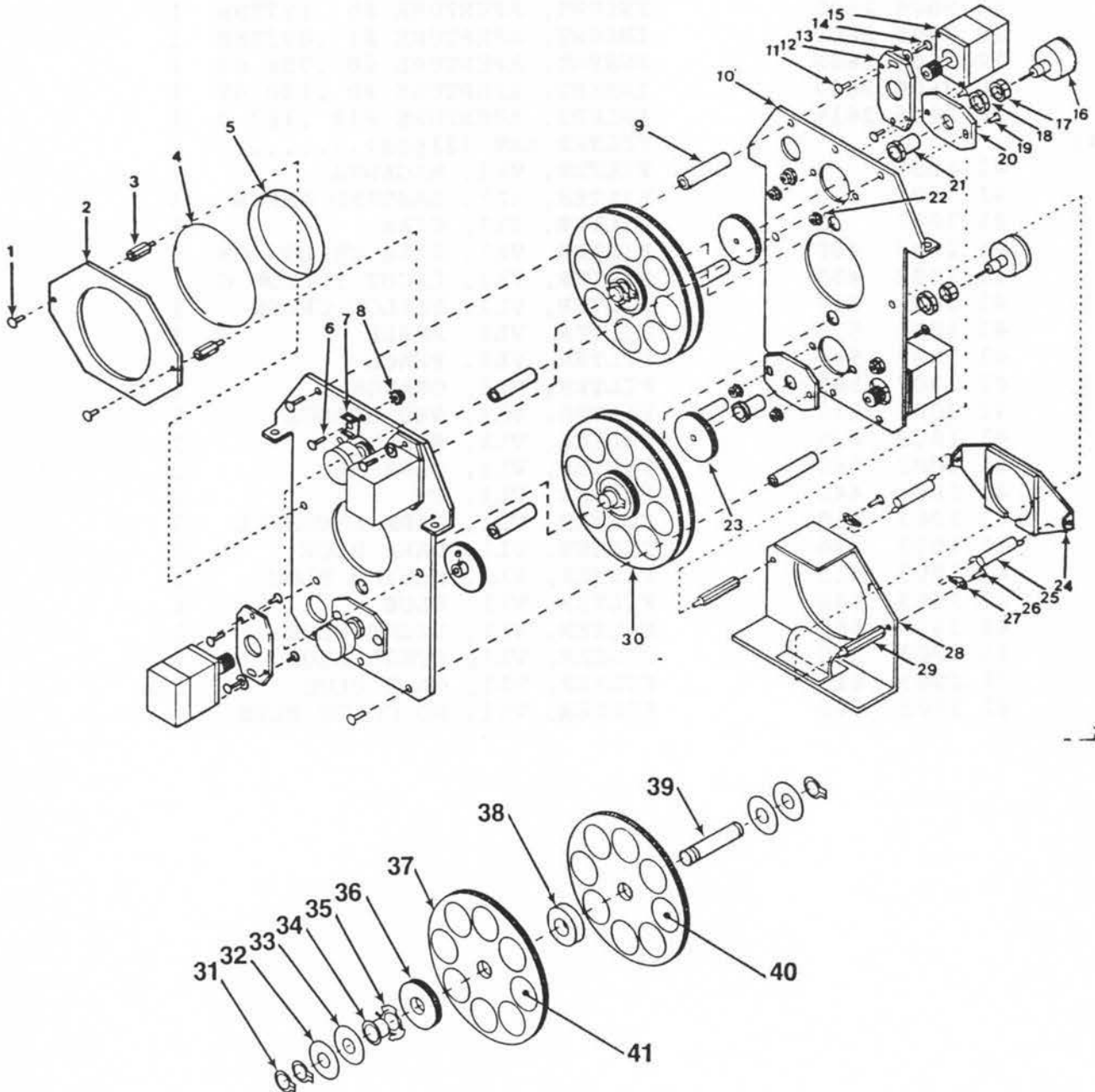

VARI*LITE
02-3002-0002

4-6. FILTER/FOCAL ASSEMBLY (CONT'D)

Filters, Apertures, Gobos

INDEX NO.	PART NUMBER	DESCRIPTION	1 2 3 4 5 6						QUAN PER ASSY	USABLE ON CODE
				
40		. APERTURE SET (7pcs).....							1	
	10 9606 2601	INSERT, APERTURE #1 .703 TH							1	
	10 9606 2602	INSERT, APERTURE #2 .500THR							1	
	10 9606 2603	INSERT, APERTURE #3 .406THR							1	
	10 9606 2604	INSERT, APERTURE #4 .296THR							1	
	10 9606 2605	INSERT, APERTURE #5 .187THR							1	
	10 9606 2607	INSERT, APERTURE #7 .093THR							1	
	10 9606 2608	INSERT, APERTURE #8 .75X.06							1	
	10 9606 2609	INSERT, APERTURE #9 .140 OT							1	
	10 9606 2610	INSERT, APERTURE #10 .187 0							1	
41		. FILTER SET (21pcs).....							1	
	41 1001 1	FILTER, VL1, MAGENTA							1	
	41 1001 2	FILTER, VL1, BASTARD AMBER							1	
	41 1001 3	FILTER, VL1, CYAN							1	
	41 1002 460	FILTER, VL1, PALE YELLOW GR							1	
	41 1002 485	FILTER, VL1, LIGHT YELLOW G							1	
	41 1002 510	FILTER, VL1, YELLOW GREEN							1	
	41 1002 535	FILTER, VL1, AMBER							1	
	41 1002 560	FILTER, VL1, PEACH							1	
	41 1002 585	FILTER, VL1, ORANGE							1	
	41 1002 610	FILTER, VL1, RED ORANGE							1	
	41 1002 635	FILTER, VL1, RED							1	
	41 1002 660	FILTER, VL1, DARK RED							1	
	41 1003 440	FILTER, VL1, UV							1	
	41 1003 465	FILTER, VL1, DARK LAVENDER							1	
	41 1003 490	FILTER, VL1, DARK BLUE							1	
	41 1003 515	FILTER, VL1, MEDIUM BLUE							1	
	41 1003 540	FILTER, VL1, BLUE							1	
	41 1003 565	FILTER, VL1, LIGHT BLUE							1	
	41 1003 590	FILTER, VL1, STEEL BLUE							1	
	41 1003 615	FILTER, VL1, PALE BLUE							1	
	41 1003 640	FILTER, VL1, NO COLOR BLUE							1	

4-6. FILTER/FOCAL ASSEMBLY (CONT'D)

Filters, Apertures, Gobos (cont'd)

6TH GENERATION

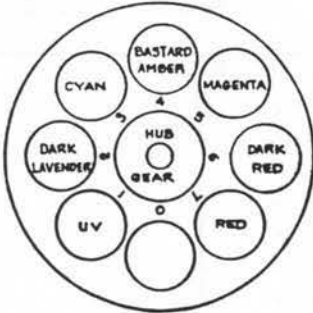

#1 (COATED SIDE UP)

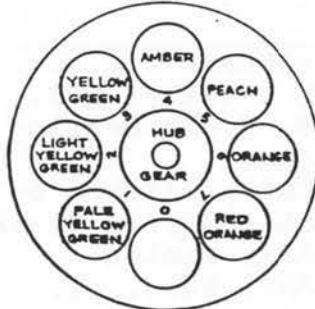

#2

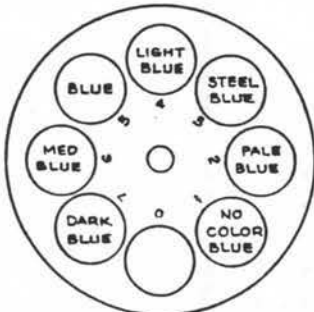

#3 (COATED SIDE UP)

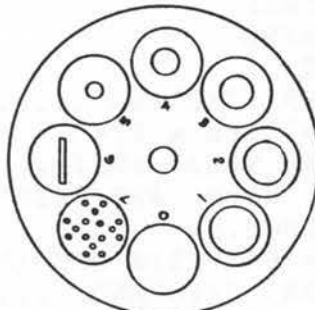

#4 (SHINY SIDE DOWN)

1ST THRU 5TH GENERATION

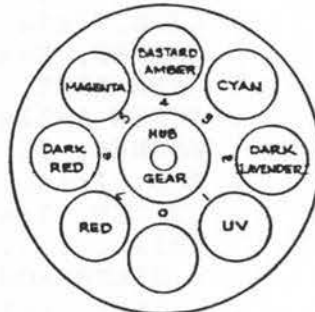

#1 (COATED SIDE UP)

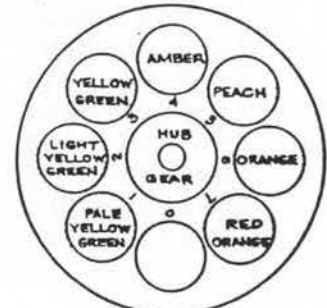

#2

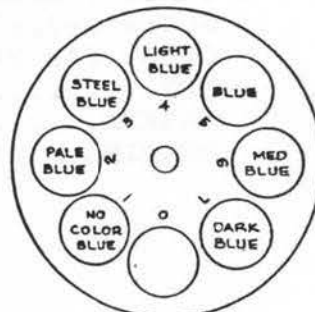

#3 (COATED SIDE UP)

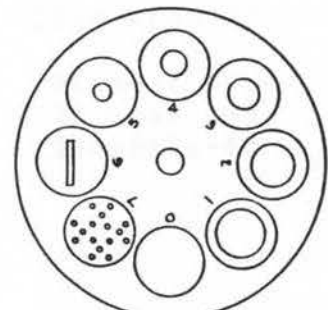

#4 (SHINY SIDE DOWN)

VARI*LITE
02-3002-0002

4-7. IRIS BULKHEAD

INDEX NO.	PART NUMBER	DESCRIPTION						QUAN PER ASSY	USABLE ON CODE
		1	2	3	4	5	6		
	22-9606-0009	IRIS BULKHEAD.....						REF	
1	53-6558-0001	. SCREW 6-32x3/8 PPZ.....						4	
2	10-9606-1007	. PLATE, Front bearing						1	
		support							
3	55-6654-0003	. STANDOFF, 1/4"rnd 6-32x1..						4	
	54-1216-0001	. CLUTCH ASSY, 50 02-In.....						1	
4	10-9606-1008	. . SHAFT, Pinion.....						1	
5	54-1215-0001	. . CLAMP, Hub.....						1	
6		. . HUB.....						1	
7	54-1214-0004	. . GEAR, Delrin worm 48P50T						1	
8		. . WASHER						1	
9		. . SPRING						1	
10		. . NUT						2	
11	55-6655-0001	. SPACER, 3/8"RND						1	
		1/4"thru x 1/4"							
12	44-5015-0001	. MOTOR, 9063" shaft.....						1	
13	54-1214-0006	. GEAR, Worm, 48P 3/16".....						1	
		BRHWOS.S.							
14	53-6558-0001	. SCREW 6-32x3/8 PPZ (AP)...						1	
15	55-6655-0003	. SPACER, 5/16"RND						3	
		#6 x 5/16"							
16	10-9606-2007	. PLATE, Rear bearing.....						1	
		support							
17	53-6616-0001	. SCREW 6-32x3/4 PPZ (AP)...						2	
18	10-9606-0082	. LINK, Iris arm.....						1	
19	54-1218-0001	. COLLAR, Set screw.....						1	
20	10-9606-0024	. GEAR ASSY, Iris arm.....						1	
21	53-6616-0001	. SCREW 6-32x3/4 PPZ (AP)...						4	
22	55-6517-0001	. WASHER, #6 flat.....						5	
23	10-9606-0039	. POD, Iris.....						1	
24	55-6655-0002	. SPACER, 1/4"RND #6 x 5/16.						4	
	54-1217-0002	. IRIS.....						1	
25		. . DIAPHRAGM, Outer.....						1	
26		. . LEAF, Iris.....						18	
27		. . DIAPHRAGM, Inner.....						1	
28		. . CLIP, Retaining.....						1	
29	53-6616-0001	. SCREW 6-32x3/4 PPZ (AP)...						1	
30		. GEAR, 64P 24T 1/8"B 1/8"F.						1	
31	see item 36	. NUT.....						1	
32	see item 36	. WASHER.....						1	
33	54-1208-0001	. BEARING, 1/4"ID, 1/2"OD...						2	

VARI*LITE
02-3002-0002

4-7. IRIS BULKHEAD (CONT'D)

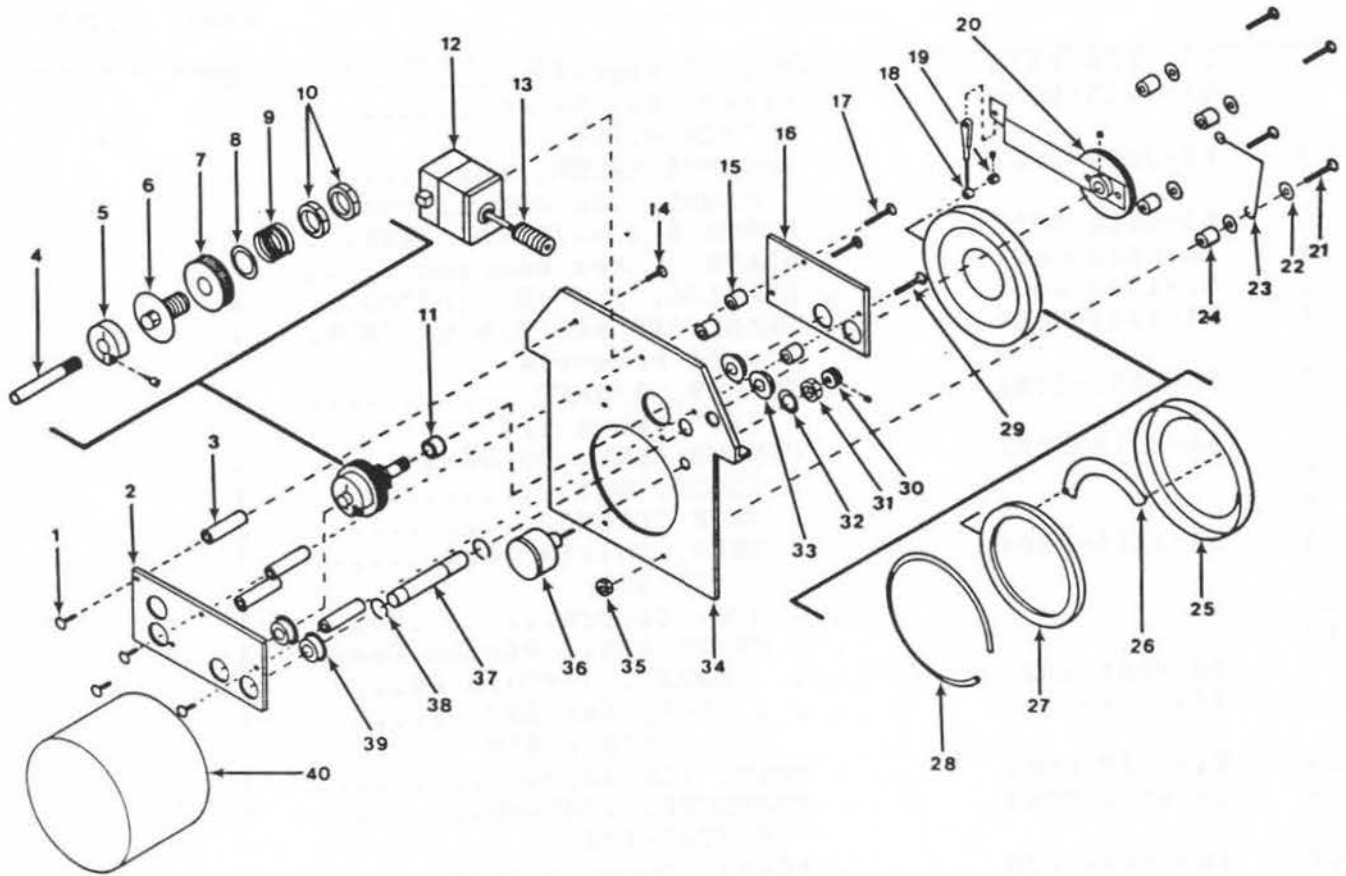

INDEX NO.	PART NUMBER	DESCRIPTION						QUAN PER ASSY	USABLE ON CODE
		1	2	3	4	5	6		
34	10-9606-0009	1	
35	53-2002-0001	4	
36	63-2009-0001	1	A
	63-2019-0002	1	B
37	10-9606-0008	1	
38	54-1217-0003	2	
39	54-1208-0001	2	
40	10-9606-0066	1	

VARI*LITE
02-3002-0002

4-8. PAN/TILT BRACKET

INDEX NO.	PART NUMBER	DESCRIPTION	QUAN	USABLE
			PER ASSY	ON CODE
	22-9606-0020	PAN/TILT BRACKET.....	REF	
1	54-1215-0002	. CLAMP, Synchro G..... "DIM"=.250	2	
2	63-2009-0001	. POTENTIOMETER, servo..... mount, 10k ohm linear	1	
3	53-6558-0001	. SCREW 6-32x3/8 PPZ (AP)...	5	
4	10-9606-0021	. PLATE, Outer bearing.....	1	
5	54-1208-0001	. BEARING, 1/4"ID, 1/2"OD...	4	
6	54-1214-0001	. GEAR, 64P 96T 1/8"B 1/8"F. w/#4 setscrew	1	
7	55-6655-0001	. SPACER, 3/8RND 1/4"thru x 1/4"	1	
	54-1216-0002	. CLUTCH ASSY, 50 oz-in	1	
8		. . CLAMP, Hub.....	1	
9		. . WAVE SPRING.....	2	
10	54-1214-0004	. . GEAR, Delrin worm..... 48P 50T	1	
11		. . HUB, Clutch.....	1	
12		. . SHAFT ASSY, Pinion Gear.	1	
	10-9606-1021	. . . SHAFT, 1/4"dia SS.....	1	
	54-1214-0008	. . . GEAR, 64P 30T..... 1/4"B 1/8"T	1	
13	54-1219-0001	. BELT, 120 pitch.....	1	
15	55-6658-0003	. STANDOFF, 1/4"RND..... 6-32x1-1/4	5	
17	10-9606-2020	. PLATE, Inner bearing.....	1	
16	53-6609-0001	. SCREW 6-32x3/8 PFZ (AP)...	5	
18		. SPROCKET/GEAR ASSY.....	1	
	54-1217-0003	. . CIRCLIP, 1/4"dia.....	1	
	54-1220-0001	. . SPROCKET, 14T..... 1/5"P x 1/4"B	1	
	54-1214-0007	. . GEAR, 64P 120T..... 1/4"B 1/8"F	1	
	10-9606-1021	. . SHAFT, Pinion 14T 64P...	1	
19		. MOTOR/GEAR ASSY.....	1	
	54-1214-0006	. . GEAR, Worm, 48P 3/16"...	1	
	44-5015-0001	. . MOTOR, .9063 shaft.....	1	

VARI*LITE
02-3002-0002

4-8. PAN/TILT BRACKET (CONT'D)

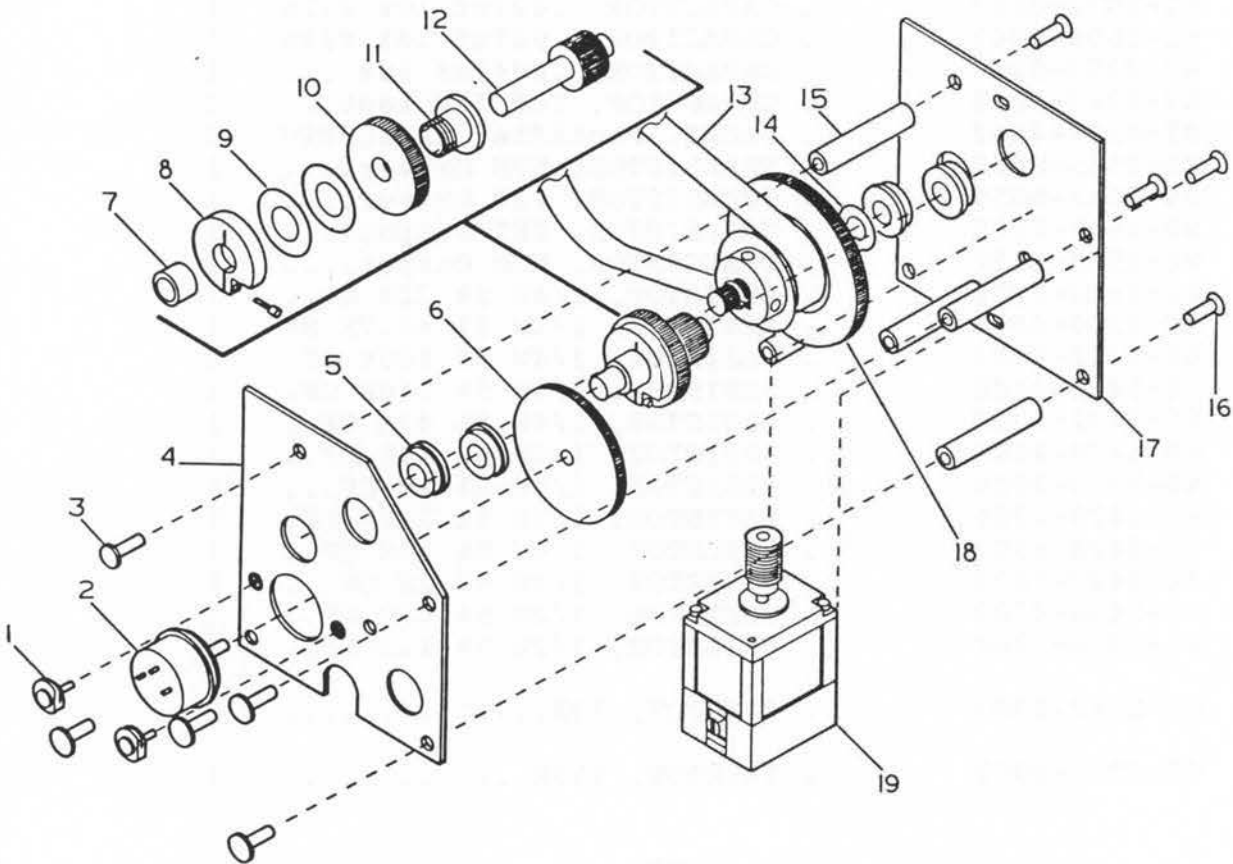

VARI*LITE
02-3002-0002

4-9. CIRCUIT CARD ASSEMBLY, WHEEL SERVO BOARD

Wheel Servo Circuit 1, 3

REF DES	PART NUMBER	DESCRIPTION						QUAN PER ASSY	USABLE ON CODE
		1	2	3	4	5	6		
		SERVO CIRCUIT, Wheel 1, 3...						2	
A1/A2	83-3108-0001	. INTEGRATED CIRCUIT, Dual.. Operational Amplifier						1	
C1	62-2005-0001	. CAPACITOR, .01uf 10% film.						1	
C2	62-2071-0027	. CAPACITOR, .027uf 10% film						1	
C3	62-2009-0047	. CAPACITOR, .047uf 10% film						1	
C4	62-2053-0047	. CAPACITOR, .0047uf 10% ...						1	
C5,C6	62-2042-0105	. CAPACITOR, 1uf 35V tant...						2	
D1-D4	82-4307-4002	. DIODE, Rectifier 1A 100PIV						4	
Q1	80-2513-0005	. TRANSISTOR, NPN Driver....						1	
Q2	80-2513-0055	. TRANSISTOR, PNP Driver....						1	
Q3	80-1513-6125	. TRANSISTOR, PNP Output....						1	
Q4	80-1512-6122	. TRANSISTOR, NPN Output....						1	
R1	60-1422-2202	. RESISTOR, 1/4W 5% 22K CF..						1	
R2	60-1230-4874	. RESISTOR, 1/4W 1% 48.7K MF						1	
R3,R4	60-1426-1003	. RESISTOR, 1/4W 5% 100K CF.						2	
R5	60-1421-9105	. RESISTOR, 1/4W 5% 910K CF.						1	
R6	60-1421-4702	. RESISTOR, 1/4W 5% 47K CF..						1	
R7	60-1424-1005	. RESISTOR, 1/4W 5% 10K CF..						1	
R8	60-1423-1004	. RESISTOR, 1/4W 5% 1M CF...						1	
R9	60-1420-2204	. RESISTOR, 1/4W 5% 2.2K CF.						1	
R10	60-1424-1502	. RESISTOR, 1/4W 5% 15K CF..						1	
R11	60-1422-1001	. RESISTOR, 1/4W 5% 1K CF...						1	
R12	60-2424-4702	. RESISTOR, 1/2W 5% 470 CF..						1	
R13, -R14	60-2410-1200	. RESISTOR, 1/2W 5% 1.2 CF..						2	
TR1, -TR2	63-2012-0001	. TRIMPOT, 10K.....						2	
TR3	63-2011-0001	. TRIMPOT, 250K.....						1	

NOTE

The servo circuit for wheels 1 and 3 are identical in layout and components used.

VARI*LITE
02-3002-0002

4-9. CIRCUIT CARD ASSEMBLY, WHEEL SERVO BOARD (CONT'D)

Wheel Servo Circuit 1, 3 (cont'd)

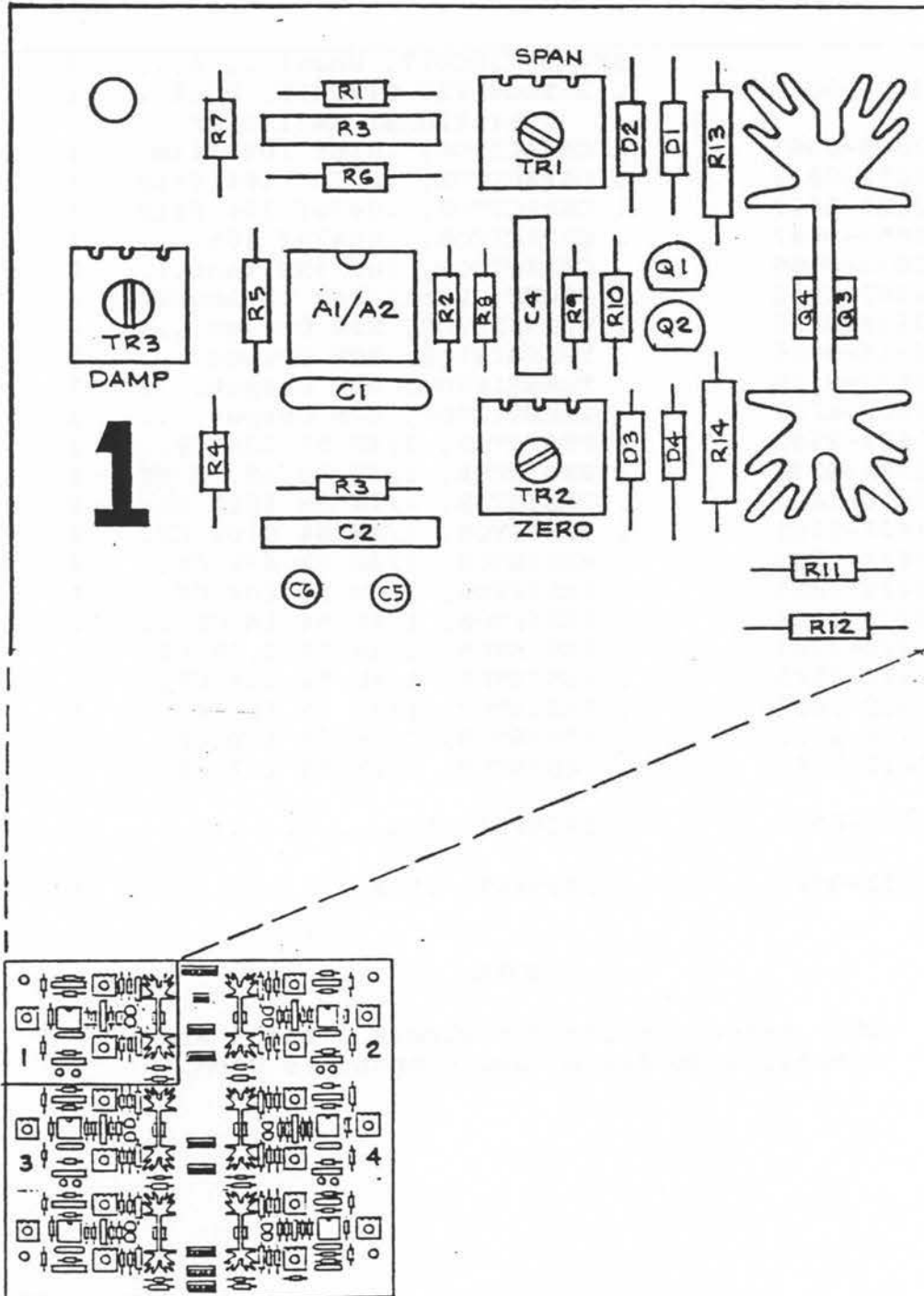

VARI*LITE
02-3002-0002

4-9. CIRCUIT CARD ASSEMBLY, WHEEL SERVO BOARD (CONT'D)

Wheel Servo Circuit 2, 4

REF DES	PART NUMBER	DESCRIPTION						QUAN PER ASSY	USABLE ON CODE
		1	2	3	4	5	6		
		SERVO CIRCUIT, Wheel 2, 4...						2	
A1/A2	83-3108-0001	. INTEGRATED CIRCUIT, Dual..						1	
		Operational Amplifier							
C1	62-2005-0001	. CAPACITOR, .01uf 10% film.						1	
C2	62-2071-0027	. CAPACITOR, .027uf 10% film						1	
C3	62-2009-0047	. CAPACITOR, .047uf 10% film						1	
C4	62-2053-0047	. CAPACITOR, .0047uf 10% ...						1	
C5,C6	62-2042-0105	. CAPACITOR, 1uf 35V tant...						2	
D1-D4	82-4307-4002	. DIODE, Rectifier 1A 100PIV						4	
Q1	80-2513-0005	. TRANSISTOR, NPN Driver....						1	
Q2	80-2513-0055	. TRANSISTOR, PNP Driver....						1	
Q3	80-1513-6125	. TRANSISTOR, PNP Output....						1	
Q4	80-1512-6122	. TRANSISTOR, NPN Output....						1	
R1	60-1422-2202	. RESISTOR, 1/4W 5% 22K CF..						1	
R2	60-1230-4874	. RESISTOR, 1/4W 1% 48.7K MF						1	
R3,R4	60-1426-1003	. RESISTOR, 1/4W 5% 100K CF.						2	
R5	60-1421-9105	. RESISTOR, 1/4W 5% 910K CF.						1	
R6	60-1421-4702	. RESISTOR, 1/4W 5% 47K CF..						1	
R7	60-1424-1005	. RESISTOR, 1/4W 5% 10K CF..						1	
R8	60-1423-1004	. RESISTOR, 1/4W 5% 1M CF...						1	
R9	60-1420-2204	. RESISTOR, 1/4W 5% 2.2K CF.						1	
R10	60-1424-1502	. RESISTOR, 1/4W 5% 15K CF..						1	
R11	60-1422-1001	. RESISTOR, 1/4W 5% 1K CF...						1	
R12	60-2424-4702	. RESISTOR, 1/2W 5% 470 CF..						1	
R13, -R14	60-2410-1200	. RESISTOR, 1/2W 5% 1.2 CF..						2	
TR1, -TR2	63-2012-0001	. TRIMPOT, 10K.....						2	
TR3	63-2011-0001	. TRIMPOT, 250K.....						1	

NOTE

The servo circuit for wheels 2 and 4 are identical in layout and components used.

VARI*LITE
02-3002-0002

4-9. CIRCUIT CARD ASSEMBLY, WHEEL SERVO BOARD (CONT'D)

Wheel Servo Circuit 2, 4 (cont'd)

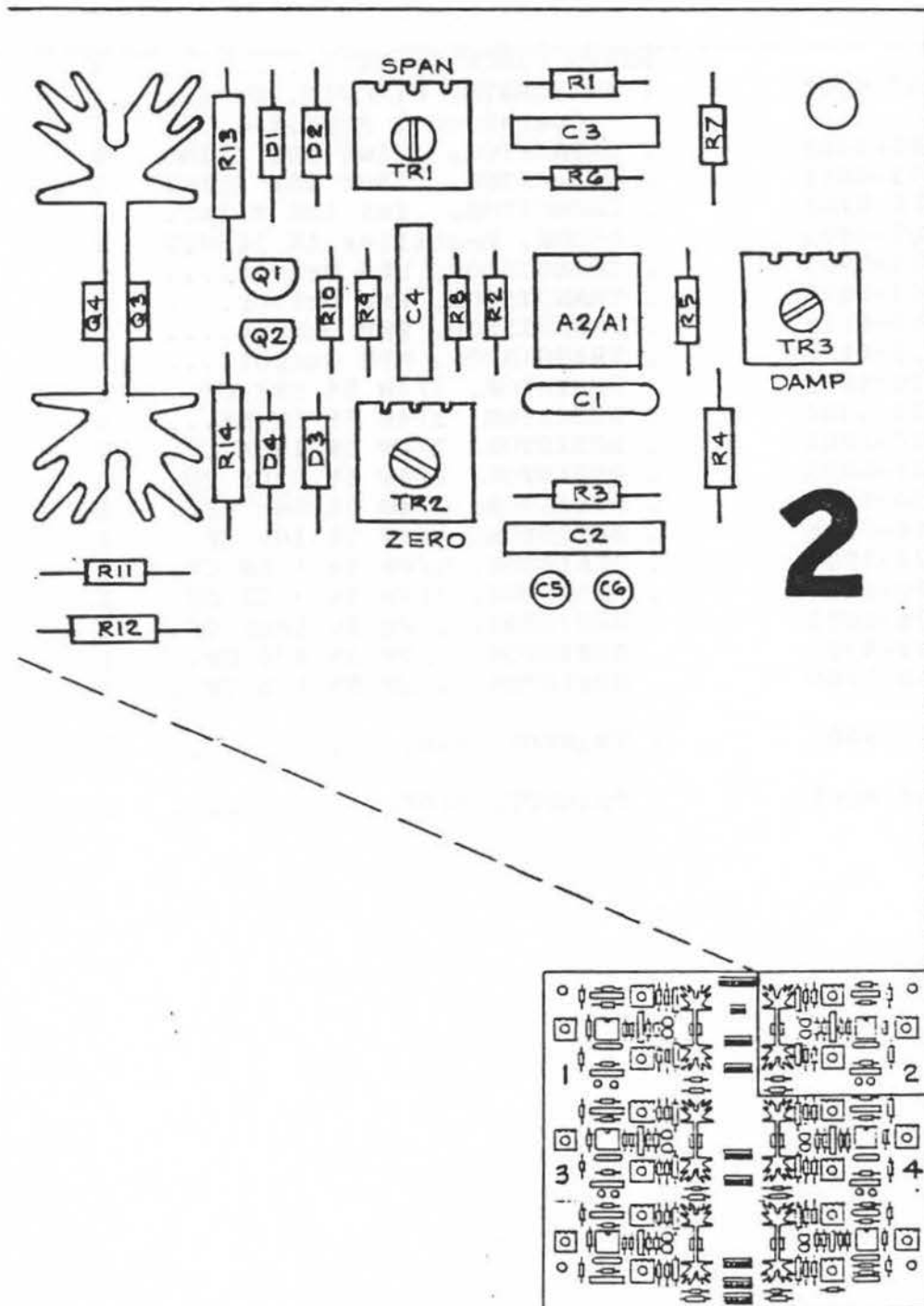

VARI*LITE
02-3002-0002

4-9. CIRCUIT CARD ASSEMBLY, WHEEL SERVO BOARD (CONT'D)

Tilt Servo Circuit

REF DES	PART NUMBER	DESCRIPTION						QUAN PER ASSY	USABLE ON CODE
		1	2	3	4	5	6		
			
A1/A2	83-3108-0001	SERVO CIRCUIT, Tilt						1	
		. INTEGRATED CIRCUIT, Dual..						1	
		Operational Amplifier							
C1	62-2005-0001	. CAPACITOR, .01uf 10% film.						1	
C2	62-2073-0015	. CAPACITOR, .15uf 10% film.						1	
C3,C4	62-2016-0104	. CAPACITOR, .1uf 10% film..						2	
D1-D4	82-4307-4002	. DIODE, Rectifier 1A 100PIV						4	
Q1	80-2513-0005	. TRANSISTOR, NPN Driver....						1	
Q2	80-2513-0055	. TRANSISTOR, PNP Driver....						1	
Q3	80-1513-6125	. TRANSISTOR, PNP Output....						1	
Q4	80-1512-6122	. TRANSISTOR, NPN Output....						1	
R1	60-1430-5602	. RESISTOR, 1/4W 5% 56K CF..						1	
R2	60-1423-1004	. RESISTOR, 1/4W 5% 1M MF...						1	
R3,R4	60-1426-1003	. RESISTOR, 1/4W 5% 100K CF.						2	
R5	60-1421-6805	. RESISTOR, 1/4W 5% 680K CF.						1	
R6	60-1430-5602	. RESISTOR, 1/4W 5% 56K CF..						1	
R7	60-1424-1005	. RESISTOR, 1/4W 5% 10K CF..						1	
R8	60-1429-1506	. RESISTOR, 1/4W 5% 1.5M CF.						1	
R9,11	60-1420-2204	. RESISTOR, 1/4W 5% 2.2K CF.						2	
R10	60-1426-1003	. RESISTOR, 1/4W 5% 100K CF.						1	
R12	60-2424-4702	. RESISTOR, 1/2W 5% 470 CF..						1	
R13, -R14	60-2410-1200	. RESISTOR, 1/2W 5% 1.5 CF..						2	
TR1, -TR2	63-2012-0001	. TRIMPOT, 10K.....						2	
TR3	63-2015-0001	. TRIMPOT, 500K.....						1	

4-9. CIRCUIT CARD ASSEMBLY, WHEEL SERVO BOARD (CONT'D)

Tilt Servo Circuit (cont'd)

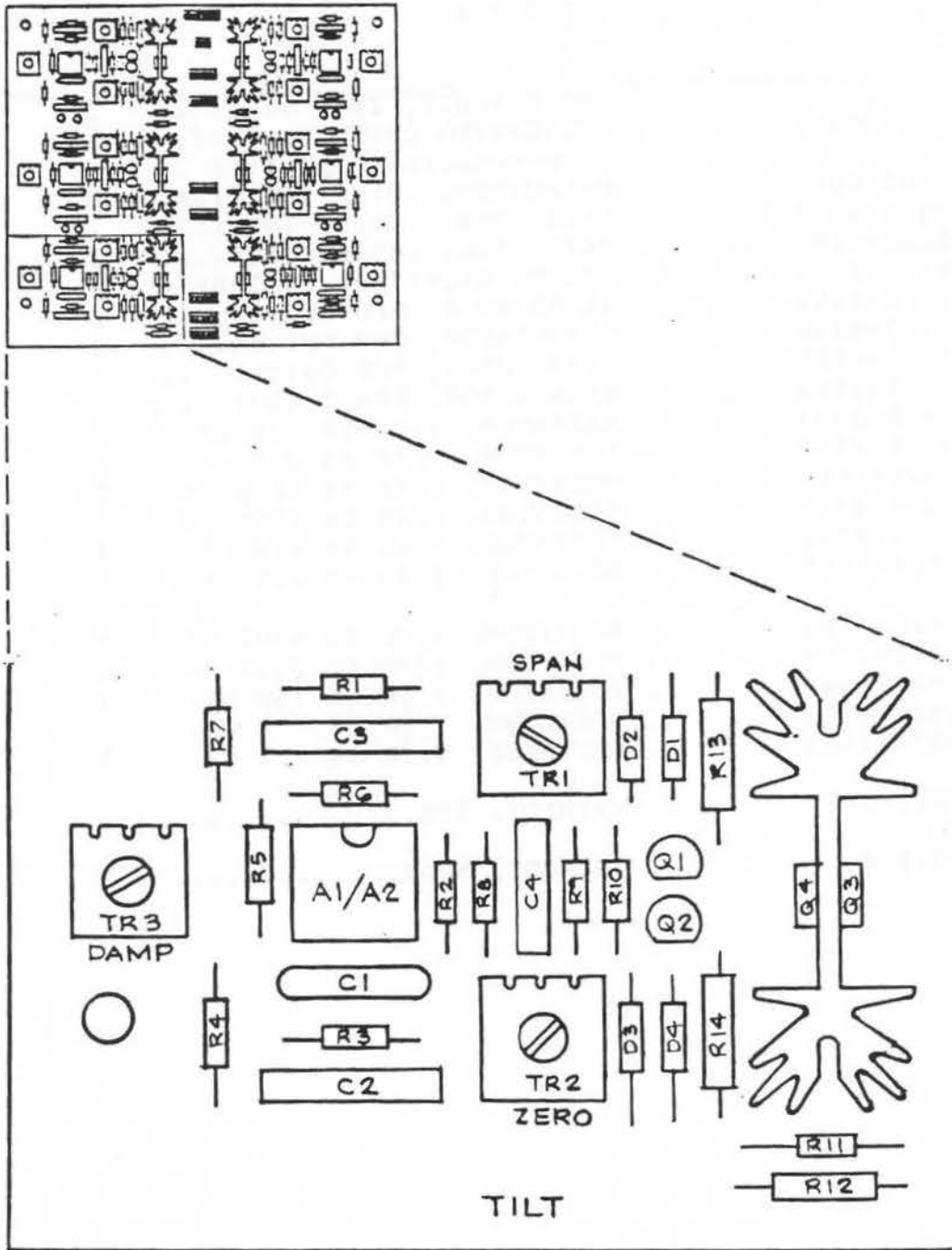

VARI*LITE
02-3002-0002

4-9. CIRCUIT CARD ASSEMBLY, WHEEL SERVO BOARD (CONT'D)

Iris Servo Circuit

REF DES	PART NUMBER	DESCRIPTION						QUAN PER ASSY	USABLE ON CODE
		1	2	3	4	5	6		
			
A2/A1	83-3108-0001	SERVO CIRCUIT, Iris						1	
		. INTEGRATED CIRCUIT, Dual..						1	
		Operational Amplifier							
C1,C3	62-2005-0001	. CAPACITOR, .01uf 10% film.						2	
C2	62-2086-0333	. CAPACITOR, .033uf 10% film						1	
C4	62-2086-0182	. CAPACITOR, .0018uf 10%....						1	
D1-D4	82-4307-4002	. DIODE, Rectifier 1A 100PIV						4	
Q1	80-2513-0005	. TRANSISTOR, NPN Driver....						1	
Q2	80-2513-0055	. TRANSISTOR, PNP Driver....						1	
Q3	80-1513-6125	. TRANSISTOR, PNP Output....						1	
Q4	80-1512-6122	. TRANSISTOR, NPN Output....						1	
R1	60-1420-3302	. RESISTOR, 1/4W 5% 33K CF..						1	
R2	60-1424-2702	. RESISTOR, 1/4W 5% 27K CF..						1	
R3,R4	60-1426-1003	. RESISTOR, 1/4W 5% 100K CF.						2	
R5	60-1426-4703	. RESISTOR, 1/4W 5% 470K CF.						1	
R6	60-1421-4702	. RESISTOR, 1/4W 5% 47K CF..						1	
R7,	60-1424-1005	. RESISTOR, 1/4W 5% 10K CF..						3	
R15,R16									
R8	60-1426-4703	. RESISTOR, 1/4W 5% 470K CF.						1	
R9,11	60-1420-2204	. RESISTOR, 1/4W 5% 2.2K CF.						2	
R10	60-1424-1502	. RESISTOR, 1/4W 5% 15K CF..						1	
R12	60-2424-4702	. RESISTOR, 1/2W 5% 470 CF..						1	
R13,	60-2432-1504	. RESISTOR, 1/2W 5% 1.5 CF..						2	
-R14									
TR1,	63-2012-0001	. TRIMPOT, 10K.....						2	
-TR2									
TR3	63-2015-0001	. TRIMPOT, 500K.....						1	

VARI*LITE
02-3002-0002

4-9. CIRCUIT CARD ASSEMBLY, WHEEL SERVO BOARD (CONT'D)

Iris Servo Circuit (cont'd)

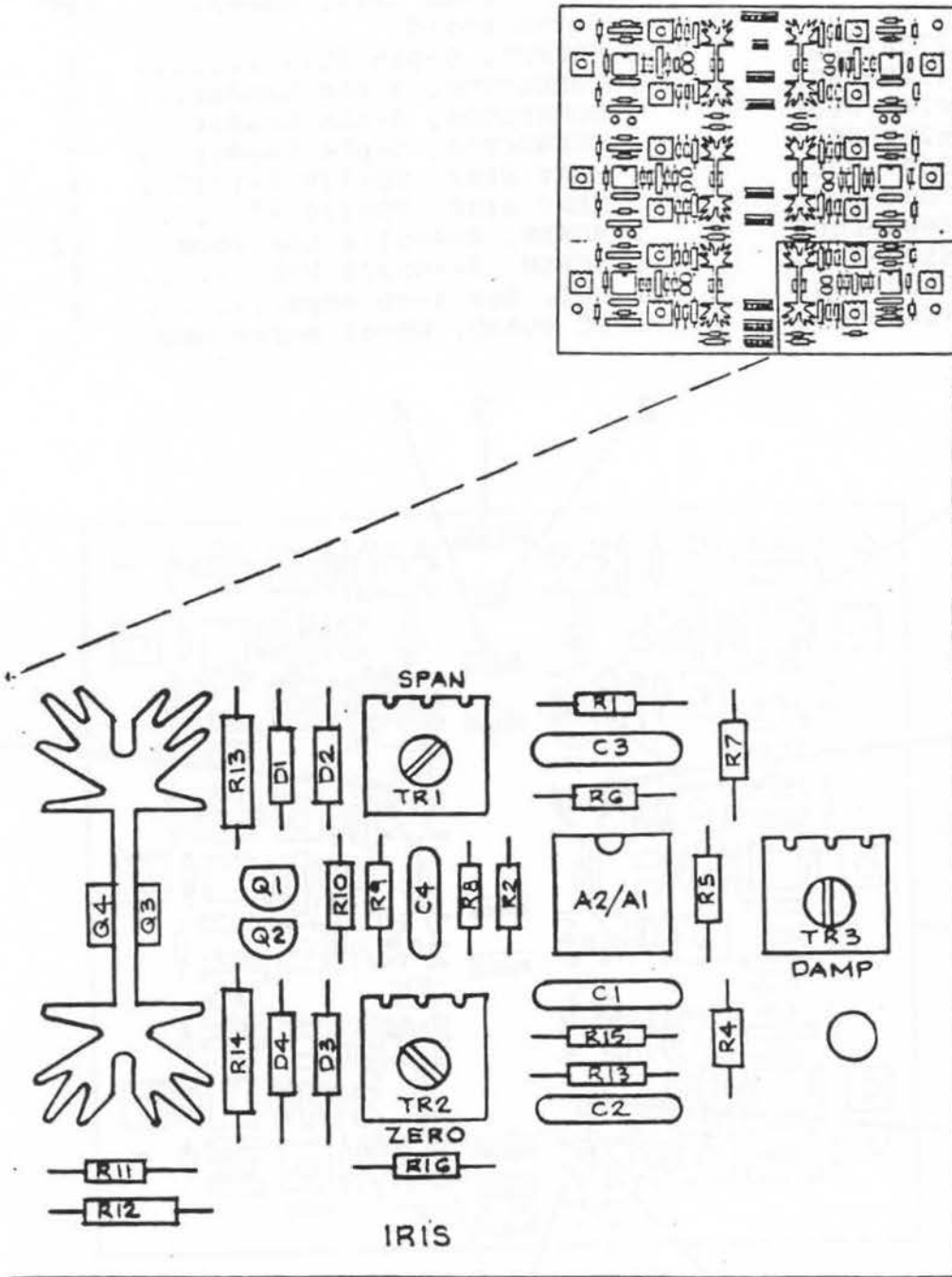

VARI*LITE
02-3002-0002

4-9. CIRCUIT CARD ASSEMBLY, WHEEL SERVO BOARD (CONT'D)

INDEX NO.	PART NUMBER	DESCRIPTION	QUAN		USABLE ON CODE
			PER ASSY	6	
	24-9606-0038	CIRCUIT CARD ASSY, Wheel.... Servo Board	REF		
1	50-2708-0001	. SOCKET, 8-pin IC.....	6		
2	52-6229-0001	. CONNECTOR, 3-pin header...	1		
3	52-6240-0001	. CONNECTOR, 6-pin header...	1		
4	52-6259-0001	. CONNECTOR, 5-pin header...	7		
5	51-5004-0001	. HEAT SINK, TO-220 1-1/2"...	4		
6	51-5004-0002	. HEAT SINK, TO-220 1".....	2		
7	53-6604-0002	. SCREW, 4-40x1/4 thd form..	12		
8	53-6520-0001	. SCREW, 4-40x3/8 PPZ.....	6		
9	53-2003-0001	. NUT, Hex 4-40 keps.....	6		
10	11-9606-0038	. PC BOARD, Wheel servo amp.	1		

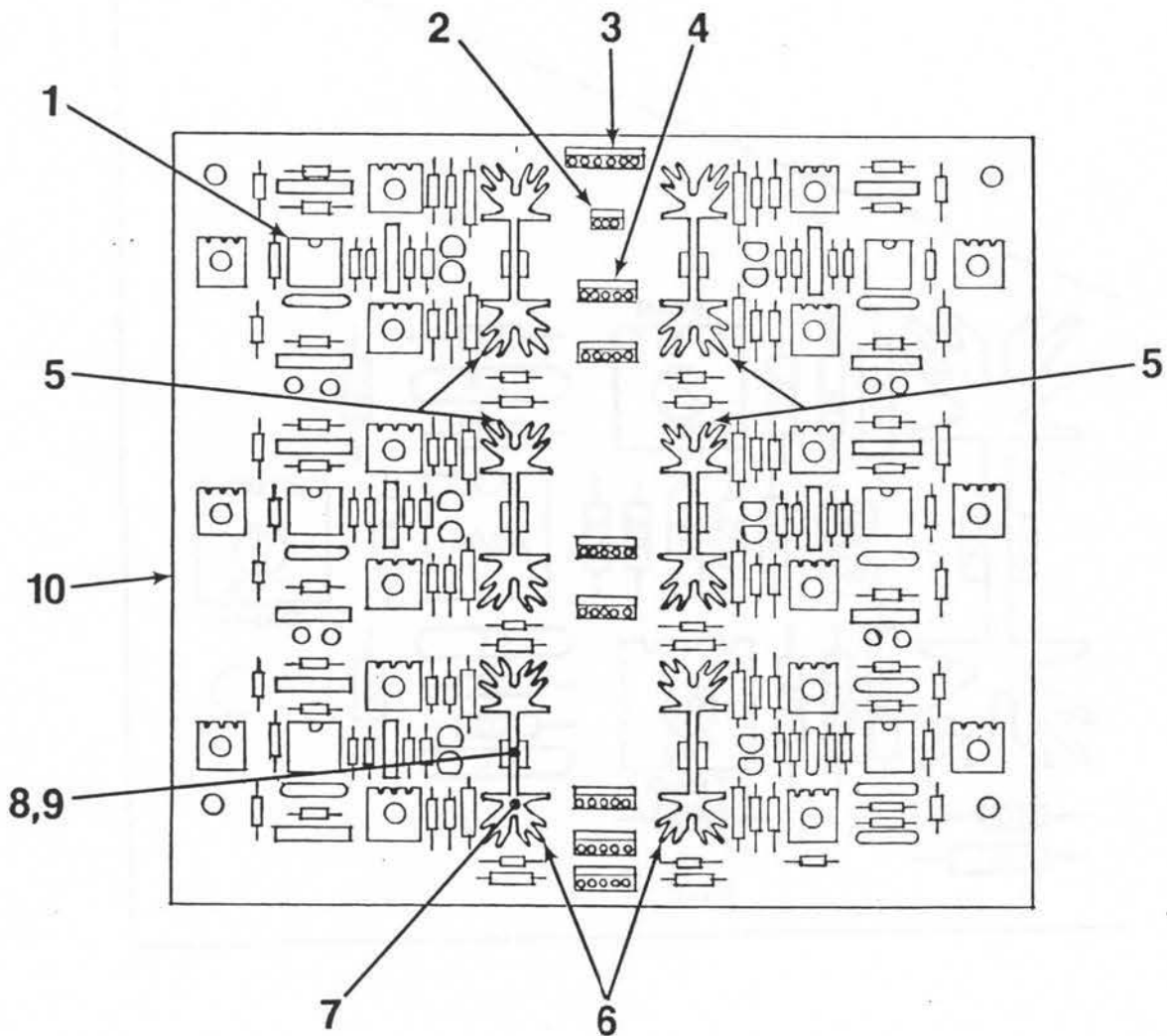

VARI*LITE
02-3002-0002

4-10. HEAD FAN ASSEMBLY

INDEX NO.	PART NUMBER	DESCRIPTION	QUAN	USABLE
			PER ASSY	ON CODE
	22-9606-0031	FAN ASSY, Head.....	REF	
1	55-2222-0001	. CLOTH, Hardware..... 1/4x1x3 inch	1	
2	40-7106-0001	. FAN, Centrifugal blower...	1	
3	53-2011-0002	. NUT, 8-32 small pattern...	3	
4	53-6622-0001	. SCREW, 8-32x1-1/4 PPZ.....	3	
5	52-8201-0001	. TERMINAL, Gold pin 22AWG..	2	
6	52-6267-0002	. CONNECTOR, 3-pin female...	1	
7	55-2120-0001	. GROMMET, Molded.....	1	
8	10-9606-0031	. BAFFLE, Fan mounting.....	1	

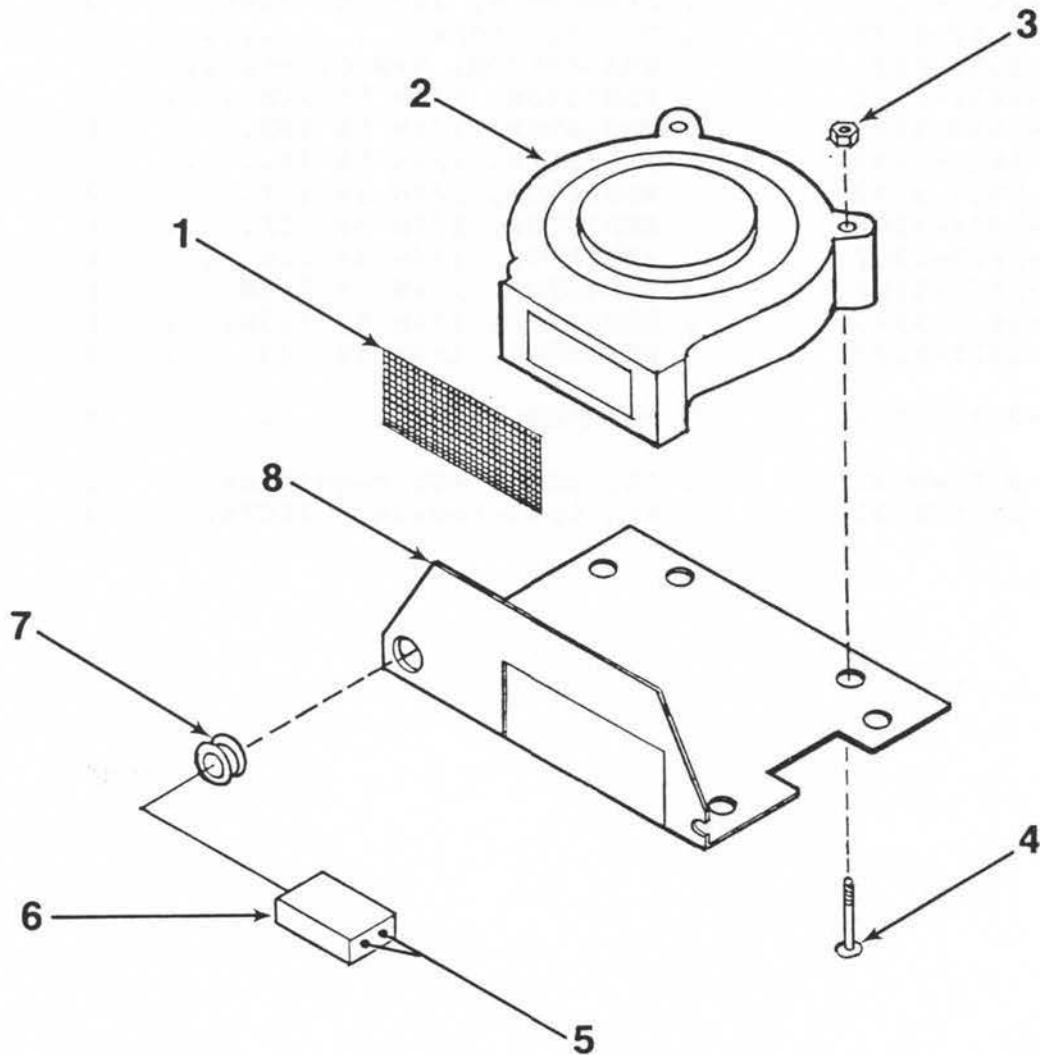

VARI*LITE
02-3002-0002

4-11. CIRCUIT CARD ASSEMBLY, LAMP POWER SUPPLY CONTROL BOARD

INDEX NO.	PART NUMBER	DESCRIPTION						QUAN PER ASSY	USABLE ON CODE
		1	2	3	4	5	6		
	24-9606-0059	CIRCUIT CARD ASSY, LPS Ctrl.						REF	
1	50-2708-0001	. SOCKET, 8-pin IC.....						3	
2	52-6240-0001	. CONNECTOR, 6-pin header...						1	
3	52-6259-0001	. CONNECTOR, 5-pin header...						1	
4	11-9606-0059	. PC BOARD, LPS control.....						1	

REF DES	PART NUMBER	DESCRIPTION						QUAN PER ASSY	USABLE ON CODE
		1	2	3	4	5	6		
C1-C3	62-2042-0105	. CAPACITOR, luf 35V tant...						3	
D1-D3	82-5302-4148	. DIODE, Signal.....						3	
Q1	80-2513-0005	. TRANSISTOR, NPN driver....						1	
R1	60-1422-2202	. RESISTOR, 1/4W 5% 22K.....						1	EMI1
R2	60-1420-1804	. RESISTOR, 1/4W 5% 18K.....						1	EMI1
R3	60-1422-1001	. RESISTOR, 1/4W 5% 1K.....						1	EMI1
R1,R2	60-1427-1202	. RESISTOR, 1/4W 5% 12K.....						2	EMI2
R3	60-1424-1005	. RESISTOR, 1/4W 5% 10K.....						1	EMI2
R4	60-1422-2202	. RESISTOR, 1/4W 5% 22K.....						1	
R5	60-1421-5603	. RESISTOR, 1/4W 5% 5.6K....						1	
R6	60-1422-3903	. RESISTOR, 1/4W 5% 3.9K....						1	
R7-	60-1421-2202	. RESISTOR, 1/4W 5% 220.....						6	
R12									
TR1-	63-2012-0001	. TRIMPOT, 10K.....						4	
TR4									
U1	83-3130-0002	. IC, LM309 +5V regulator...						1	
U2,	86-6101-0001	. IC, Opto-isolator ILCT6...						3	
U3,U4									

VARI*LITE
02-3002-0002

4-11. CIRCUIT CARD ASSEMBLY, LAMP POWER SUPPLY CONTROL BOARD (CONT'D)

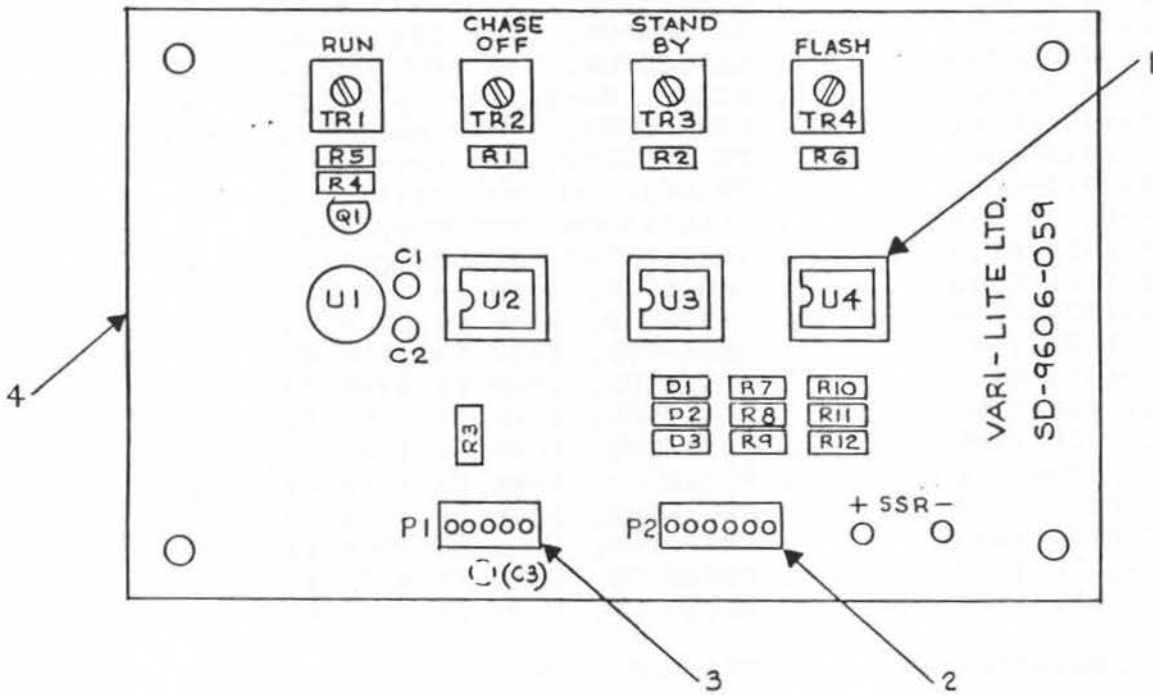

VARI*LITE
02-3002-0002

4-12. CIRCUIT CARD ASSEMBLY, SERVO POWER SUPPLY

Pan Servo Circuit

REF DES	PART NUMBER	DESCRIPTION						QUAN PER ASSY	USABLE ON CODE
		1	2	3	4	5	6		
		SERVO CIRCUIT, Pan.						REF	
A1/A2	83-3108-0001	. INTEGRATED CIRCUIT, Dual..						1	
		Operational Amplifier							
C1	62-2005-0001	. CAPACITOR, .01uf 10% film.						1	
C2	62-2073-0015	. CAPACITOR, .15uf 10% film.						1	
C3,C4	62-2016-0104	. CAPACITOR, .1uf 10% film..						2	
C5,C6	62-2042-0105	. CAPACITOR, 1uf 35V tant...						2	
D1-D4	82-4307-4002	. DIODE, Rectifier 1A 100PIV						4	
P4	52-6259-0001	. CONNECTOR, 5-pin header...						ref	
Q1	80-2513-0005	. TRANSISTOR, NPN Driver....						1	
Q2	80-2513-0055	. TRANSISTOR, PNP Driver....						1	
Q3	80-1513-6125	. TRANSISTOR, PNP Output....						1	
Q4	80-1512-6122	. TRANSISTOR, NPN Output....						1	
R1	60-1430-5602	. RESISTOR, 1/4W 5% 56K CF..						1	
R2	60-1423-1004	. RESISTOR, 1/4W 5% 1M MF...						1	
R3,R4	60-1426-1003	. RESISTOR, 1/4W 5% 100K CF.						2	
R5	60-1421-6805	. RESISTOR, 1/4W 5% 680K CF.						1	
R6	60-1430-5602	. RESISTOR, 1/4W 5% 56K CF..						1	
R7	60-1424-1005	. RESISTOR, 1/4W 5% 10K CF..						1	
R8	60-1429-1506	. RESISTOR, 1/4W 5% 1.5M CF.						1	
R9,11	60-1420-2204	. RESISTOR, 1/4W 5% 2.2K CF.						2	
R10	60-1426-1003	. RESISTOR, 1/4W 5% 100K CF.						1	
R12	60-2424-4702	. RESISTOR, 1/2W 5% 470 CF..						1	
R13,	60-2410-1200	. RESISTOR, 1/2W 5% 1.5 CF..						2	
-R14									
TR1,	63-2012-0001	. TRIMPOT, 10K.....						2	
-TR2									
TR3	63-2015-0001	. TRIMPOT, 500K.....						1	

4-12. CIRCUIT CARD ASSEMBLY, SERVO POWER SUPPLY (CONT'D)

Pan Servo Circuit (cont'd)

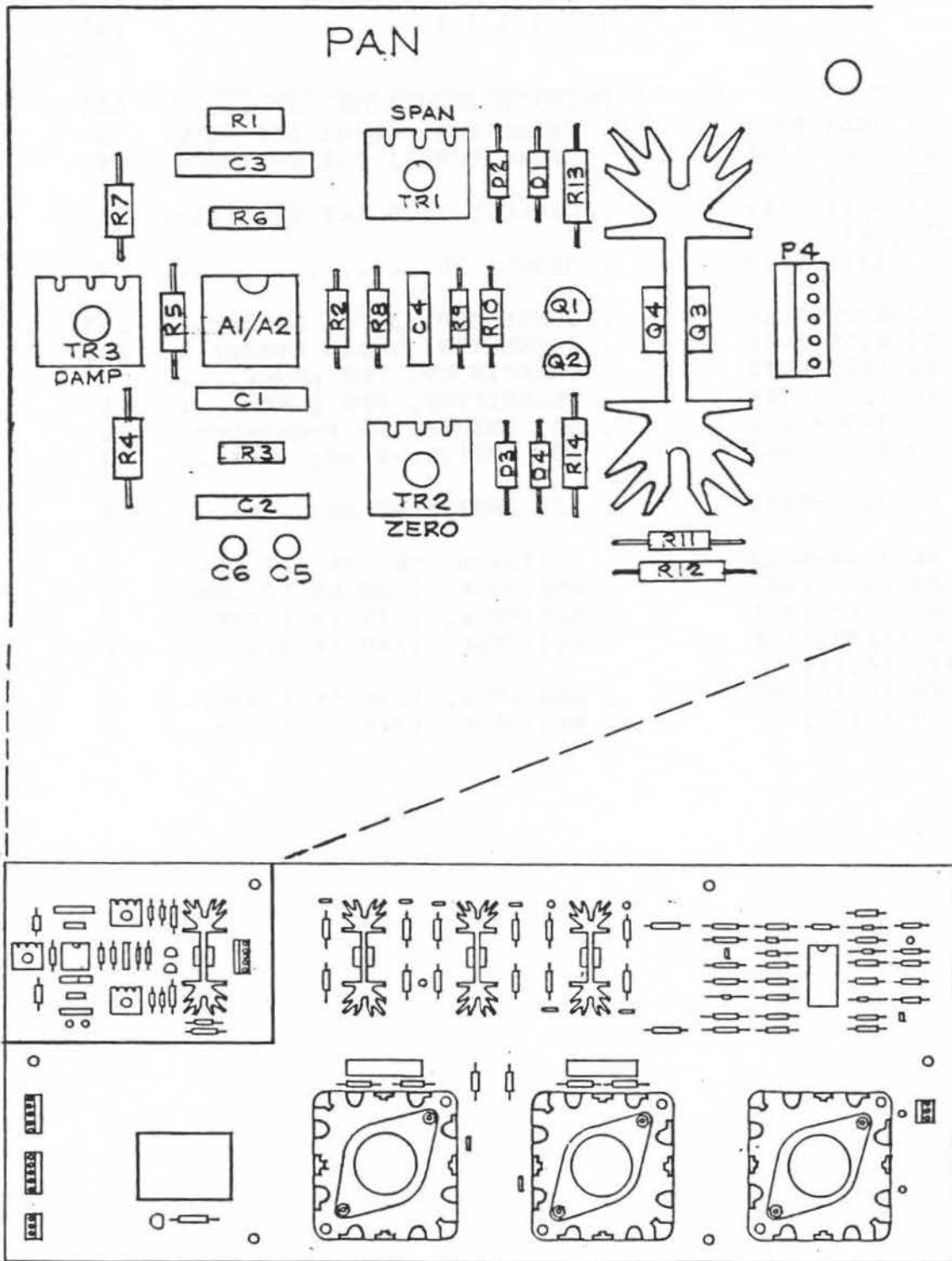

VARI*LITE
02-3002-0002

4-12. CIRCUIT CARD ASSEMBLY, SERVO POWER SUPPLY (CONT'D)

Voltage Regulator Circuit

REF DES	PART NUMBER	DESCRIPTION						QUAN PER ASSY	USABLE ON CODE
		1	2	3	4	5	6		
		VOLTAGE REGULATOR CKT.....						REF	
C1,C2	62-2005-0001	.						2	
C3,C4	62-2042-0105	.						6	
C7,C10,C11,C13									
C5,C6	62-2013-0104	.						6	
C8,C9,C12,C14									
D1,D2	82-4314-5403	.						4	
D3,D4									
P1,P5	52-6229-0001	.						ref	
P2,P3	52-6259-0001	.						ref	
Q1	80-1613-6227	.						1	
Q2	80-1612-5759	.						1	
Q3	83-3130-0001	.						1	
Q4A-	83-3103-0001	.						3	
Q6A									
Q4B-	83-3104-0001	.						3	
Q6B									
R1,R3	60-7440-0022	.						2	
R2,R4	60-2423-1007	.						2	
R5,R7	60-1225-1021	.						2	
R6,R8	60-1225-1186	.						6	
R10,R12,R14,R16									
R9,R11	60-1221-1301	.						2	
R13,	60-1223-1787	.						2	
R15									

4-12. CIRCUIT CARD ASSEMBLY, SERVO POWER SUPPLY (CONT'D)

Voltage Regulator Circuit (cont'd)

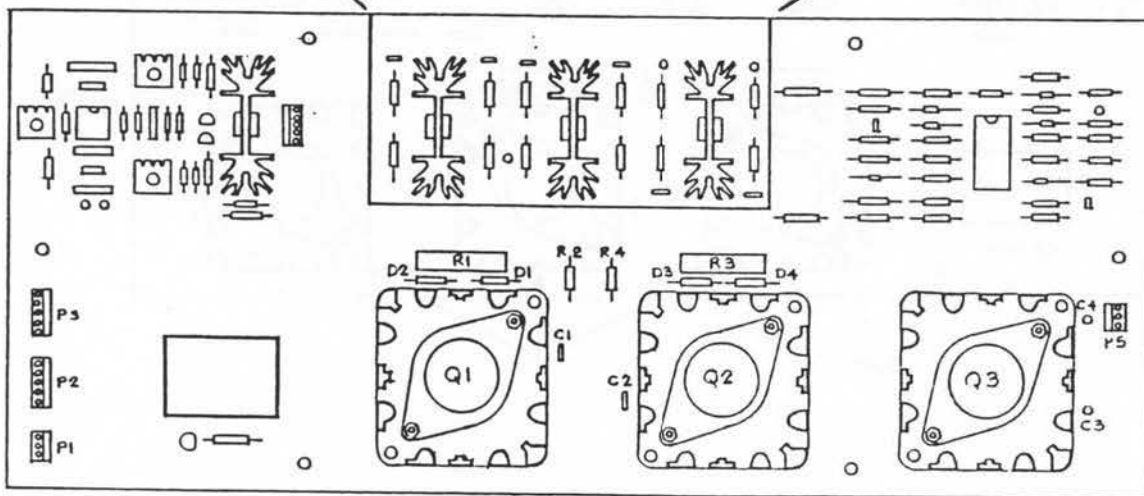
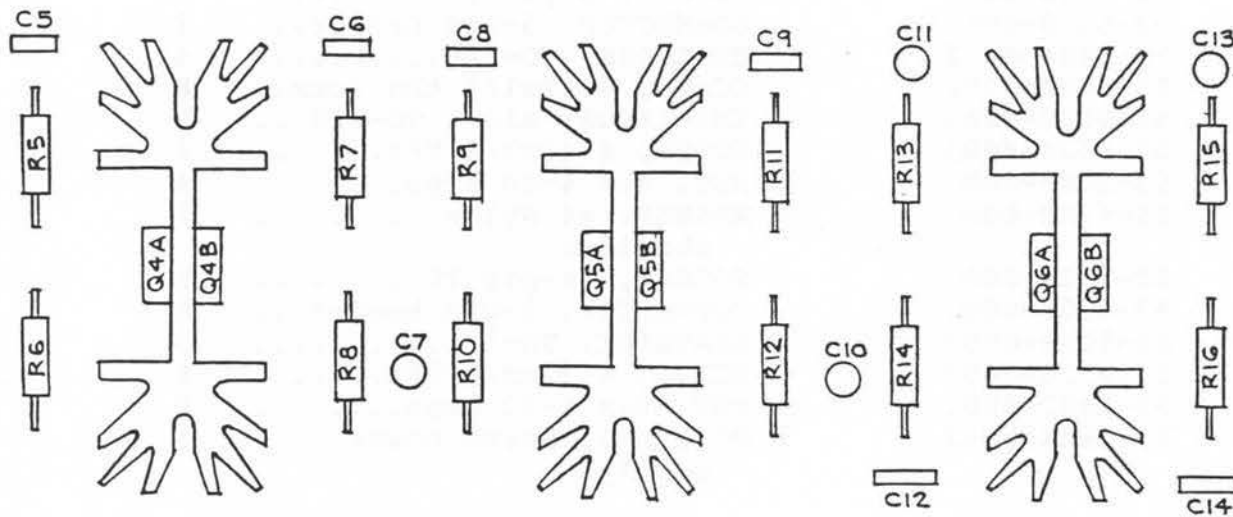

VARI*LITE
02-3002-0002

4-12. CIRCUIT CARD ASSEMBLY, SERVO POWER SUPPLY (CONT'D)

INDEX NO.	PART NUMBER	DESCRIPTION	QUAN		USABLE ON CODE
			PER ASSY	ON	
	24-9606-0063	CIRCUIT CARD ASSY, Servo.... power supply	REF		
1	50-2708-0001	. SOCKET, 8-pin IC.....	1		
2	52-6259-0001	. CONNECTOR, 5-pin header...	3		
3	51-5004-0002	. HEATSINK, TO-220.....	4		
4	53-6604-0002	. SCREW, 4-40x1/4 thd form..	8		
5	51-5006-0001	. INSULATOR, Mica, TO-220...	8		
6	53-6520-0001	. SCREW, 4-40x3/8 PPZ.....	4		
7	53-2003-0001	. NUT, Hex 4-40 keps.....	4		
8	55-6509-0001	. WASHER, #4 Nylon..... shoulder	8		
9	50-2714-0001	. SOCKET, 14-pin IC.....	1		
10	52-6229-0001	. CONNECTOR, 3-pin header...	2		
11	51-5009-0001	. HEATSINK, TO-3.....	3		
12	53-6526-0001	. SCREW, 6-32x5/8 PPZ.....	6		
13	53-2002-0001	. NUT, Hex 6-32 keps.....	6		
14	11-9606-0063	. PC BOARD, Servo power.... supply	1		

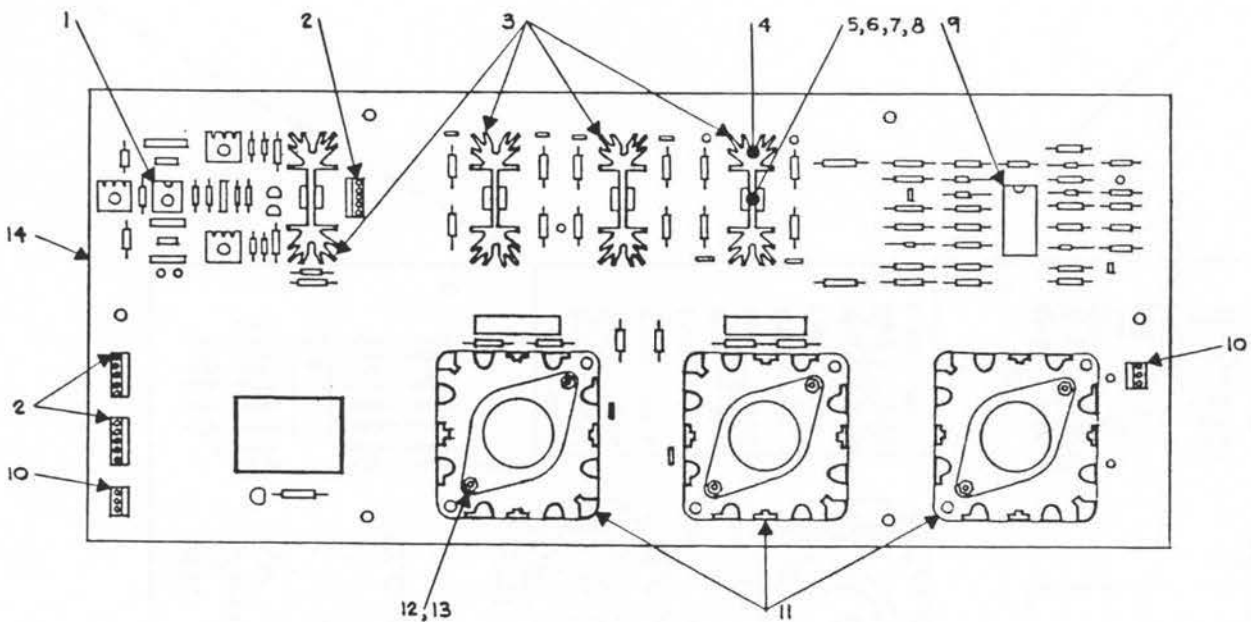

VARI*LITE
02-3002-0002

4-13. CIRCUIT CARD ASSEMBLY, DATA RECEIVER

INDEX NO.	PART NUMBER	DESCRIPTION						QUAN PER ASSY	USABLE ON CODE
		1	2	3	4	5	6		
1	50-2714-0001	.						11	
2	50-2716-0002	.						34	
3	50-2708-0001	.						5	
4	52-6240-0001	.						1	
5	52-6229-0001	.						2	
6	52-6259-0001	.						3	
7	50-2720-0001	.						1	
8	11-9606-0011	.						1	

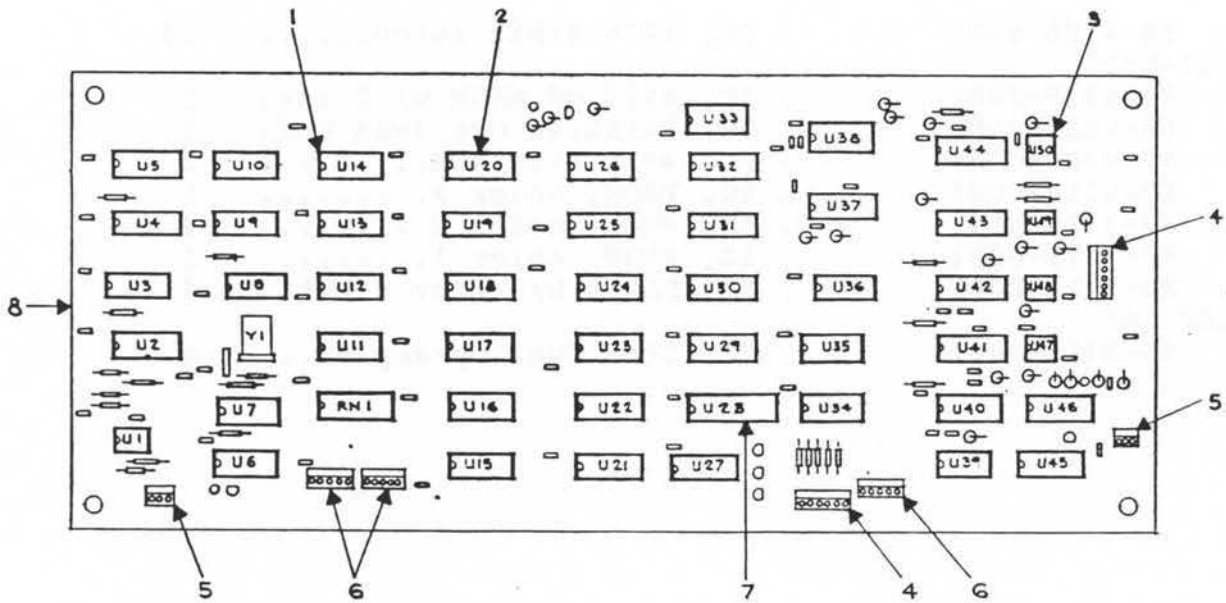

VARI*LITE
02-3002-0002

4-13. CIRCUIT CARD ASSEMBLY, DATA RECEIVER (CONT'D)

REF DES	PART NUMBER	DESCRIPTION						QUAN PER ASSY	USABLE ON CODE
		1	2	3	4	5	6		
U1	86-6102-0001	.						1	
U2, U46	84-4192-0001	.						2	
U3	84-4198-0001	.						1	
U4,U5 U8,U20	84-4203-0001	.						4	
U6	84-4110-0001	.						1	
U7	84-4176-0001	.						1	
U9, U11-U13	84-4108-0001	.						4	
U10	84-4215-0001	.						1	
U14, U19	84-4211-0001	.						2	
U15, U16	84-4207-0001	.						2	
U17, U39	84-4212-0001	.						2	
U18, U45	84-4218-0001	.						2	
U21- U26,U29-U32	84-4186-0001	.						10	
U27	84-4219-0001	.						1	
U28	84-4122-0001	.						1	
U33	84-4205-0001	.						1	
U34	87-7118-0001	.						1	
U35	87-7118-0001	.						1	
U36	87-7118-0001	.						1	
U37, U38,U40-U44	85-5114-0001	.						7	
U47- U50	83-3111-0001	.						4	

VARI*LITE
02-3002-0002

4-13. CIRCUIT CARD ASSEMBLY, DATA RECEIVER (CONT'D)

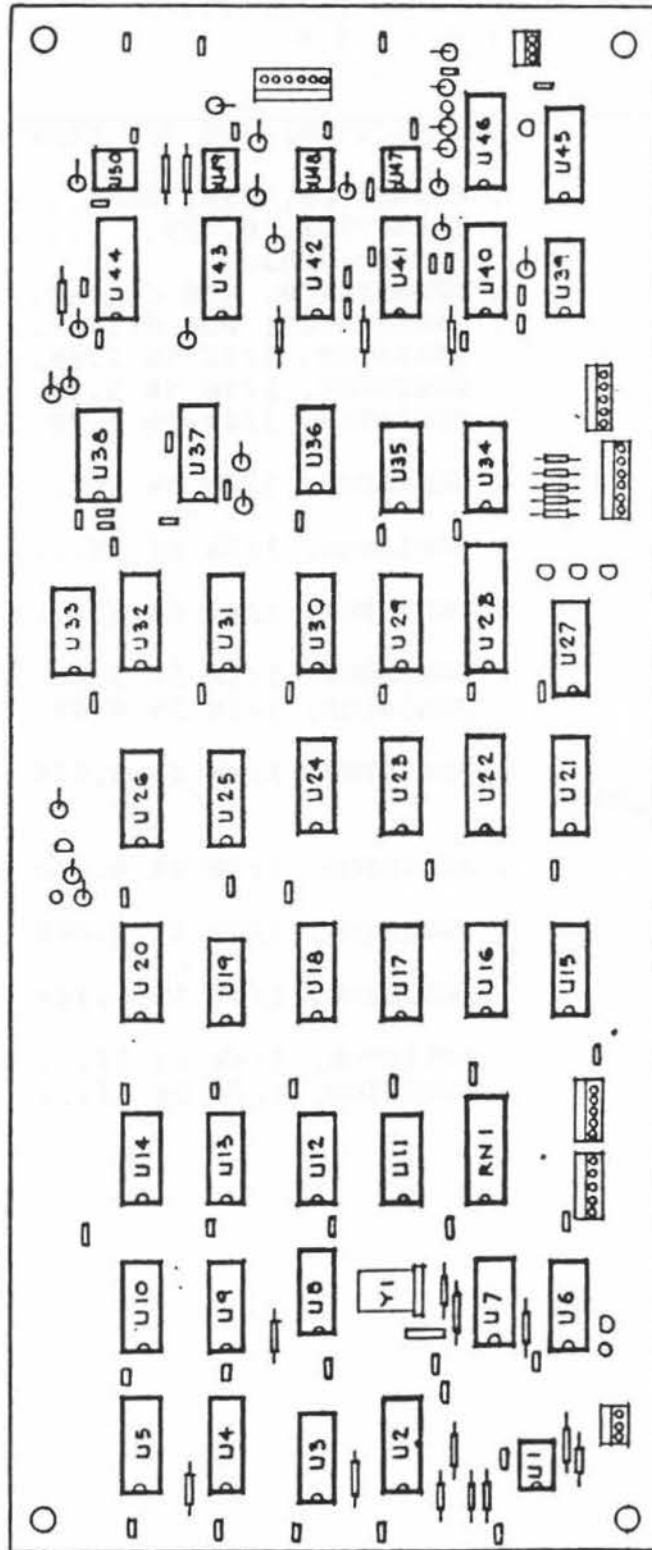

VARI*LITE
02-3002-0002

4-13. CIRCUIT CARD ASSEMBLY, DATA RECEIVER (CONT'D)

REF DES	PART NUMBER	DESCRIPTION						QUAN PER ASSY	USABLE ON CODE
		1	2	3	4	5	6		
C1,C3 C6	62-2042-0105	.						3	
C2	62-2064-0510	.						1	
C4,C5 C7-C35	62-2013-0104	.						31	
Q1-Q5 Q6	80-2513-0005 80-2513-0055	.						5 1	
R1,R2	60-1420-1503	.						2	
R3-R6 R7- R10	60-1420-2204 60-1421-4701	.						4 4	
R11- R18,R49	60-1424-1005	.						9	
R19, R23	60-1423-1004	.						1	
R20, R22,R24	60-1425-2703	.						3	
R21 R25, R51	60-1420-2206 60-1426-4703	.						1 2	
R26- R30,R33,R34,R37,R38,R40, R41,R43,R44,R46,R47	60-1231-6043	.						15	
R31, R32	60-1231-4023	.						2	
R35, R36	60-1231-3013	.						2	
R39, R42,R45,R48	60-1231-6983	.						4	
R50 R52- R56	60-1421-0001 60-1423-4702	.						1 5	

VARI*LITE
02-3002-0002

4-13. CIRCUIT CARD ASSEMBLY, DATA RECEIVER (CONT'D)

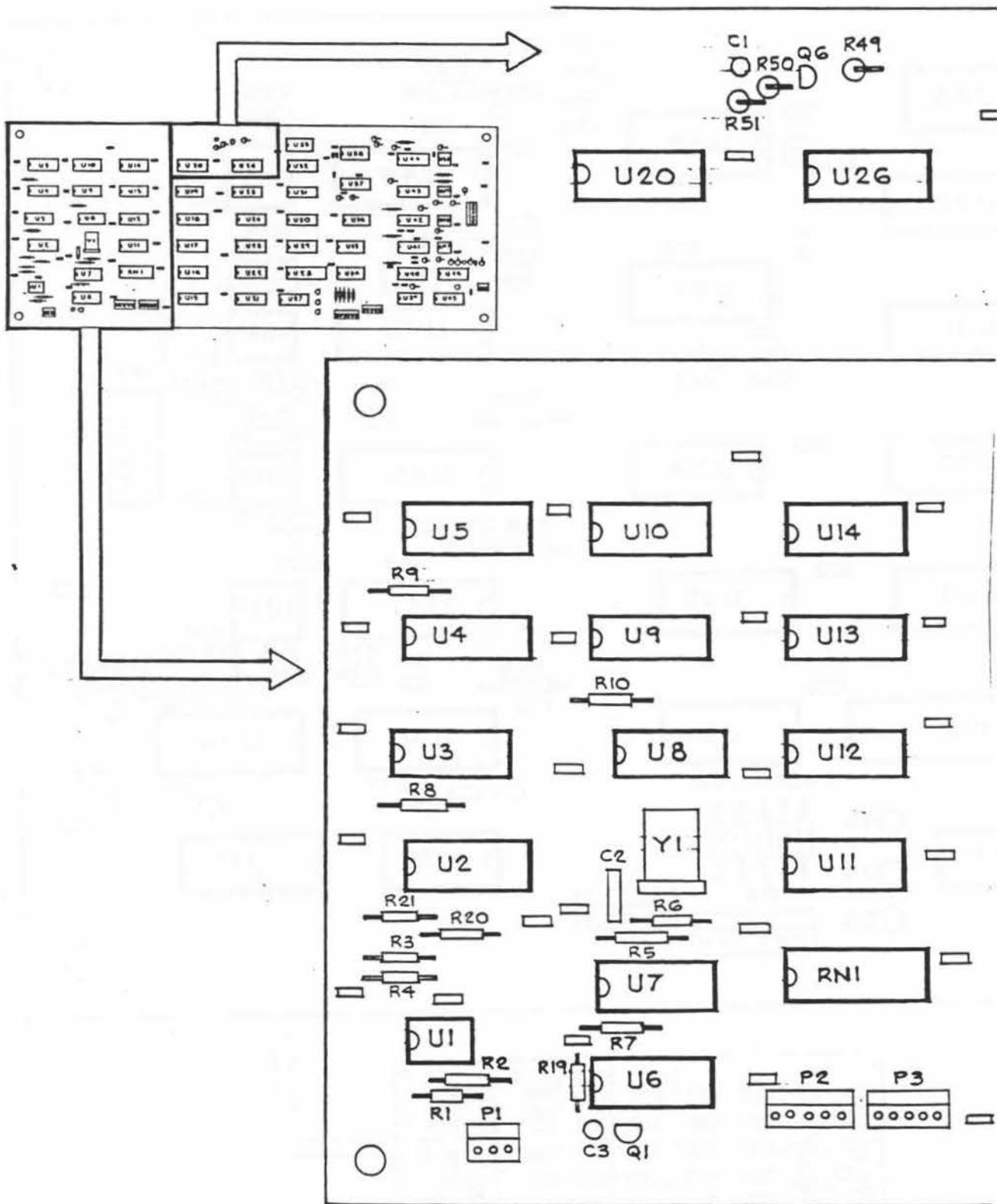

VARI*LITE
02-3002-0002

4-13. CIRCUIT CARD ASSEMBLY, DATA RECEIVER (CONT'D)

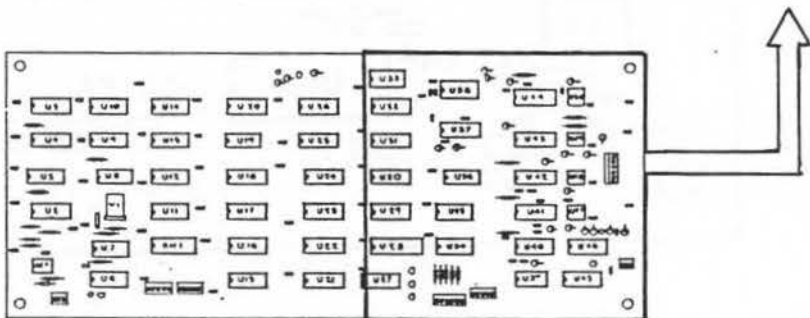
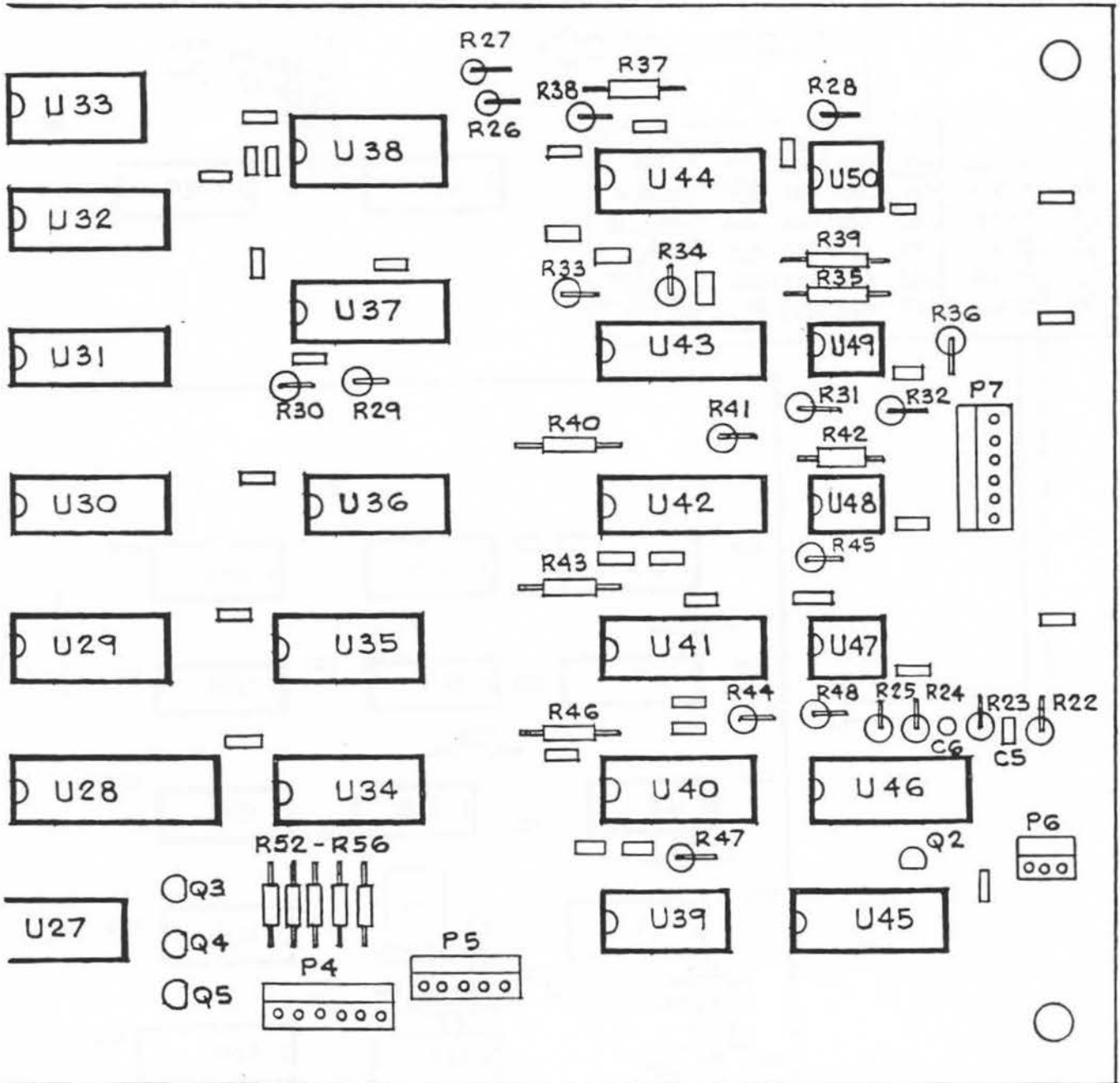

APPENDIX A

REFERENCES

1. VARI*LITE Console Operation Manual (V-L P/N 02-3001-0001).
2. VARI*LITE Console Troubleshooting Manual (V-L P/N 02-3003-0003).
3. Instruction Manual, Transistor Tester, B&K Precision Model 510.

VARI*LITE
02-3002-0002

(THIS PAGE BLANK)

APPENDIX B
BASIC ITEMS ISSUE LIST

B-1. TEST RACK EQUIPMENT SUPPLIED

Each VARI*LITE 100 Series system is supplied with at least one test rack containing tools, test equipment, and spare parts used to maintain the instruments on the road. A test rack normally contains the following items:

- o Oscilloscope, dual-trace, Tektronix 2213
- o Multimeter, digital, Fluke 8021B or Fluke 77
- o Transistor tester with probe, B&K 510
- o Dummy load with ammeter
- o Mini-controller, VARI*LITE
- o Cheater cord for test controller
- o Kit of spare parts (refer to paragraph B-3 for complete list)
- o System notebook
- o Work light
- o Tool kit (refer to paragraph B-2 for complete list)
- o Lamp, GE MARC 350/16T, several as required

VARI*LITE
02-3002-0002

B-2. TOOL KIT

The following items are normally supplied in the Vari-Lite tool kit for technicians:

<u>DESCRIPTION</u>	<u>MANUFACTURER</u>	<u>PART NUMBER</u>
Penlite	Desco or Totalite	225
Chain nose pliers, 4"	Diamond	LN-54
Plier, cutter, wrench set	Diamond	P-2
Diagonal cutter, 4"	Diamond	S-54RGP
Hex key set, large	Eklind	51
Hex key set, small	Eklind	81
Wirestripper, T-type	Ideal	T-6
Crimp tool, combination	Klein	1002
Tape measure	Lufkin	HW50
Soldering iron element	Ungar	1237-S
Soldering iron handle	Ungar	7770
Soldering iron stand	Ungar	8800
Soldering iron tip	Ungar	PL-151
Safety knife	Xacto	3021
Knife blades	Xacto	21
Screwdriver set	Xcelite	CK-3
Nutdriver set	Xcelite	HS-6-18
Allen hex set	Xcelite	PS-89
Screw/nutdriver set	Xcelite	PS-130
Slot screwdriver	Xcelite	R-3323
Phillips screwdriver, #2 pt.	Xcelite	XST-102
Phillips screwdriver, #2 long	Xcelite	XST-1020
Hook and pick	Swinger	SW-10
5/16" - 1/4" open end wrench		
1/2" - 7/16" open end wrench		
Pin extractor	AMP	305183
75' - 100' rope w/chain and pulley and clip	Elliott's	
Tool box	Union	U-7119

VARI*LITE
02-3002-0002

B-3. KIT OF SPARE PARTS

The following spare parts and assemblies are normally supplied with each test rack:

<u>SPARE ASSEMBLIES</u>	<u>PART NUMBER</u>	<u>U.S.</u>	<u>OVERSEAS</u>
Data receiver board	SD-9606-011	1	1
Iris connecting link	185	2	2
(set screw collar)	137	2	2
Iris P.O.D.	MA-9606-039	2	2
Lamp control card, EM11 & EM12	SD-9606-059	1 ea.	1 ea.
Lamp power supply		1	2
Motor w/gear, short and long pinion	7312	1 ea.	1 ea.
Thumbwheel switch and wires	23078-2	1	1
<u>SEMICONDUCTORS</u>	<u>DESCRIPTION</u>	<u>U.S.</u>	<u>OVERSEAS</u>
DAC-08CP	D-to-A Converter	5	4
HCPL-2630	Opto-coupler	2	4
ILCT6	Opto-coupler	4	4
LM2091	Comparator		2
LM318	Op Amp	2	2
LM324	Op Amp	5	10
LM339AN	Comparator	4	2
MC14076BCP	Latch	2	2
MC1458	Op Amp	10	10
MCT2	Opto-coupler	2	4
MCT6	Opto-coupler		4
MOC3041	Opto-coupler	2	2
SN74121N	One-shot	2	2
TL072CP	Op Amp	10	10
UC3524	Current Regulator	2	4
2N5679	Transistor (Rptr)	4	4
2N5681	Transistor (Rptr)	4	4
2N6122	Transistor (Servo)	5	10
2N6125	Transistor (Servo)	5	10
2N6250	Transistor (Pwr)	4	8
MPSA05	Transistor (Drvr)	5	5
MPSA55	Transistor (Drvr)	5	5
MPS3646	Transistor (Rptr)	2	2
LM317T	Voltage Regulator	1	1
LM337T	Voltage Regulator	1	1
1N4002	Diode, 1 A	2	2
100JB2L	Bridge Rect. (PS)	2	4
MDA980-2	Bridge Rect. (UPE)	2	4
2S18	Solid State Relay	2	4
2N4037	Transistor (Drvr)	2	4
2N3053	Transistor (Drvr)	2	4
C106D1	SCR	2	4
2N6227	Transistor (Pwr)	1	2
2N5759	Transistor (Pwr)	1	2

VARI*LITE
02-3002-0002

B-3. KIT OF SPARE PARTS (CONT'D)

<u>SEMICONDUCTORS</u>		<u>DESCRIPTION</u>	<u>U.S.</u>	<u>OVERSEAS</u>
LM309K		Regulator (+5V)	1	2
LM309H		Regulator (+5V)	1	2
<u>RESISTORS</u>			<u>U.S.</u>	<u>OVERSEAS</u>
121 ohm 1%			2	2
1.33k ohm 1%			2	2
3.01k ohm 1%			2	2
4.02k ohm 1%			2	2
6.01k ohm 1%			2	2
6.98k ohm 1%			2	2
1.2 ohm 1/2 watt comp.			5	5
10 ohm			2	2
39 ohm			2	2
47 ohm			2	2
220 ohm			2	2
270 ohm			2	2
470 ohm			2	2
1k ohm			5	5
1.5k ohm			2	2
2.2k ohm			2	2
4.7k ohm			2	2
10k ohm			5	5
12k ohm			5	5
15k ohm			2	2
18k ohm			5	5
22k ohm			5	5
33k ohm			2	2
47k ohm			2	2
100k ohm			2	2
470k ohm			8	8
680k ohm			2	2
1Meg ohm			2	2
<u>CAPACITORS</u>		<u>PART NUMBER</u>	<u>U.S.</u>	<u>OVERSEAS</u>
0.047uf film		C280AE/A47K	2	2
0.15uf film		C280AH/A150K	2	2
0.01uf ceramic		C280AE/A10K	2	2
0.1uf monolythic		C280AH/A100K	2	2
1.0uf tantalum		ECS-F35E1	5	10
1.0uf, 10% 630V		M5-MKT1813	1	2
12000uf 30V		8426C	1	2
<u>MISCELLANEOUS SPARES</u>		<u>PART NUMBER</u>	<u>U.S.</u>	<u>OVERSEAS</u>
Breaker, ACS 20 A		Q0-120	1	1
Connector set, AMP 3-pin		Male: 207360-1	1	1
		Female: 207359-1		
Connector, input		206708-1	1	1

VARI*LITE
02-3002-0002

B-3. KIT OF SPARE PARTS (CONT'D)

MISCELLANEOUS SPARES	PART NUMBER	U.S.	OVERSEAS
Connector, lock ring #13 (small)	206707-1	10	10
Connector, lock ring #23 (large)	206251-1	5	5
Connector set, lamp	Male: 206708-1 Female: 206705-2	1	1
Connector set, trunk	Male: 206837-1 Female: 206838-2	1	1
Connector, 24-pin, chassis-mount		1	1
Fuse, 1/4 A	MDL-1/4	2	2
Fuse, 1 A slow-blow	MDL1	5	10
Fuse, 5 A	AGC5	10	20
Fuse, 10 A	AGC10	5	10
Fuse, thermal, microtemp	4208A	2	4
Fuseholder	342028	2	2
Gear, feedback pot	GP29-96	1	1
FFA shaft	SS127	1	2
Front window, coated		1	2
Hardware assortment			
Heat shrink			
Iris leaves		20	20
Lamp retainer springs	LE-026C-5MW	2	2
Lamp socket w/ clip (clip)	MARC 350/LC-1C MD-9606-0622	2	4
Lamp yoke wires, set	8899 (black) 8899 (red)	1	1
Motor brush set	80-42-1 80-42-2	2	4
Pan/tilt pulley	48XL037	2	2
Pan/tilt pulley belt	120XL037	1	1
Pot, servo mount (10k)	7561-1001	2	3
Pot, bushing mount (10k)	7561-0002	2	2
Shroud cap	MD-9606-018	1	1
Socket, IC, 8-pin	640463-3	5	5
Socket, IC, 14-pin	640357-3	2	2
Socket, IC, 16-pin	640358-3	2	2
Spark gap, GE	GC2-350L	1	1
Spark gap, EMI	GC2-450L	1	1
Terminal, crimp, butt splice	55045-1	20	20
Terminal, pin, AMP	66098-7 (tin) 66332-8 (gold)	10	10
Terminal, socket, AMP	66100-7 (tin) 66331-8 (gold)	10	10
Terminal, crimp, lug	640933-1	20	20
Terminal, crimp, spade lug	55019-2	20	20
Trimpot 10k	3386P-1-103	2	2
Trimpot 200k	3386P-1-102	2	2

VARI*LITE
02-3002-0002

B-3. KIT OF SPARE PARTS (CONT'D)

<u>MISCELLANEOUS SPARES</u>	<u>PART NUMBER</u>	<u>U.S.</u>	<u>OVERSEAS</u>
Trimpot 500k	3386P-1-504	2	2
Transformer, universal power		1	2
Tie-wraps	T18R	50	50
Tie-wrap saddles	TM1S6	10	10
Battery, AA	MN-1500	4	4
Battery, 9V	MN-1604	1	1
Epoxy, 5 min.		1	1
Loctite 242		1	1
Lubricant		1	1
RTV tube		1	1
Solder wick		1	1
Tape, gaffers		3	5
Tape, masking		5	5
Tape, PVC		1 ea.	1 ea.
Thermal compound	2-9	1	1
Work lamp		1	1

APPENDIX C

COLOR MASTER DISK

The color master diskette is supplied with each computer. This diskette may be used at the beginning of a tour in the selection of preset colors. Each color shown on the chart has been stored into all channels in cues 1 thru 95. The cue number may be found in the upper left-hand corner of the chart. To find a desired color, recall the corresponding cue and store to color into the desired preset. The color master diskette remains exactly the same as previous initialization diskettes in all other respects (cleared display, cursor presets, channel group selects, and chase selects).

Single-filter alignments are stored in cues 100 thru 123. Step through these cues view each filter on wheel one, then wheel two, then wheel three.

Following the color chart is a list of cue numbers, color names, and filter alignments used to achieve the color. The three-digit filter alignment code represents wheels 1,2,3 respectively. Note that colors derived from combinations of three filters are less brilliant than single or double filter alignments.

COLOR

	RED	ORG	AMB	YEL	Y/G	Y+G	G/Y	GRN	G/B	B/G	BLU	B/V	VIO	MAG
	C0	C1	C2	C3	C4	C5	C6	C7	C8	C9	C10	C11	C12	C13
S0	1 WHITE													
S1	2 ORANGE	7 PEACH ORANGE	15 BASTARD AMBER *	24 PALE YELLOW GREEN *	31 FROST PALE BLUE	37 LIGHT LIME	42 PALE PALE GREEN	49 STEEL TURQUOISE	56 TURQUOISE	61 HOCO BLUE *	69 PALE BLUE *	75 DARK STEEL BLUE	80 CYAN *	87 MULTI PEACH
S2			16 LIGHT BASTARD AMBER	25 LIGHT YELLOW GREEN *	32 YELLOW GREEN *	38 LIME	43 FROST PALE BLUE	50 PINE GREEN	57 BLUE GRASS GREEN		70 STEEL BLUE *			88 PINK
S3		8 DEEP SALMON	17 YELLOW	26 LIGHT YELLOW GREEN II	33 BANANA GREEN	39 MED. LIME	44 PALE GREEN		58 BERMUDA GREEN	62 GRAB BAG BLUE	71 LIGHT BLUE *			
S4	3 RED *		18 LIGHT GREEN YELLOW	27 AMBER *				51 PRIMARY GREEN	59	63 MERCURY VAPOR		76 MED. BLUE *	81 MULTI LAV	89 SURFRISH LAV
S5		9 SHERBERT ORANGE		20 GREEN STRAW	34 PEA GREEN	40 DARK LIME	45 LIGHT GREEN	52 MED. YELLOW GREEN	SEA GREEN	64 VIRGIN AQUA	72 BLUE *			90 LAV.
S6		10 ORANGE AMBER	19 PEACH *	29 YELLOW GREEN I	35 DARK PEA GREEN		46 GREEN	53 SPRING GREEN		65 ARCTIC AQUA	73 MED. BLUE II		82 DEEP PURPLE	91 MAGENTA *
S7	4 MED. RED	11 DEEP ORANGE	20 LEMON AMBER				47 SPLIT PEA GREEN		60	66 AQUA		77 DARK BLUE *	83 DARK LAV *	92 ROSE
S8		12 RED ORANGE *	21 ORANGE *					54 MOON GREEN	PEAT MOSS GREEN	67 CARIB-BEAN BLUE		78 MOON LIGHT BLUE	84 NOCTURNAL BLUE	93 SURFRISH BLUE/LAV
S9	5 DARK RED *	13 LIGHT ORANGE AMBER	22 FROST AMBER	30 FROST YELLOW GREEN	36 DARK MOSS GREEN	41 DARK YELLOW GREEN	48 DARK SPLIT PEA GREEN	55 INV-SIBLE GREEN		68 BLUE GREEN	74 MID-NIGHT BLUE	79 PURPLE	85 UV *	94 SUPER BLACK
S10	6 DARK RED II	14 DEEP ORANGE AMBER	23 FROST AMBER II										86 DEEP UV	95 BLACK
S11	BLACK	→	→	→	→	→	→	→	→	→	→	→	→	→
S12	BLACK	→	→	→	→	→	→	→	→	→	→	→	→	→

* DENOTES A ONE FILTER LINE-UP
 CUE NUMBERS FOR COLOR MASTER DISKETTE ARE FOUND IN EACH COLOR BOX.

COLOR/SATURATION CHART

VARI* LITE
 02-3002-0002

SATURATION

C-2

VARI*LITE
02-3002-0002

COLOR MASTER DISKETTE

Cue/Color/Alignment Table

<u>CUE#</u>	<u>COLOR</u>	<u>ALIGNMENT</u>
1	White	000
2	Orange	570
3	Red	700
4	Medium Red	770
5	Dark Red	600
6	Dark Red II	670
7	Peach Orange	531
8	Deep Salmon	530
9	Sherbet Orange	350
10	Orange Amber	541
11	Deep Orange	540
12	Red Orange	070
13	Light Orange Amber	571
14	Deep Orange Amber	701
15	Bastard Amber	400
16	Light Bastard Amber	401
17	Yellow	410
18	Light Green Yellow	051
19	Peach	050
20	Lemon Amber	061
21	Orange	060
22	Frost Amber	561
23	Frost Amber II	071
24	Pale Yellow Green	010

VARI*LITE
02-3002-0002

COLOR MASTER DISKETTE (Cont'd)

Cue/Color/Alignment Table (cont'd)

<u>CUE#</u>	<u>COLOR</u>	<u>ALIGNMENT</u>
25	Light Yellow Green	020
26	Light Yellow Green II	041
27	Amber	040
28	Green Straw	411
29	Yellow Green	052
30	Frost Yellow Green	063
31	Frost Pale Blue	402
32	Yellow Green	030
33	Banana Green	031
34	Pea Green	042
35	Dark Pea Green	412
36	Dark Moss Green	053
37	Light Lime	021
38	Lime	032
39	Medium Lime	043
40	Dark Lime	413
41	Dark Yellow Green	054
42	Pale Ale Green	011
43	Frost Pale Blue II	403
44	Pale Green	022
45	Light Green	033
46	Green	044
47	Split Pea Green	414
48	Dark Split Pea Green	444

VARI*LITE
02-3002-0002

COLOR MASTER DISKETTE (Cont'd)

Cue/Color/Alignment Table (cont'd)

<u>CUE#</u>	<u>COLOR</u>	<u>ALIGNMENT</u>
49	Steel Turquoise	012
50	Pine Green	023
51	Primary Green	034
52	Medium Yellow Green	330
53	Spring Green	331
54	Moon Green	341
55	Invisible Green	045
56	Turquoise	013
57	Bluegrass Green	320
58	Bermuda Green	024
59	Sea Green	321
60	Peat Moss Green	035
61	No Color Blue	001
62	Grab Bag Blue	522
63	Mercury Vapor	404
64	Virgin Aqua	310
65	Arctic Aqua	014
66	Aqua	025
67	Caribbean Blue	026
68	Blue Green	036
69	Pale Blue	002
70	Steel Blue	003
71	Light Blue	004

VARI*LITE
02-3002-0002

COLOR MASTER DISKETTE (Cont'd)

Cue/Color/Alignment Table (cont'd)

<u>CUE#</u>	<u>COLOR</u>	<u>ALIGNMENT</u>
72	Blue	005
73	Medium Blue II	016
74	Midnight Blue	027
75	Dark Steel Blue	301
76	Medium Blue	006
77	Dark Blue	007
78	Moonlight Blue	017
79	Purple	210
80	Cyan	300
81	Multi-Lavender	512
82	Deep Purple	405
83	Dark Lavender	200
84	Nocturnal Blue	207
85	UV	100
86	Deep UV	107
87	Multi-Peach	521
88	Pink	520
89	Surprise Lavender	511
90	Lavender	501
91	Magenta	500
92	Rose	510
93	Surprise Blue/Lavender	502
94	Super Black	666
95	Black	777

VARI*LITE
02-3002-0002

COLOR MASTER DISKETTE (Cont'd)

Single Filter Alignment Table

<u>CUE#</u>	<u>COLOR</u>	<u>ALIGNMENT</u>
100	White	000
101	UV	100
102	Dark Lavender	200
103	Cyan	300
104	Bastard Amber	400
105	Magenta	500
106	Dark Red	600
107	Red	700
108	White	000
109	Pale Yellow Green	010
110	Light Yellow Green	020
111	Yellow Green	030
112	Amber	040
113	Peach	050
114	Orange	060
115	Red Orange	070
116	White	000
117	No Color Blue	001
118	Pale Blue	002
119	Steel Blue	003
120	Light Blue	004
121	Blue	005
122	Medium Blue	006
123	Dark Blue	007

VARI*LITE
02-3002-0002

(THIS PAGE BLANK)

APPENDIX D

MAINTENANCE COLLECTION CODES

The maintenance collection system does not require lengthy written symptom and repair descriptions, which take too much time to prepare and are difficult to interpret. Calibrations and adjustments need not be reported. Only hard failures of parts should be reported.

To report a fix, write the three-letter code for the luminaire section in the SYMPTOM column, and the three-letter code for the repair in the FIX column. Report the serial number, hour meter reading, the date, and your name for each fix. City and venue need not be reported.

The following symptom and repair codes shall be used until further notice. If no code is provided for a given maintenance action, that action need not be reported.

VARI*LITE
02-3002-0002

SERIES 100 MAINTENANCE COLLECTION CODES

UPE - UPPER ENCLOSURE

BDG - Replaced Bridge Rectifier
THM - Replaced Thumbwheel
XFM - Replaced Transformer
12K - Replaced 12,000 uf Filter Capacitor
15K - Replaced 15,000 uf Filter Capacitor

YOK - YOKE

LAM - Replaced Lamp Cable(s)
MUL - Replaced Multicore Cable
YOK - Replaced Yoke

IRI - IRIS

BSH - Replaced Motor Brushes
FBP - Replaced Feedback Pot
ILV - Replaced Iris Leaves
MTR - Replaced Motor
POD - Replaced Pupil Obstruction Device

PTB - PAN/TILT BRACKET

BLT - Replaced Belt
BSH - Replaced Motor Brushes
MTR - Replaced Motor
PPL - Replaced Pan Pulley
SMP - Replaced Servo Mount Pot
TPL - Replaced Tilt Pulley

WSB - WHEEL SERVO BOARD

DAM - Replaced Damping Trimpot
SPA - Replaced Span Trimpot
ZER - Replaced Zero Trimpot
A05 - Replaced MPSA05 Transistor
A55 - Replaced MPSA55 Transistor
T72 - Replaced TL072 IC Chip
622 - Replaced 2N6122 Transistor (Tip 41)
625 - Replaced 2N6125 Transistor (Tip 42)

LPS - LAMP POWER SUPPLY CONTROL BOARD

A05 - Replaced MPS A05 Transistor
CT6 - Replaced ILCT6 IC Chip
309 - Replaced LM309 Voltage Regulator

VARI*LITE
02-3002-0002

SERIES 100 MAINTENANCE COLLECTION CODES (Cont'd)

SPS - SERVO POWER SUPPLY

1UF - Replaced 1uf Tantulum Capacitor
2N5 - Replaced 2N5759 Transistor
2N6 - Replaced 2N6227 Transistor
309 - Replaced LM309 Voltage Regulator
317 - Replaced LM317 Voltage Regulator
337 - Replaced LM337 Voltage Regulator

RCV - RECEIVER BOARD

DAC - Replaced DAC08 IC Chip
PRM - Replaced 6301-J Color Prom IC Chip
458 - Replaced 1458 IC Chip
572 - Replaced 4572 IC Chip
630 - Replaced 2630 IC Chip

LPS - LAMP POWER SUPPLIES

BDG - Replaced Bridge Rectifier
MOC - Replaced MOC3041 IC Chip
MRO - Replaced Microtemp Fuse
PWR - Replaced Power Transistor (On Heatsink)
SCR - Replaced SCR
SPK - Replaced Spark Gap
SSR - Replaced Solid State Relay
CT2 - Replaced MCT2 IC Chip
LM3 - Replaced LM324 IC Chip
037 - Replaced 2N4037 Transistor
053 - Replaced 2N3053 Transistor
2N2 - Replaced 2N2222 Transistor
339 - Replaced LM339 IC Chip
524 - Replaced UC3524 IC Chip
559 - Replaced 2N6559 Transistor
600 - Replaced 1uf 600 Volt Capacitor
622 - Replaced 2N6122 Transistor (Tip 41)
625 - Replaced 2N6125 Transistor (Tip 42)
741 - Replaced 74121 Transistor
907 - Replaced 2N2907 Transistor

FFA - FILTER FOCAL ASSEMBLY

ASP - Replaced Aspheric Lens	GB7 - Replaced Drain Gobo
BBR - Replaced Bronze Bearing	MTR - Replaced Motor
BSH - Replaced Motor Brushes	RHG - Re-glue Hub Gear
BWA - Replaced Bronze Washer	SHF - Replaced Shaft
FBG - Replaced Feedback Pot Gear	TEF - Replaced Teflon Washer
FBP - Replaced Feedback Pot	WHL - Replaced Wheel
GB6 - Replaced Slit Gobo	WAS - Replaced Rubber Washer

VARI*LITE
02-3002-0002

SERIES 100 MAINTENANCE COLLECTION CODES (Cont'd)

FIL - FILTERS

111 - Cracked UV	311 - Cracked No Color Blue
112 - Shifted UV	312 - Shifted No Color Blue
113 - Peeled UV	313 - Peeled No Color Blue
121 - Cracked Dark Lavender	321 - Cracked Pale Blue
122 - Shifted Dark Lavender	322 - Shifted Pale Blue
123 - Peeled Dark Lavender	323 - Peeled Pale Blue
131 - Cracked Cyan	331 - Cracked Steel Blue
132 - Shifted Cyan	332 - Shifted Steel Blue
133 - Peeled Cyan	333 - Peeled Steel Blue
141 - Cracked Bastard Amber	341 - Cracked Light Blue
142 - Shifted Bastard Amber	342 - Shifted Light Blue
143 - Peeled Bastard Amber	343 - Peeled Light Blue
151 - Cracked Magenta	351 - Cracked Blue
152 - Shifted Magenta	352 - Shifted Blue
153 - Peeled Magenta	353 - Peeled Blue
161 - Cracked Dark Red	361 - Cracked Medium Blue
162 - Shifted Dark Red	362 - Shifted Medium Blue
163 - Peeled Dark Red	363 - Peeled Medium Blue
171 - Cracked Red	371 - Cracked Dark Blue
172 - Shifted Red	372 - Shifted Dark Blue
173 - Peeled Red	373 - Peeled Dark Blue
211 - Cracked Pale Yellow Green	
212 - Shifted Pale Yellow Green	
213 - Peeled Pale Yellow Green	
221 - Cracked Light Yellow Green	
222 - Shifted Light Yellow Green	
223 - Peeled Light Yellow Green	
231 - Cracked Yellow Green	
232 - Shifted Yellow Green	
233 - Peeled Yellow Green	
241 - Cracked Amber	
242 - Shifted Amber	
243 - Peeled Amber	
251 - Cracked Peach	
252 - Shifted Peach	
253 - Peeled Peach	
261 - Cracked Orange	
262 - Shifted Orange	
263 - Peeled Orange	
271 - Cracked Red Orange	
272 - Shifted Red Orange	
273 - Peeled Red Orange	