

621.32

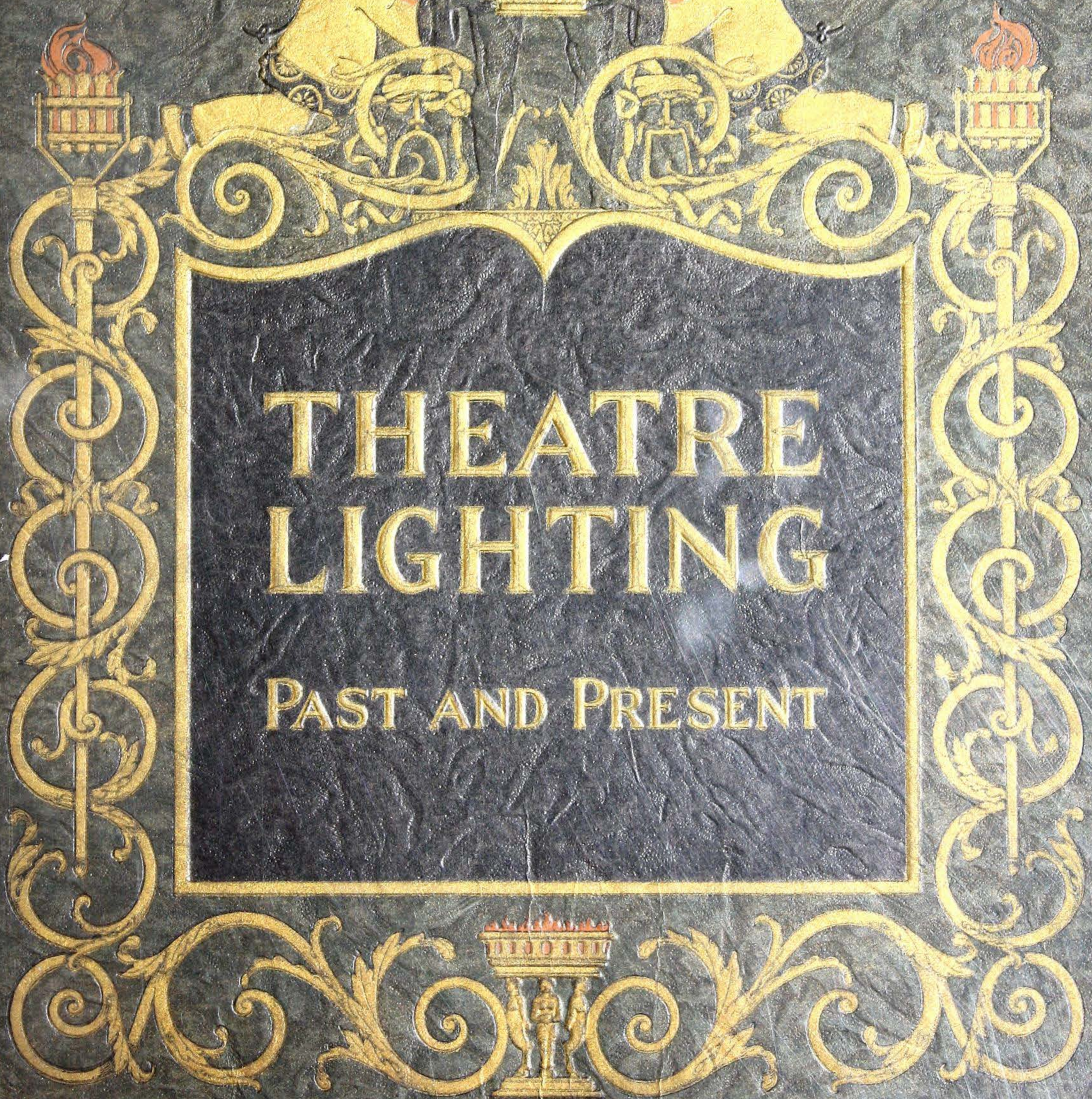

THEATRE LIGHTING

PAST AND PRESENT



THEATRE
LIGHTING
PAST AND PRESENT



[BLANK PAGE]



CCA

Copyright 1923
Ward Leonard Electric Company
Mount Vernon, N. Y.

THEATRE LIGHTING

Past and Present



(1923)

Ward Leonard Electric Company
Mount Vernon, New York

WITHOUT perfect control, lighting in the theatre, instead of being an irresistible means to every end of dramatic effect, would be continuously a hindrance and a stumbling block. Of course, the crux of control in electric lighting is in the Dimmer System—and there, perhaps, more than in any other single department, the Ward Leonard Electric Company has excelled and does excell all competitors. I am sure that without the aid I have received through their cooperation, during many years, I could not have achieved many of the finest, most beautiful effects which it has been my privilege to set before an appreciative public.

DAVID BELASCO

F O R E W O R D

THERE is no art more important in the modern theatrical production than the skilful use of light.

Scenic effects that are realistic and lifelike are made possible by perfectly controlled lighting of varying intensity and color; then, too, proper lighting has a psychological value, causing the audience to absorb the atmosphere and feeling of the play without realizing how the effect is produced.

Eminent theatrical producers have always recognized the desirability of lighting control. Indeed, most of them even to the present day have been, and still are, pioneers in the development of lighting technique. Especially is this true of electric lighting. In fact, one of the earliest practical applications of electric lighting was in the Paris Opera, where it was first used in 1846.

In looking up the history of theatre lighting we found no record of a comprehensive assembly of historical facts. Therefore, we have included a brief outline of the history of theatre lighting in this book, the prime purpose of which is to present the development, construction and use of the Ward Leonard theatre lighting control system.

We believe that many of the facts included in this book will be of interest to theatrical producers and lighting experts. If any of our readers find the subject matter worthy of comment, we shall be glad to receive criticisms and additional data which may be included in a later edition.

WARD LEONARD ELECTRIC COMPANY

171
LEONARD

Das Kupfferblatt N. 12.

Sciena di
Comœ-
dia.Das Kupf-
ferblatt
N. 12.

Es ist ein Sciena di Comœdia, als ein
Brucken darob die Gespiel agirt, oder gehalten wer-
den/ darvon in meinem offternandten Reißbuch
am. 87. Blat auch etwas gemeldet ist worden. Zu
einem solchen grossen Werck solle die Brucken vornen, 24. Braza,
hinden aber, 12. Braza breit/ vnd, 20. Braza in ihr länge haben/
die vordere Nebenwand / so zum thail der Umbhang bedeckt/
seind, 3. Braza breit / dahin gemaint / damit man vor selbigen
Wänden nit hinder die Sciena sehen möge. Hinder diese Wand
wirdt ein anzahl Lichter / oder Dellampen innwendig gesetzt /
welche ein grossen splendor oder Glantz auff die Sciena, vñ auch
in das Gewülck werffen/ derselbige aber begibt sich auß der Scie-
na widerumben also herfür/ daß man bey nächlicher Zeit nit an-
derst/ als den klaren Tag zu haben vermennt. Vornen ist die
Brucken mit einer, 3. Braza hohen Wand versehen/ welche einem
Mann fast biß an das Aug des Gesichts langen mag/ dardurch
die Prospectiva wol erhaben wirdt / vnd desto schönern Augen-
lust mitbringen thut. Gleich hinder diser ersten Wand hat es
einen Graben/ der ist, $1\frac{1}{2}$. Braza breit/ in welchem die Musici vn-
gesehen gute gelegenheit haben. An der einen seiten vnd innwen-
dig an diese Wand wirdt ein Summa Dellampen gehenckt/ se-
doch solche außserhalb nit erschen/ sonder allein ein grosser glantz/
der darvon/ als wie auch oben gemeldet worden/ in die Sciena di
Comœdia fällt/ vnd nit anderst als obs Tag were/ zu spüren ist /

Figure 1—One of the earliest references to theatre lighting in literature—
Sciena di Comoedia, 1628, by Joseph Furtenbach.

TRANSLATION

"The stage is like a bridge upon which the play is unfolded. It is described in my oft mentioned drawing book on page 87. For such a big play, the front of the stage should be 24 Braza wide, the back of the stage 12 Braza wide, 20 Braza is the length. The side screens or wings which are partly covered by the curtain are 3 Braza wide for the purpose of preventing the audience from seeing behind the scenes. Behind these wings there are a number of candles or oil lamps which light the scenes with great splendor and brilliancy. It also shines on the clouds and produces an effect that is like bright daylight in the night-time. In front of the stage there is a 3 Braza high wall which reaches almost up to a man's eye. Just behind this wall there is a space approximately $1\frac{1}{2}$ Braza wide, in which the musicians are located out of sight of the audience. On the rear of this wall there is mounted a row of oil lamps concealed from the audience but throwing a strong light on the stage, giving the effect of daylight as mentioned above."

HISTORICAL NOTES

BIRTH OF THE THEATRE

IN a circular space at the foot of a hill, hundreds of years before the Christian Era, Greek choruses danced and sang by the light of day in honor of Dionysus, the God of Wine. The spectators were accommodated on rows of seats rising one above the other up the slope. In the center of the ring there stood a sacrificial table and the leader of the chorus, following a natural impulse, would occasionally mount this table so that he might be more effective. Thus this table was the beginning of the

Greek stage which at a later date was built at the back of the circle, or orchestra, in the form of a narrow platform.

ROMAN THEATRE

The Romans followed the general theatre plan of the Greeks, but their architectural system of arches enabled them to erect the entire edifice, with its tiers of seats, from the level ground. They enlarged the stage, introduced drop curtains, provided dressing rooms for the actors, and placed seats in the orchestra for Senators and other distinguished persons.

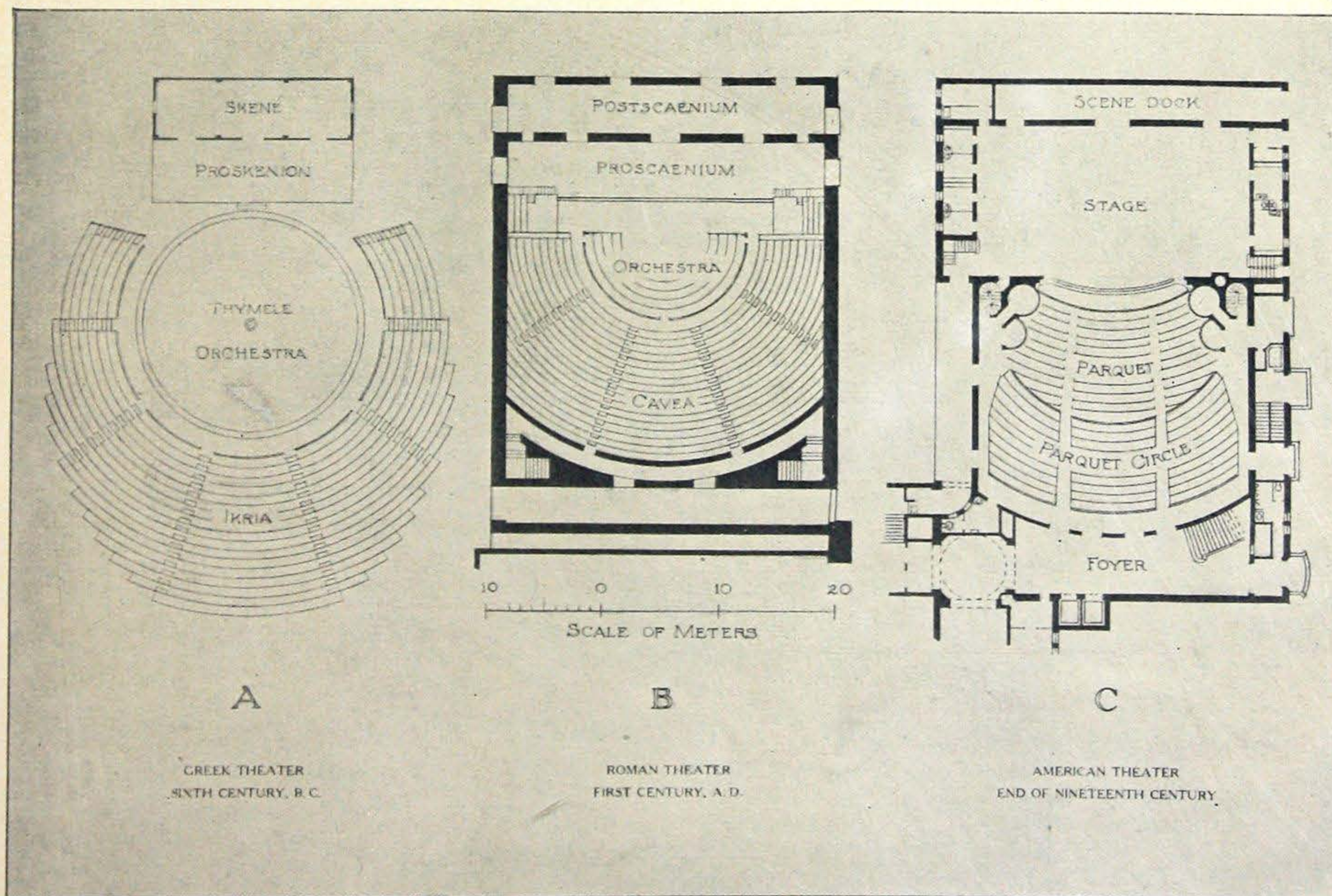

Figure 2—Development of the modern theatre from the ancient theatres of Greece and Rome.
From *The Brickbuilder*, December, 1914.

ORIGIN OF DRAMA

About the middle of the sixth century B. C., dramatic exhibitions were introduced and they soon became contests in literary and musical skill. The first tragedy competition is said to have been won by Thespis in the year 535 B. C. These spectacles were usually presented during the festivals and evidently the populace showed great interest in them for one theatre at Athens is said to have accommodated 30,000 persons.

Realistic scenic effects in the modern sense were unknown. The spectacles were presented by daylight, and the dignified architecture of the stage building itself was the scene of action.

For four hundred years after the advent of the Christian Era the ancient dramas flourished, then they seem to have gradually disappeared and finally became buried in obscurity.

MIRACLE PLAYS

In the year 1110 we find the first traces of a long series of "Miracle Plays", so termed because they exhibited events and mysteries of scripture. They originated through a desire to enlighten the people in the rudiments of Christianity. These scriptural plays were the earliest dramatic entertainments in all parts of Europe. They were first presented on rough platforms

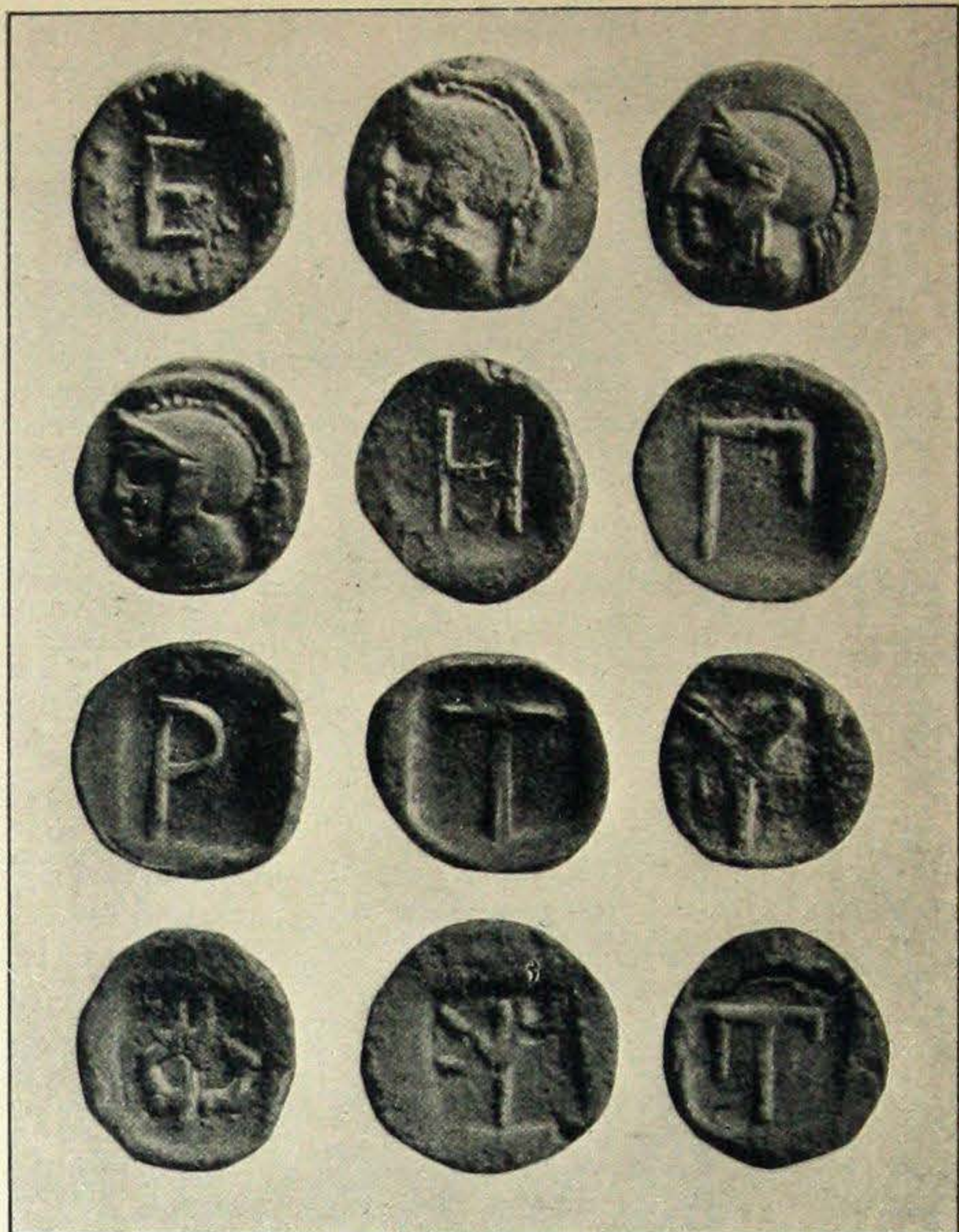
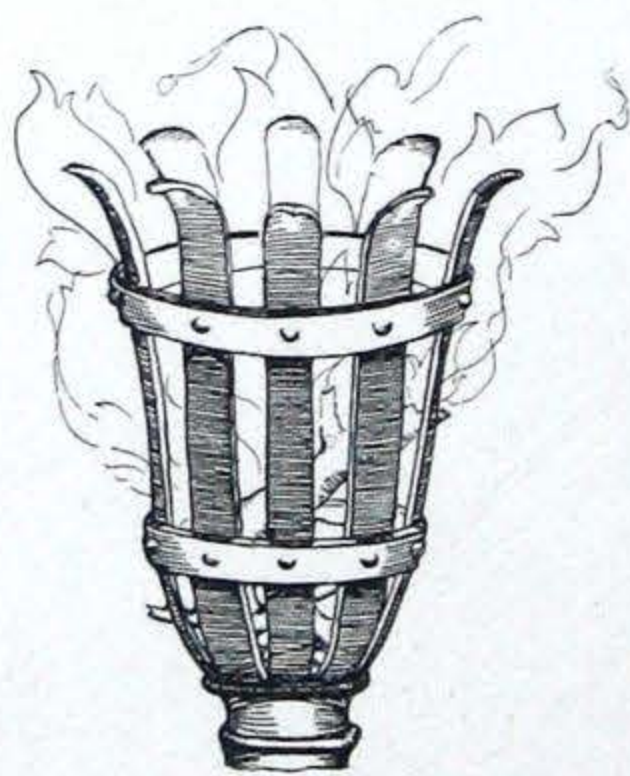

Figure 3—Admission checks to theatre at Dionysus Greece.—From *The Brickbuilder*.

erected within churches or close by. As their popularity increased, stages were built in public squares or large open fields, the audience or spectators sitting in the open. Various forms of construction were used to accommodate the different scenes, which were really a series of tableaux. In some cases three stages were arranged side by side, inclined at obtuse angles, and the spectators turned from one to another with each change of scene. Other stages were built one above the other; a structure



THE earliest form of light source was the blazing pine knot. An iron basket called a "cresset" acted as holder for the flaming wood. The design here shown was used in the fifteenth century.

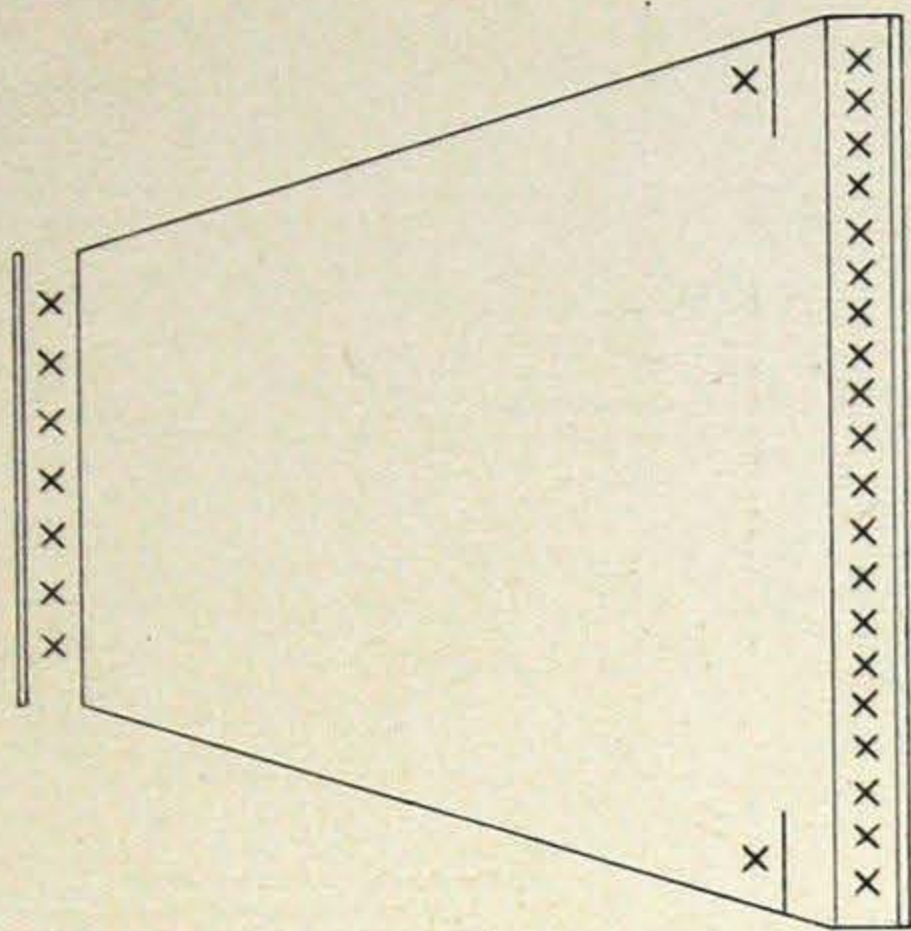

Figure 4—Diagrammatic sketch of the stage described by Joseph Furtenbach in 1628 (see figure 1).

of nine stories was erected at Metz in 1427.

Portable stages were also in general use at this time. Mounted on wheels they resembled a small two-story house with one side removed. The stage was on one level, the other being devoted to dressing rooms. These portable stages were drawn from place to place, and thus the theatre as well as the play was brought to the people in isolated sections of the country.

STAGE LIGHTING INTRODUCED

The performances of the fifteenth century were mostly given by daylight, and it seems probable that the first artificial lighting was introduced at this time in the shape of sconces of candles burned before a shrine. The literature at this time gives vague references of the use of flares and squibs to give local color to the devils,

thus marking the realization of the value of lighting for its psychological influence, entirely aside from its use for illumination.

PROGRESS OF THE DRAMA

A new species of plays called "Moralities" became popular about the middle of the fifteenth century. In these productions, vices, virtues, mental attributes and the like were personified by the various characters. Following the Morality plays, Comedies and Tragedies based on historical events, romance and many other interesting subjects made their appearance. About the year 1591 the great luminary of the dramatic world, "Shakespeare," blazed forth and produced in quick succession a series of plays, which have for two centuries and a half found few if any equals.

BEGINNING OF MODERN THEATRE

In the sixteenth century, although most theatrical performances took place on stages set in court-yards, there were a number of instances where special buildings were constructed for the presentation of plays. Usually these theatres were circular in form and open to the sky, the stage alone being sheltered from storms. Theatres of this kind were constructed in England and on the continent.

Toward the close of the sixteenth century, completely enclosed theatres were erected in England. Performances were given in the



Figure 5—Thomas Wignell, manager of the John Street theatre, lighting President Washington to his box. Taken from Hornblow's History of the Theatre in America.

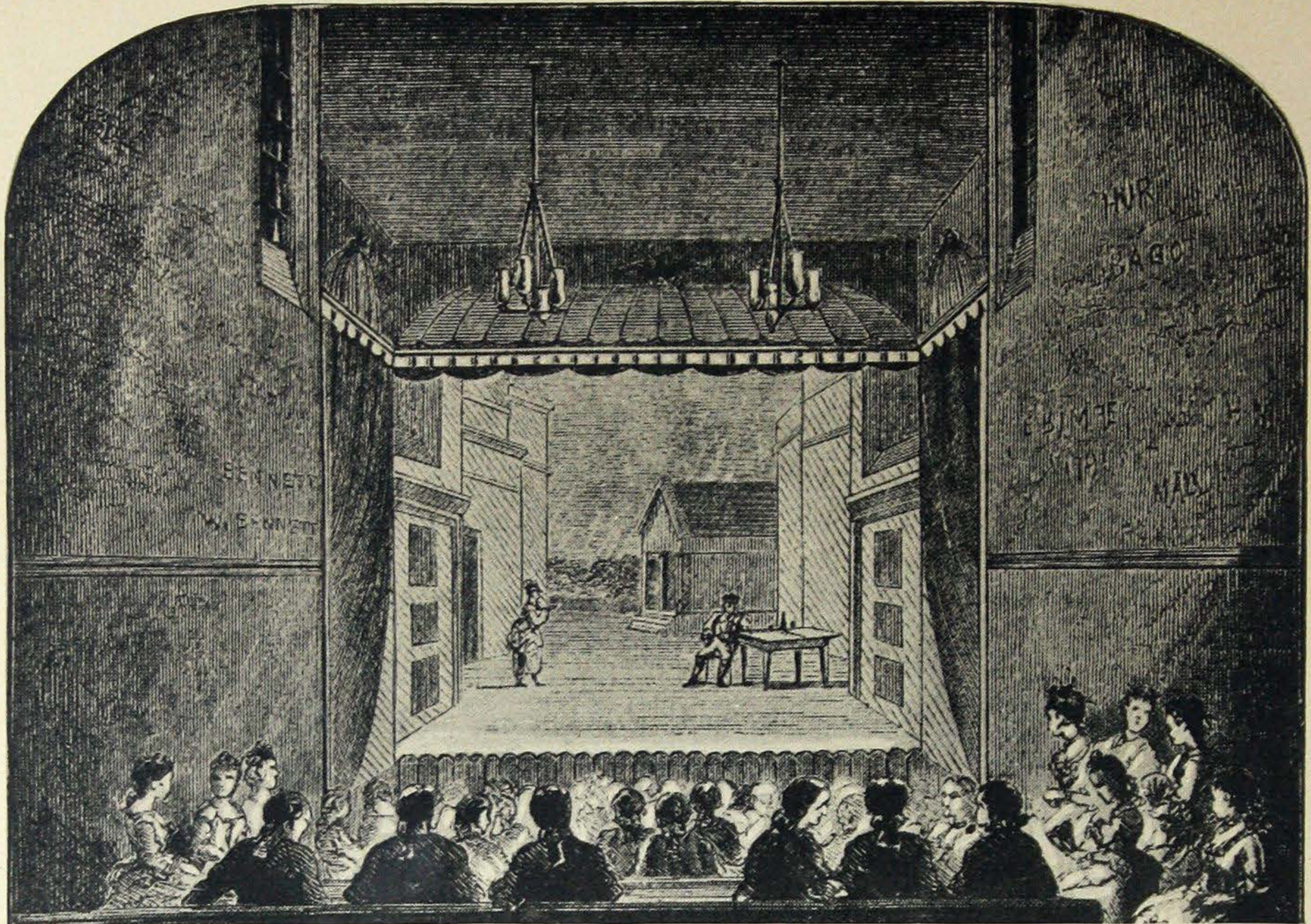
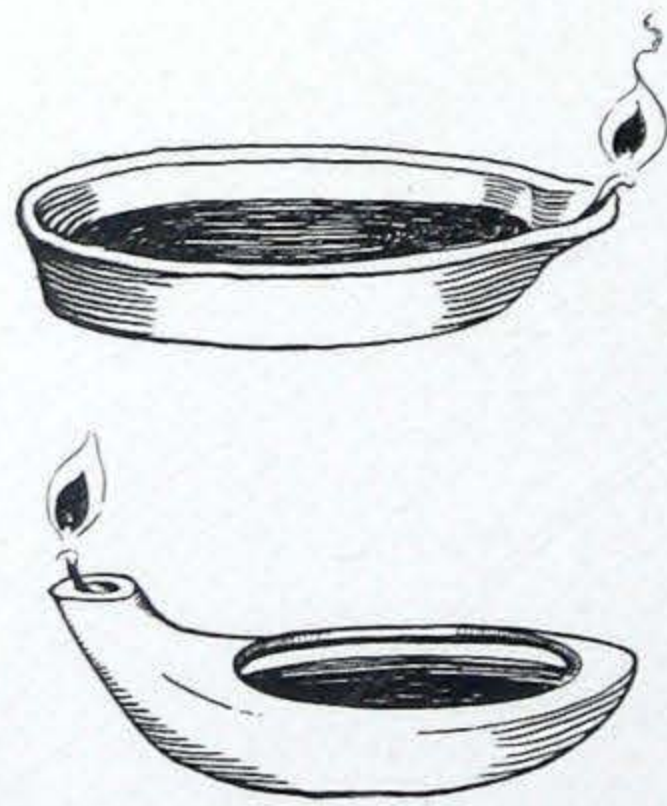

Figure 6—Interior of the famous John Street theatre which was built in 1767 and frequently attended by George Washington. Candles succeeded the open-flame oil lamps in theatre lighting, and the earliest American theatres including this one were lighted by candles. This illustration was taken from Hornblow's History of the Theatre in America.

evening. The stage and interior were illuminated by cressets, lanterns and candles. Stage lighting became of greater importance, and the possibilities of scenic illusions were soon to claim the attention of theatrical managers.

At this time the chief sources of artificial illumination were the same as they had been for thousands of years previous. Torches made of pine knots,



OPEN-FLAME oil lamps in which the wick floated in the oil were used in pre-historic times. Lamps of this type are found in ruins dating back to 7000 and 8000 years B. C.

crude forms of lamps which burned animal or vegetable oil, and candles of wax or tallow comprised the complete assortment of artificial illuminants—the same smoking inefficient means for producing light that had been used by the Greeks, Romans and early Christians.

FOOTLIGHTS

Although David Garrick in London is given credit for intro-

ducing footlights in 1755 when he placed a row of candles below and in front of the stage and masked them by metal screens, it is a fact that footlights were introduced much earlier than this. For instance, Joseph Furtenbach in Germany wrote in 1628 giving specifications for a stage which

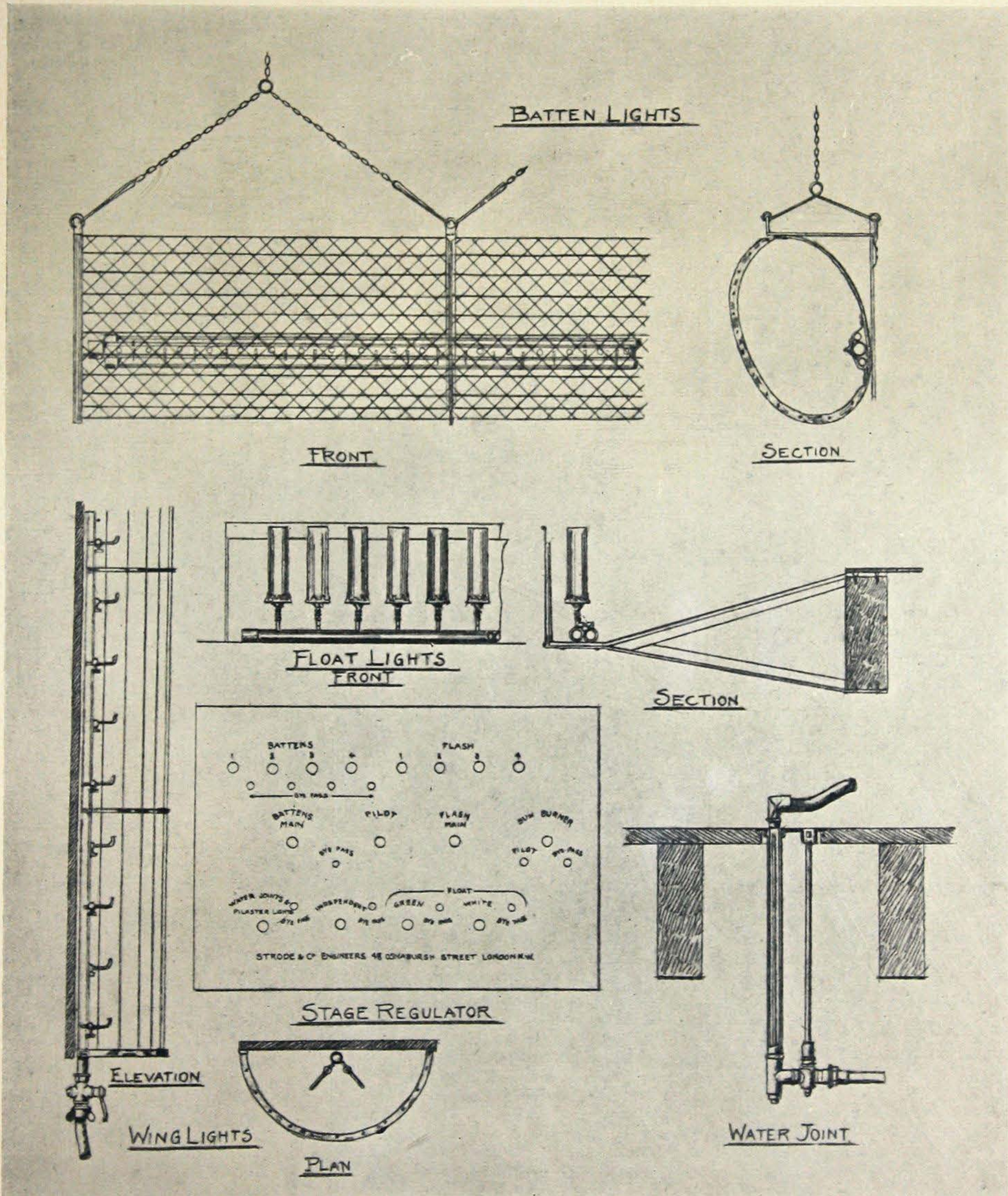

Figure 7—Details of gas lighting equipment taken from *Building News*, October 1894. This illustration shows construction of batten lights, wing lights and footlights, and indicates layout of control board from which the dimming and brightening of the lights was manipulated.

provided footlights. According to his description the stage was a platform inclined toward the audience. In front of the stage there was a place for the orchestra, behind which was erected a wall to screen the musicians from the spectators. A row of oil lamps on the stage side of the wall furnished the footlights. There were wings on each side of the stage—in these wings rows of oil lamps were hung. The rough sketch in Figure 4 gives the ideas set forth in his description which unfortunately was not illustrated. David Garrick also used invisible side lights as described by Furtenbach. These lights are now known as "borders."

Furtenbach speaks of using candles or oil lamps but seems to prefer oil lamps. In Garrick's time the entire stage was lighted by candles, two or more groups were hung in the form of a corona above the stage, footlights were placed in front and invisible lights on either side. The object was simply the illumination of the players. The artistic value of stage lighting had not yet been evolved.

The amusing thing about the descriptions of theatre lighting systems from earliest times is that all writers proclaim the lighting system as giving brilliant illumination. Candles and oil lamps are all described in the same glowing terms in the

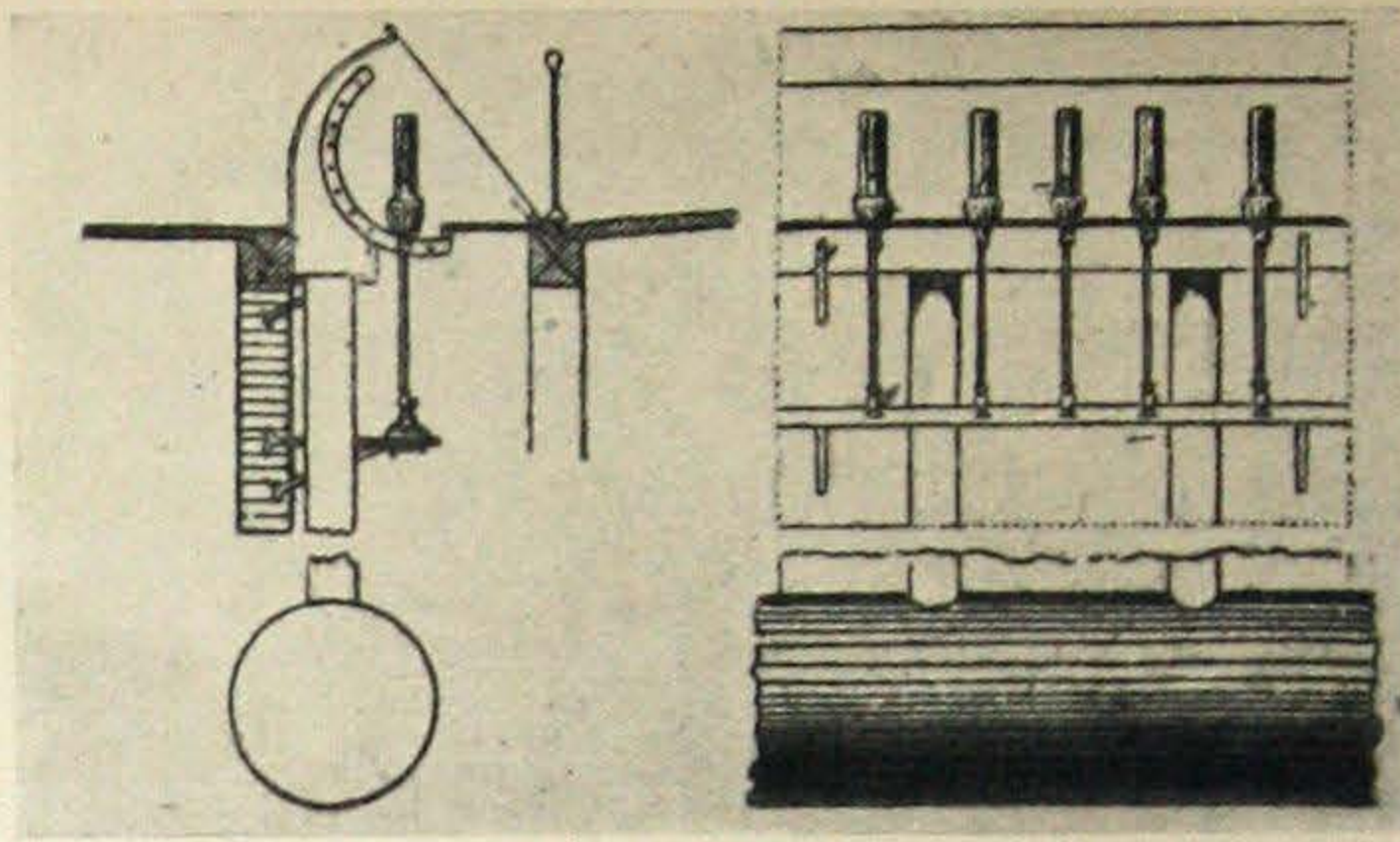

Figure 8—Detail of footlight construction showing reflectors, gas lamps, feed piping and arrangements for carrying away smoke and products of combustion.

early days of their application.

EARLY AMERICAN STAGE LIGHTING

The early theatres of America used the same crude methods of lighting the stage and auditorium that was then in vogue in Europe. The historic John Street theatre, erected in 1767, and New York's leading playhouse for thirty years, was lighted by candles.

To keep the candles burning brightly it was necessary to trim the wicks. One or more attendants were assigned

the task of caring for the lights. Probably it was not an unusual occurrence if a diminution of lighting necessitated their making a round of the footlights during a tense scene of action upon the stage.

Somewhat better systems of oil illumination gradually developed. Lamps with glass chimneys were devised. More efficient lighting was obtainable by the use of cam-



THE tallow candle followed the open-flame lamp, dating from the first century. In the theatre, candles were usually protected by shades which served the double purpose of guarding the flame from drafts and cutting off the light that would otherwise shine in the faces of the audience.

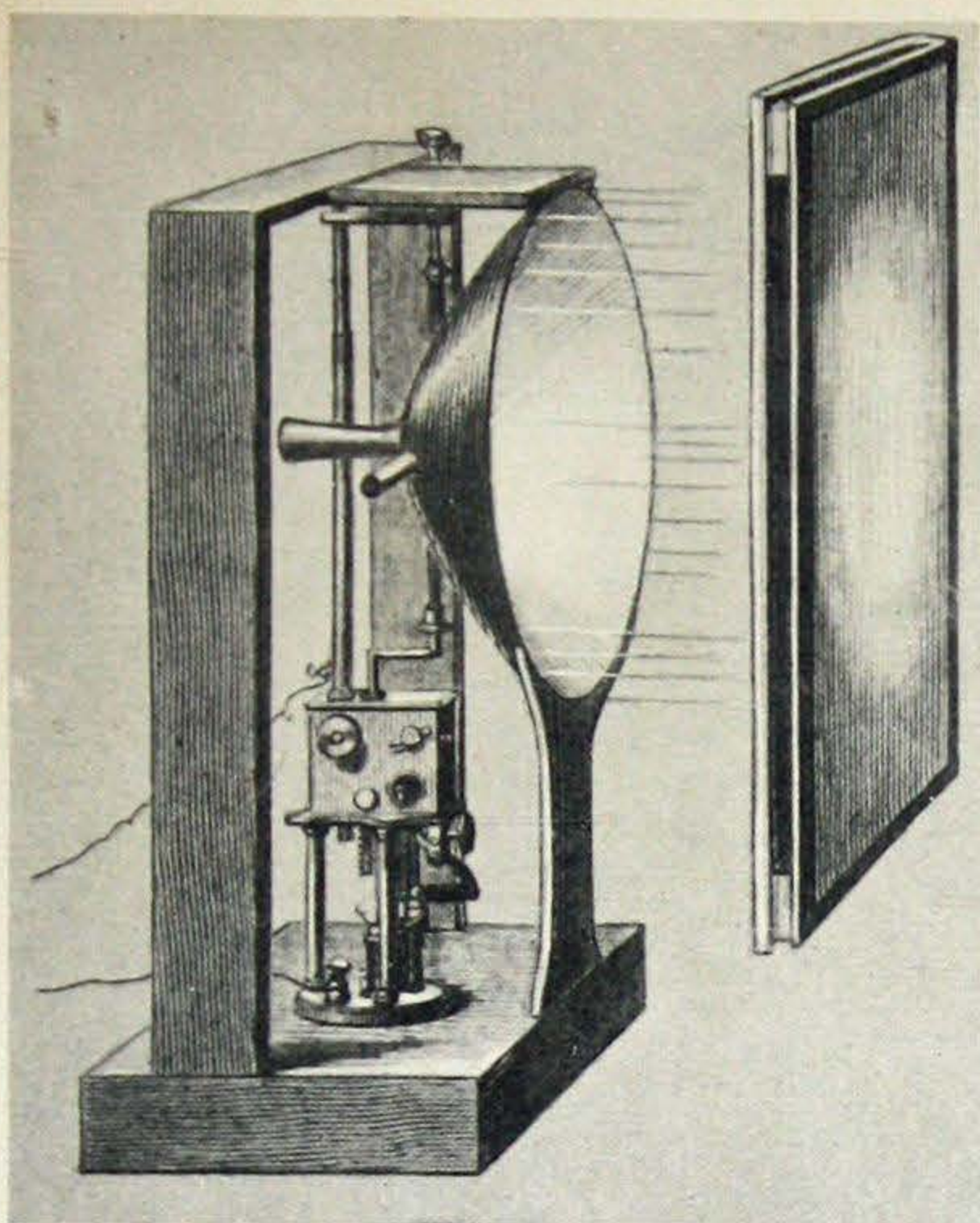

Figure 9—Apparatus used to represent an artificial sun in the production of "The Prophet" in the Paris Opera in 1846. An electric arc was located at the focus of a parabolic mirror and the beam of parallel rays projected upon a silk screen. This was the earliest authentic application of electric light on the stage. This illustration and the six following were taken from *La Lumiere Electrique*, by Emile Alglave and J. Boulard.

phine, kerosene oil and other high-grade illuminants. These new developments supplanted candles and other means of lighting in the theatres. It was a common sight to see hundreds of oil lamps burning. They hung in clusters from the ceilings and projected from the walls, balconies and boxes. They were used on the stage as footlights, as sidelights and were suspended from above. In certain theatres it was customary to hang oil lamps over the stage in front of the curtain line.

Despite the number of lamps used, they threw over the stage only enough light to make the players recognizable. The scenery and properties also remained in semi-obscurity. There was no feasible way of controlling the lights either in the body of the house or on

the stage. Attempts were made to show the changes from night to day and vice versa by the mechanical interposition of screens. This crude method was very unsatisfactory but nothing better was known and the spectators were content. It was not a rare occurrence for one or more lamp chimneys to break in the footlights, or other parts of the house, and a dense black cloud of smoke to rise interfering with vision of the spectators and poisoning the atmosphere. When critical persons expressed displeasure, others reminded them of the tallow candles with which the theatregoers once had to be satisfied, and of the nuisance of having snuffers perform their functions in the midst of a tense situation.

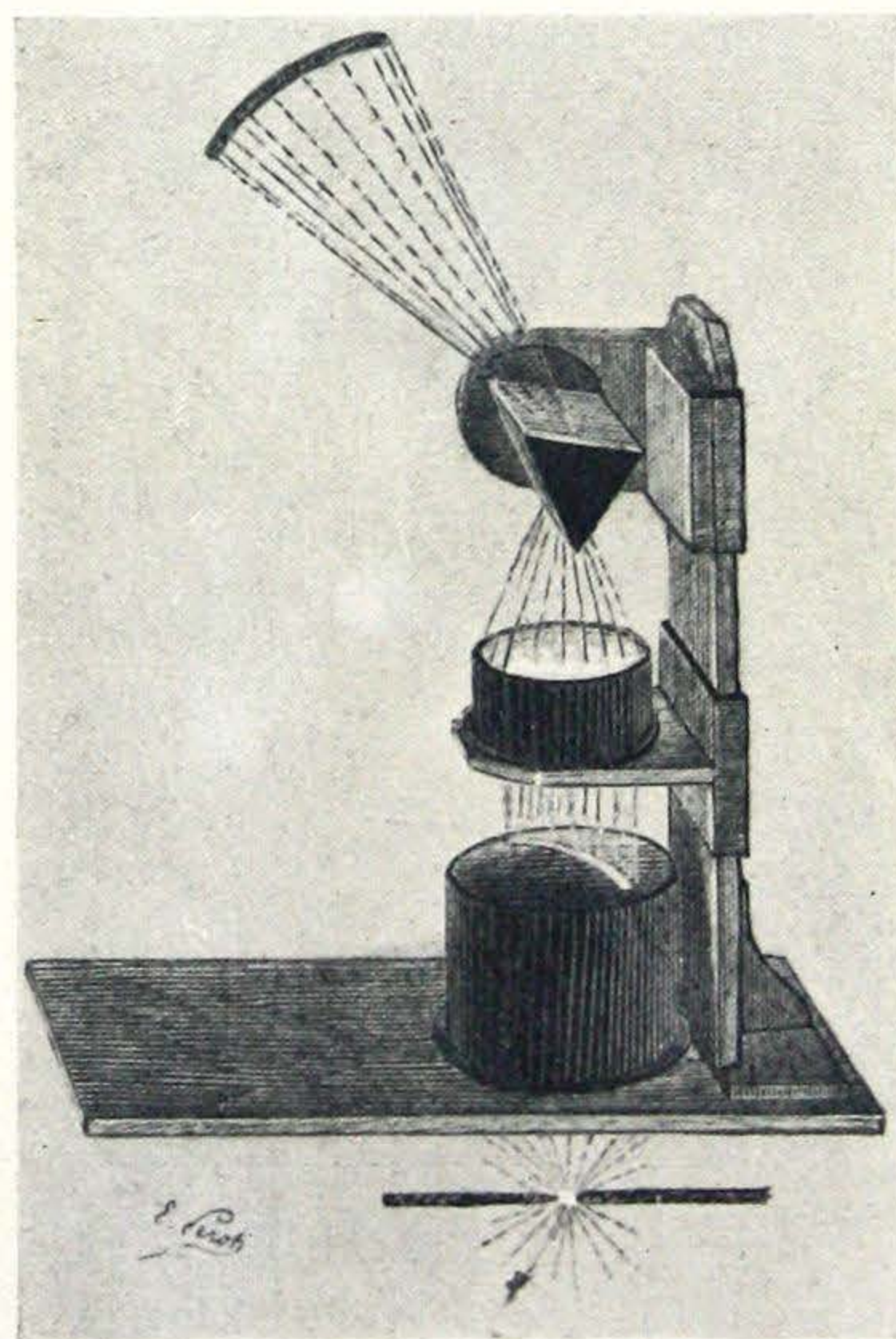

Figure 10—The second important development in electric scenic effects was the representation of a rainbow by means of the apparatus here shown. This device was used in the production of "Moses" in the Paris Opera in 1860. Light from an arc was passed through an arc-shaped slot, after which the rays were concentrated by means of a lens and passed through a prism which produced the spectrum.



Figure 11—The scene in the Opera "Moses" in which the rainbow was produced as explained in Figure 10.

GAS LIGHTING

Then a new era dawned in the history of stage lighting. Gas developments made possible scenic effects that were miracles in comparison to those of the daylight, candle light and oil light periods.

A method for making gas in sufficient quantities to be used for illuminating purposes was devised in 1781, by Mr. Wm. Murdock, an English engineer. In London, in 1803, Frederick Albert Windsor tried the experi-

ment of lighting the stage of the Lyceum theatre with gas. This form

of lighting was introduced into America at Philadelphia in 1796, where it was used for purposes of exterior decoration. In the year 1816, a system of gas lighting was installed in the Chestnut Street Opera House, Philadelphia. There were no municipal gas plants with large street mains and radiating feeder pipes at this time. It was necessary for theatre managers, who desired



AFTER the candle in domestic lighting, came the open-flame camphine burner, which consisted of one or more round wicks inserted into a vessel of clean-burning camphine oil.

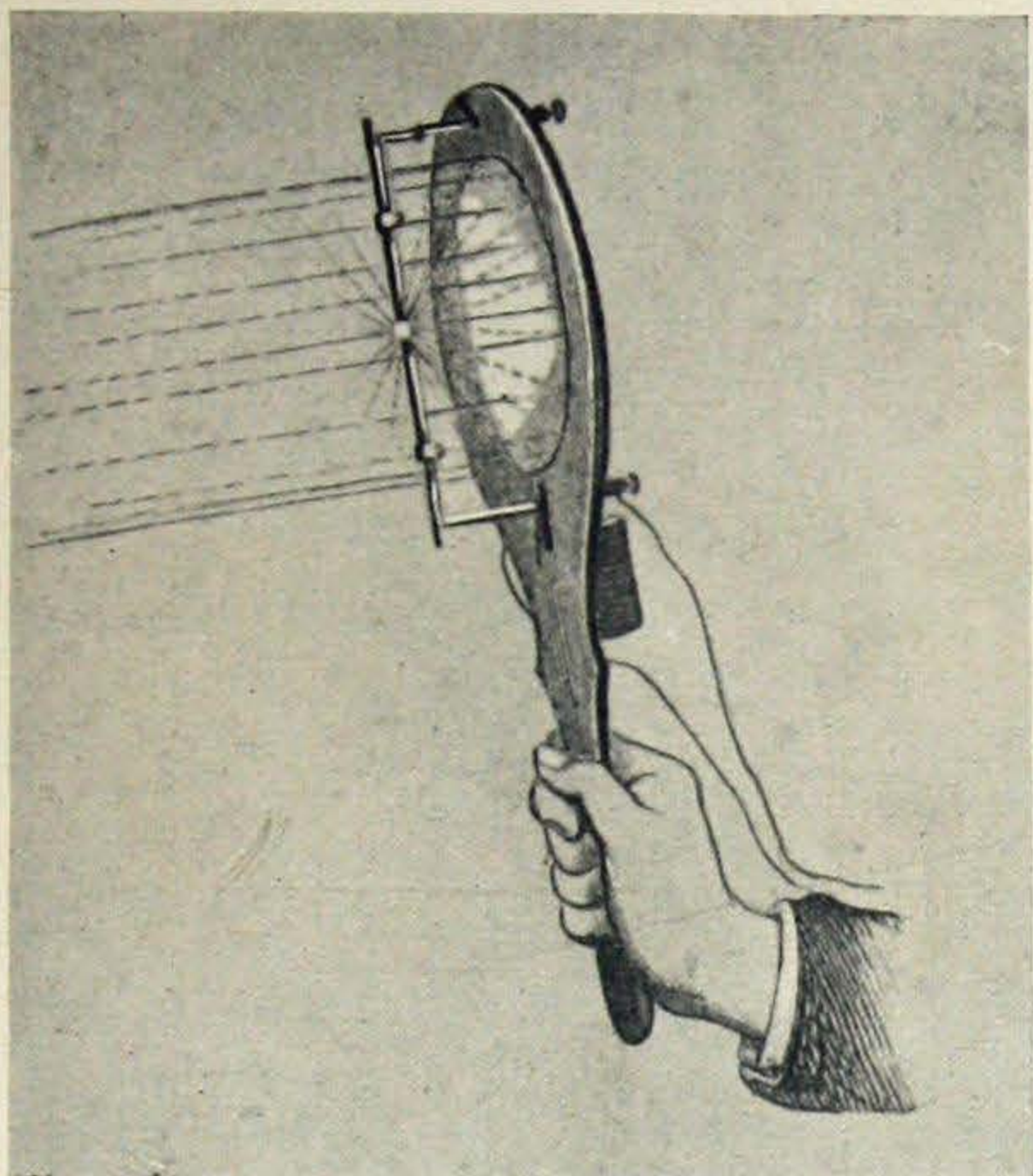

Figure 12—Realistic lightning was produced in the Paris Opera in 1860 by means of a so-called magic mirror, which consisted of a parabolic mirror with an electric arc at the focus. An electro-magnet operated by a thumb switch permitted the carbon electrodes of the arc to be snapped together at will, thus producing flashes like lightning.

to install illuminating gas, to arrange for its manufacture on their premises. At first the methods of manufacture and control were rough and improvised,

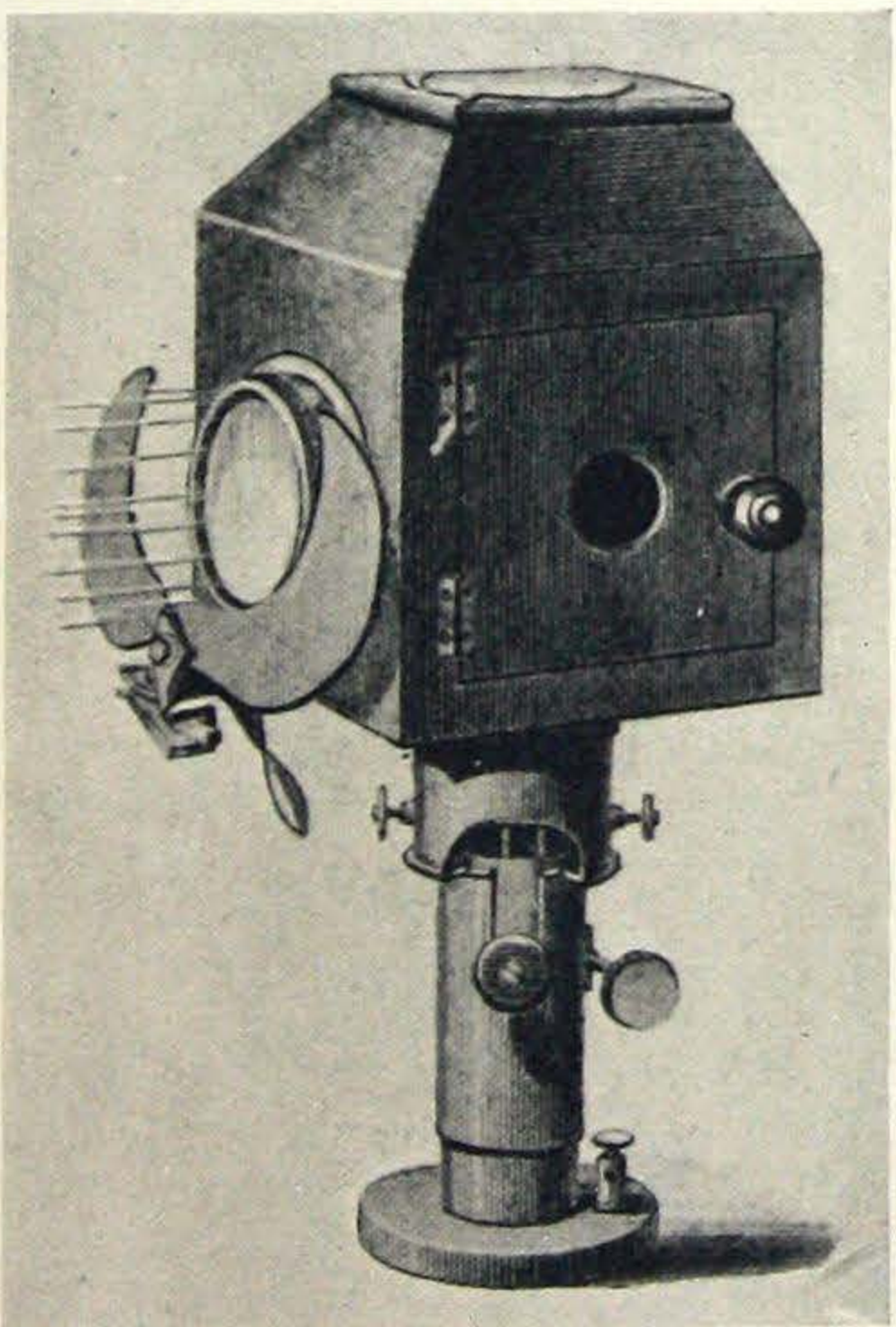

Figure 13—The first electric spot light was apparently the one here shown. It was employed in the Paris Opera in connection with the production of "Moses" in 1860.

and though gas provided more illumination than candles or oil lamps it did not come into general use until about 1850.

LIGHT CONTROL

The value of gas lighting in the theatre was due, not so much to its greater illuminating power, as to its being subject to regulation and control. The new system and its development was a revelation to the public. Auditoriums

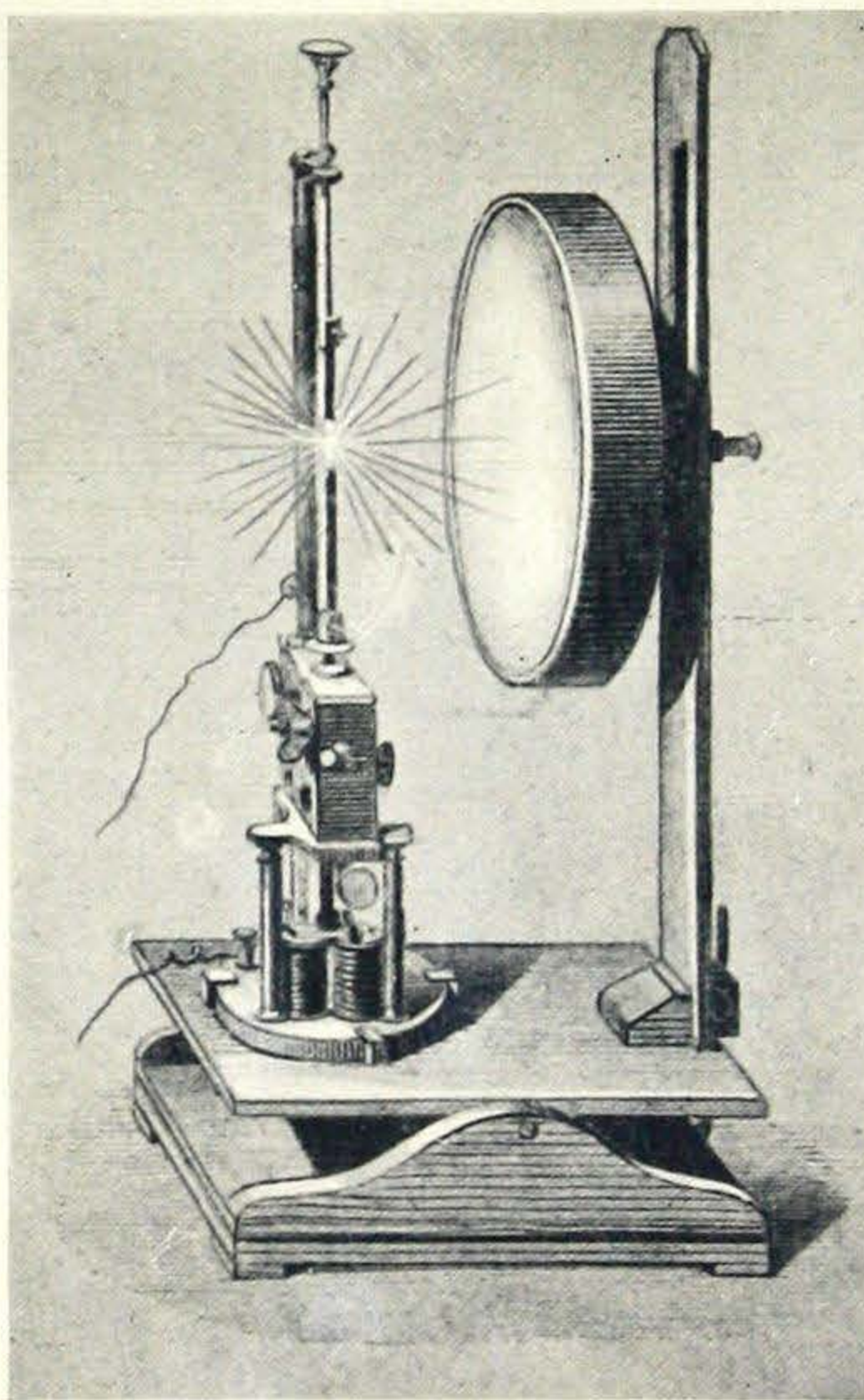

Figure 14—The lamp here shown is a special spot light intended for lighting a definite point in the scene, but not for following the movements of the players. It consists of an arc lamp located at the focus of a parabolic mirror.

were darkened during the action of the play—an improvement heretofore impossible. It was found that darkness and shadow, under control were equally as important factors as light in producing effects.

Elaborate lighting systems were devised. Mains sometimes more than 12 inches in diameter were used and

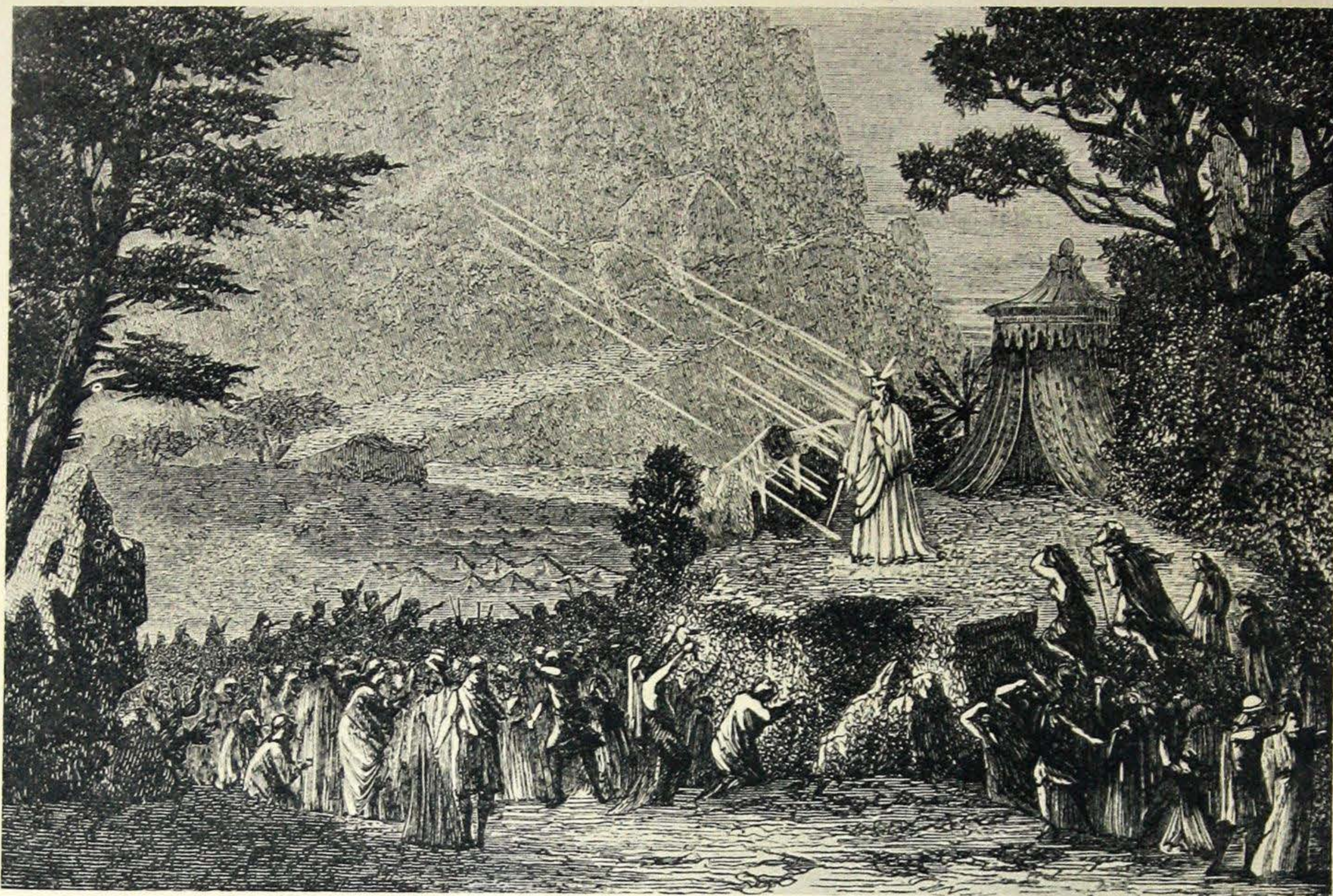

Figure 15—Scene in the Opera "Moses" in which a spot light was used to bring out Moses in his white robes. This scene was particularly effective as the contrast between Moses and his surroundings appeared little short of miraculous; electric light being very little known and spotlight never having been previously used.

many thousands of feet of feeder pipe, fixed and flexible, were installed. The Lyceum theatre at London, and the Boston theatre in America were two of the first to be completely equipped and so arranged that the lights were controlled from one point in the building. A regulator located near the "prompter" was employed for the purpose.

Open-flame gas lights were used at first, and later glass chimneys were added to protect the flame from air currents. It was the

general custom to turn the gas flames low in the auditorium rather than out;

because methods that had been invented for lighting the gas were generally so imperfect that a considerable amount of gas escaped and contaminated the atmosphere before all the jets would ignite. However, changes from "full on" to "dark out" were occasionally considered necessary on the stage itself during the play, and were therefore made even at the risk of fire.

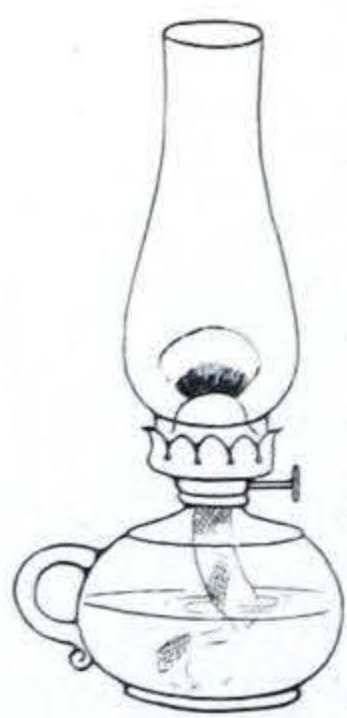

THE kerosene lamp with an adjustable wick was invented in 1783 in France. The glass chimney quickly followed. It was many years before it came into general use.

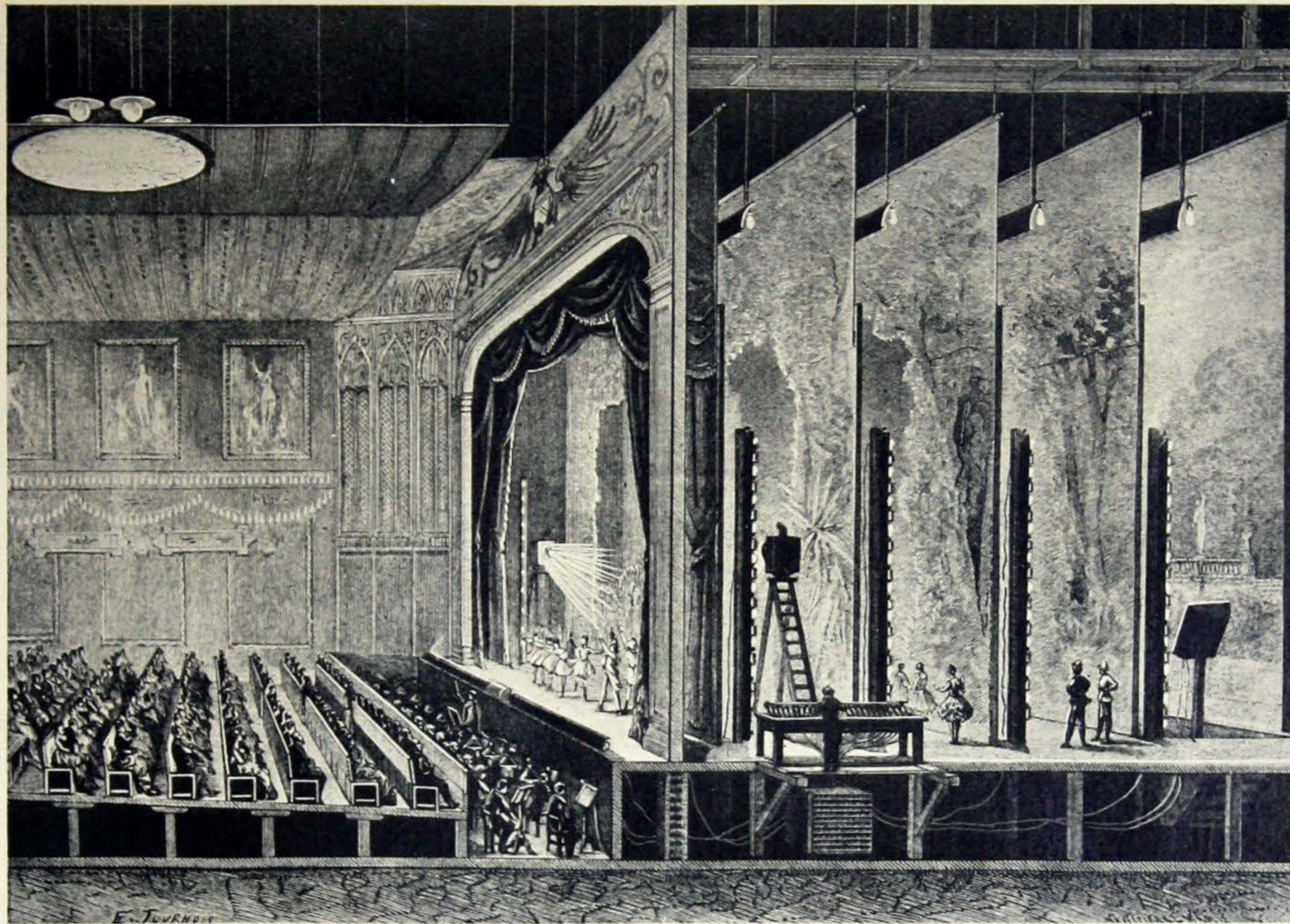

Figure 16—Cross-section of electrically lighted theatre constructed in Munich for the International Electro-Technical Exposition in 1882. This was a remarkable installation which inspired theatrical managers all over the world. It will be noted that arc lamps are used in the auditorium—the lamps themselves being invisible and their light transmitted through a skylight—a system of lighting which is still popular. The electrician who operates the dimmer may be seen at the side, his dimmer being located on the floor below. Footlights, battens, wing lights and bunch lights are all shown in action. This illustration and the six following, were taken from *La Lumiere Electrique*, August, 1883.

ILLUMINATION BY LIME LIGHTS

During this same period another form of illumination was developed that was destined to be of great value in stage lighting. Henry Drummond in 1816 discovered that by raising a piece of lime to a high temperature, it became incandescent and gave out a brilliant white light. This calcium or lime light, as it was called, came into general use for stage illumination about 1860. It was produced by playing a burning mixture of oxygen and hydrogen, upon a block of lime. The light was so concentrated and localized that it was soon adopted for use as a spot light to follow

the hero or some other character about the stage. It also aided the imagination in such effects as light shining through a window, moon light, sun rays and the like. In some cases lime lights were used for the general illumination of the stage, a number of lamps being set at different points throughout the body of the house, and their rays directed upon the stage.

The principle of the lime light once understood led to the invention and development of incandescent gas mantles, which increased the lighting value of gas many fold. Such mantle burners were introduced on the stage for foot-

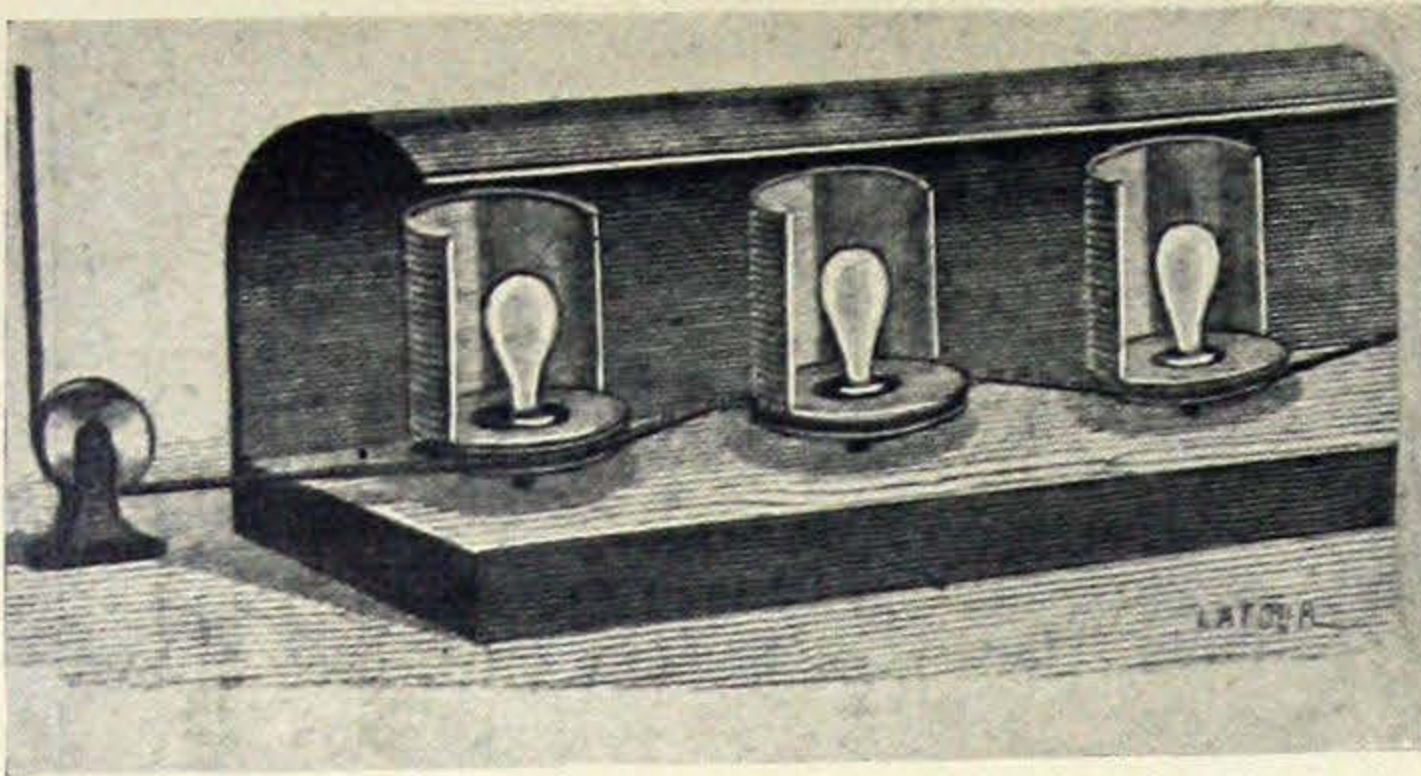

Figure 17—Detail of footlights shown in Figure 16. These lamps were connected with a dimmer for regulation of intensity. Change in color was also provided by mechanical means, each lamp being fitted with a revolving screen, one section of which gave the natural light, the two other sections being blue and red respectively. The change from one color to the next was made by pulling a cord so connected as to turn the screens.

lights, proscenium lights, border lights and bunch lights.

COLOR LIGHTING INTRODUCED

Many of the possibilities of effective stage lighting were realized at the time gas lighting was in vogue. Much thought was given to scenic illusions and colored lights were introduced in a simple form. Henry Irving, one of the pioneers in color development, devised an arrangement for drawing thin colored silk or some other transparent material in front of the lights. Occasionally the bull's-eye of the lime light was covered in the same way. General color effects were produced—one dominating color thrown over the stage was usually the limit of the color scheme.

DISADVANTAGES OF GAS

While gas lighting was a great improve-

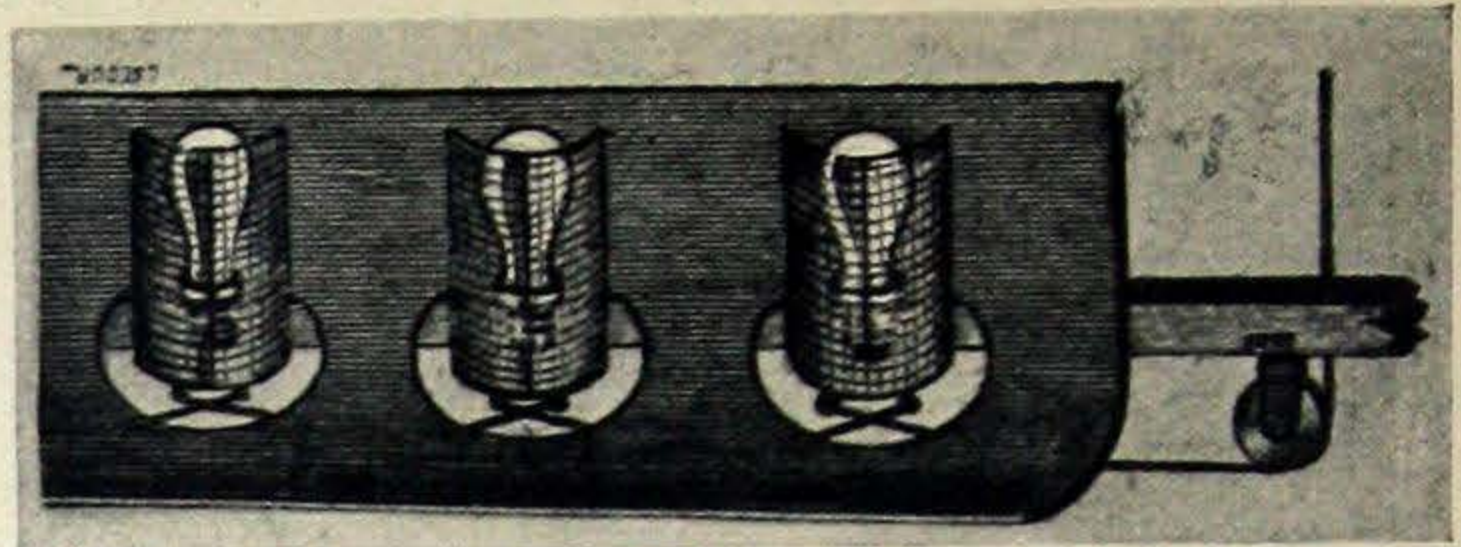
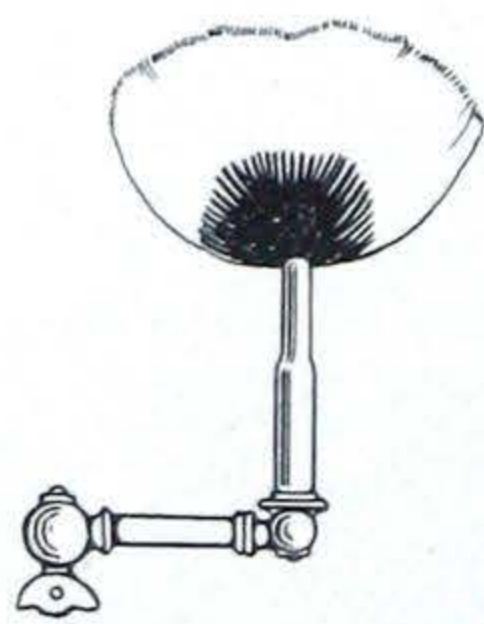

Figure 18—Detail of batten lights shown in Figure 16. These lamps are controlled in the same way as those described in Figure 17.

ment over the earlier forms of illumination, and permitted many spectacular effects theretofore impossible, it possessed serious disadvantages. Stage lighting equipment took up almost as much room as the scenery itself. Rubber tubes trailed in every direction across the stage and wings. The "rising moon," a gas flame back of a transparent yellow disk dragged its gas tube behind as it ascended the scenic heavens, by means of an ingenious system of pulleys. The light of the moon wobbled uncertainly, and the pulleys creaked, still it was somewhat better than earlier representations by means of a lantern mounted on the end of a stick.

Many theatre fires were caused accidentally while lighting the gas by the wobbling among the inflammable scenery of a blazing spirit wad on the end of a long cane.

In an article on the "Lighting of Theatres" which appeared in the "Builder" on August 3, 1861, the writer describes additional disadvantages of gas lighting, as follows:



OPEN-FLAME gas burner was invented in Scotland in 1782. This form of lighting was used wherever the requirements were sufficient to justify the expense of a gas generating and distributing system. One of its earliest uses was in the theatre.

“The upper boxes and galleries are oppressively hot, the view of the stage is interfered with, and whatever there is of ventilation is chiefly productive of a current from the stage which carries sound up to the ventilator instead of allowing it to pass to the audience. As regards the float (footlights) the danger for dancers is considerable as shown by sad accidents. The obstruction not only by the reflectors but also by the visible smoke is great, while the heated air is unfavorable in every respect to the actors and their efforts, and the light dazzles their eyes.”

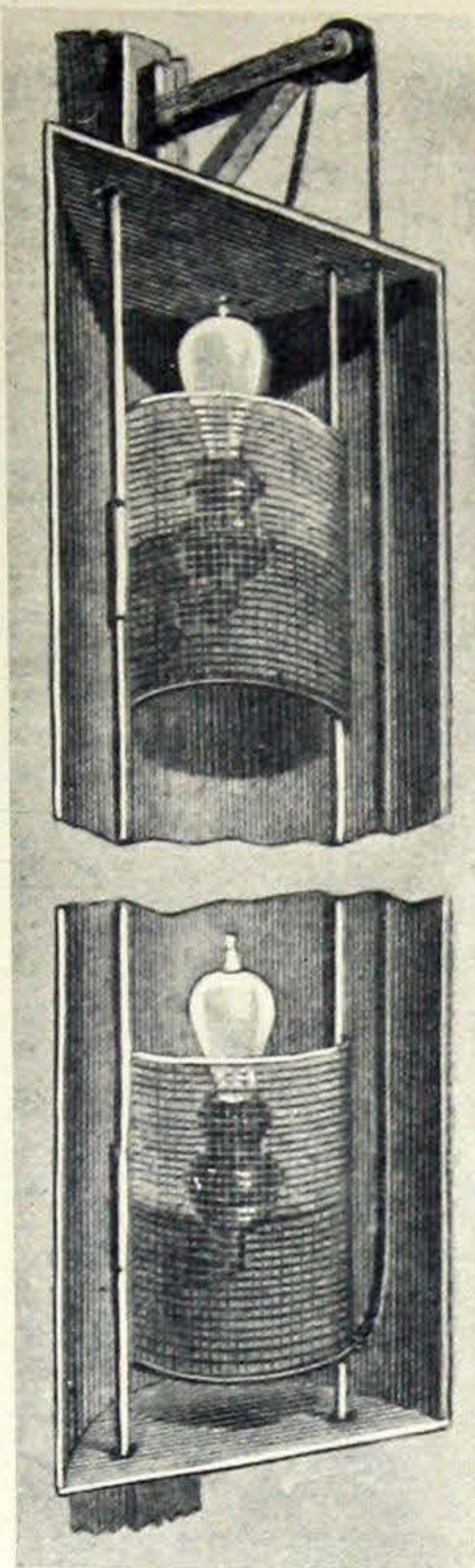

Figure 19—Detail of wing lights shown in Figure 16. The color of the light from these lamps was changed by hoisting and lowering color screens. Like all the other lamps in the theatre, these also were connected to a dimmer.

PROGRESSIVE DEVELOPMENT IN STAGE LIGHTING

In 1808 Sir Humphrey Davy exhibited the first electric arc in England. Some 30 years later the arc came into limited use for special illuminating effects. The earliest arcs were operated with direct current, the arc being formed between two carbon rods connected in an electric circuit; it was started by bringing the tips of the rods together, and then separating them. The light was emitted by the

positive carbon which became white hot at the point where the electricity passed from this carbon to the opposite one. In operation the carbons were slowly consumed and in the beginning frequent adjustment by hand had to be made.

INTRODUCTION OF ELECTRIC LIGHT

The Paris Opera was the cradle of electric stage lighting. In 1846 an astonishing representation of the rising sun was produced by means of an arc placed at the focus of a parabolic reflector and arranged to cast a beam of light on a silk screen (see Figure 9). This device which was used in “The Prophet” was developed by M. J. Duboscq who was a co-worker with Foucault. In 1855, M. Duboscq was

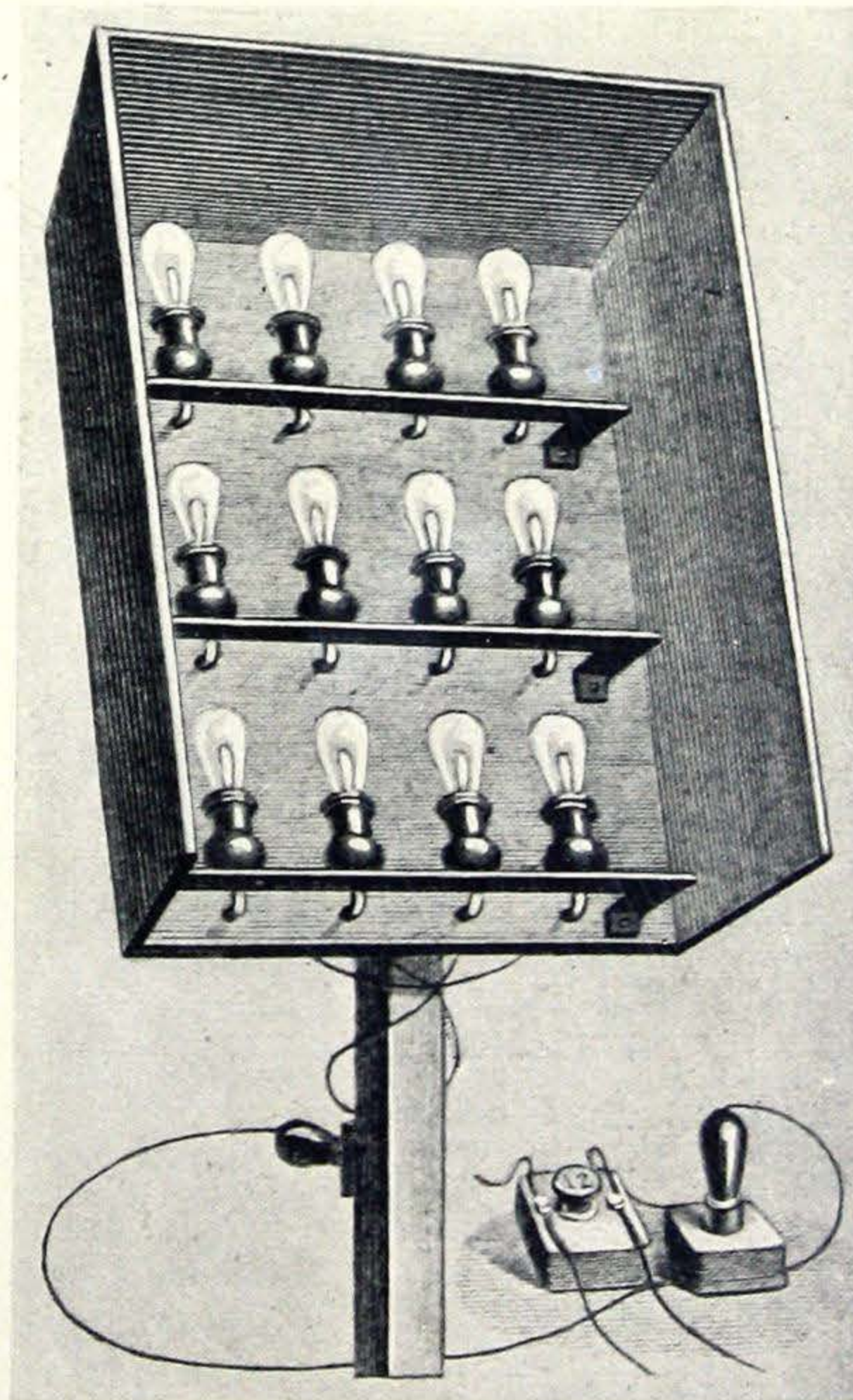

Figure 20—Bunch light for concentrated illumination for certain points in the scene. Its use is illustrated in Figure 16.

permanently retained by the opera, and five years later he developed a number of important contributions to the art of theatre lighting in connection with Rossini's Opera "Moses." Among these effects were the following: A perfect rainbow; lightning flashes and spotlights.

The rainbow was made by passing light from an electric arc through an arc-shaped shutter into a concentrating lens, and from there dispersing the rays according to the spectrum by means of a prism as shown in Figure 10.

Lightning was produced by means of a parabolic mirror at the focus of which an electric arc was located. The arc was flashed on and off by snapping the carbons together. An electro-magnet was used for operating the carbons as shown in Figure 12.

Two forms of spotlight were employed; one with the enclosed arc arranged for manipulation by hand and equipped with shutters which permitted the cutting off of the light at will, and the other with a parabolic reflector back of an arc. The latter was particularly adapted to the illumination of certain spots on the stage, while the former was intended for use in following a performer as he moved about the stage. In this case it was specially intended to illuminate Moses and make his white robes stand out from all the rest.

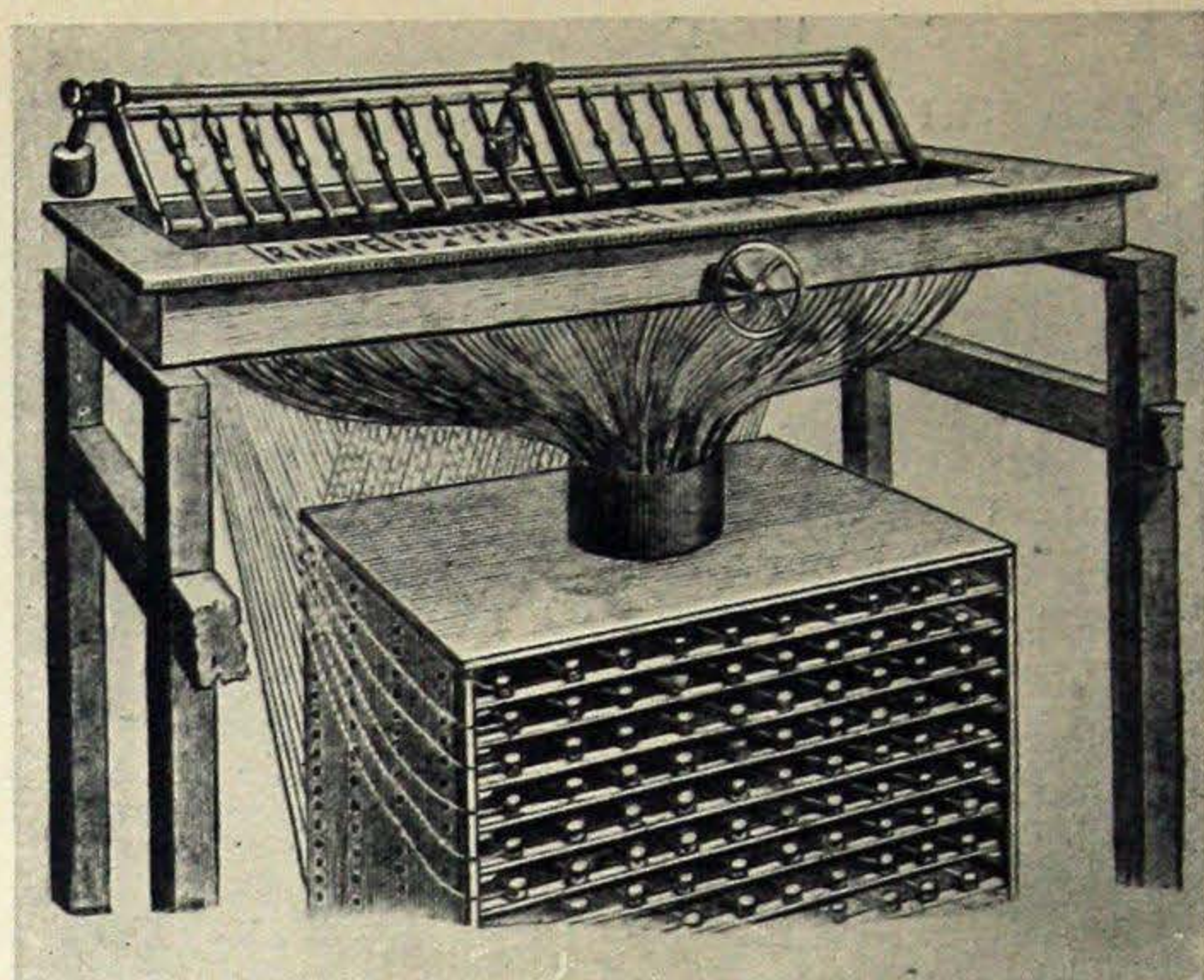
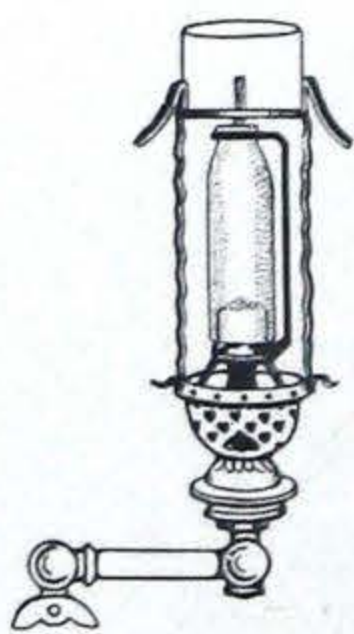

Figure 21—Dimmer rheostat and control board shown in the foreground of Figure 16. It will be noted that this dimmer provides individual control for each rheostat by means of a lever handle. These handles can also be attached to a longitudinal bar which is operated by a slow motion wheel from the front. In this way independent control or interlocked control was obtained.

A luminous fountain was also produced at this time.

JABLOCHKOFF CANDLES

Since the earliest arcs were arranged for hand adjustment of the carbons, they were adapted only for use in lamps that could be personally attended. In 1878 Paul Jablochhoff caused a great sensation in the theatrical world by the introduction of his electric candle, which consisted of two carbon rods mounted side by side and separated by an insulating compound which would melt away, once the arc was started, just fast enough to permit the continuous burning of



THE incandescent mantle in connection with the gas burner, invented in Germany in 1890, was an enormous improvement over the open flame and was quickly adopted by the theatre.

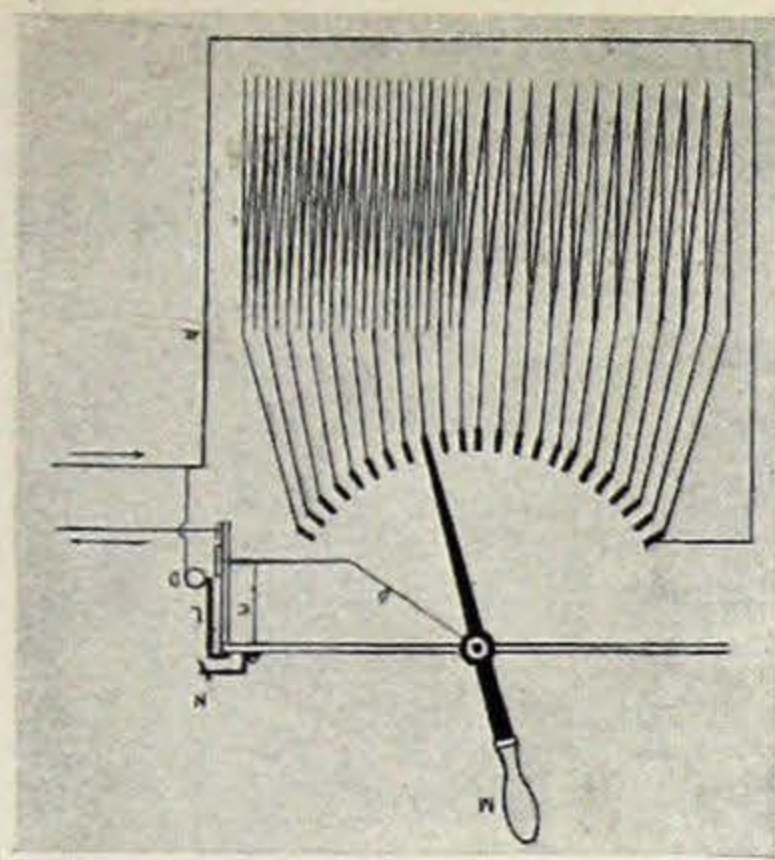

Figure 22—Circuit diagram of open-coil type of dimmer rheostat. From *La Lumiere Electrique*, April, 1884.

the arcs across the upper ends. In 1879 the Bellecour Theatre at Lyons, France, was equipped with 52 of these electric candles, 12 of them being installed on the stage.

Electric lighting with Jablochkoff candles did not come into general use and gas lighting was still the common means of lighting theatres at this time.

INCANDESCENT LAMPS

In 1879 when the Jablochkoff candle was just starting its career in Europe, Edison in America invented his incandescent lamp and this was soon brought into practical form by the contributions of various other inventors. Again the Grand Opera in Paris led the way. The Director, M. Garnier, reported in 1879 to the Minister of Public Works that the vapors from the gas were discoloring and destroying the beautiful paintings of Baudry which hung in the foyer.

The result of this report was a series of experiments with various systems of electric lighting, and these

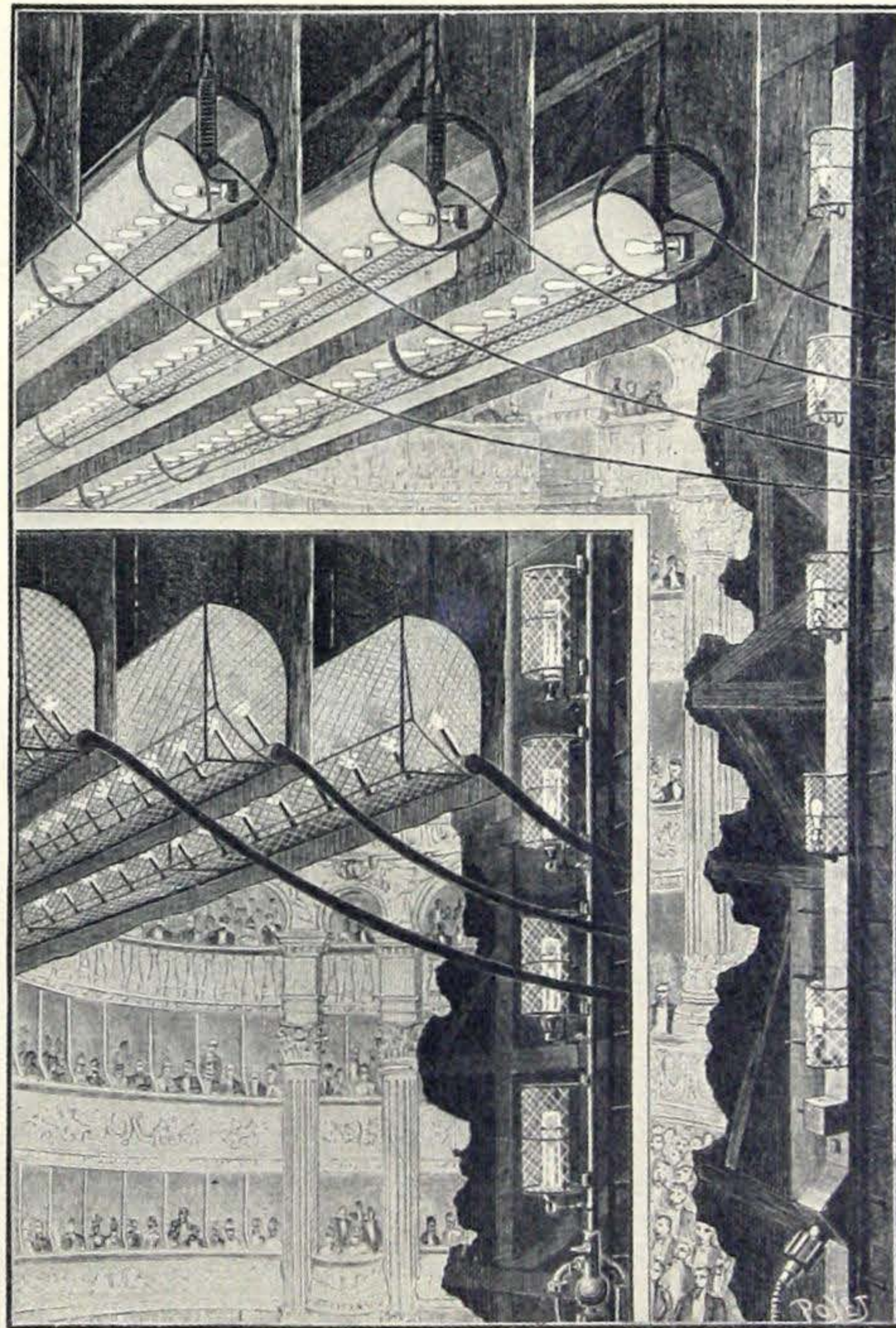
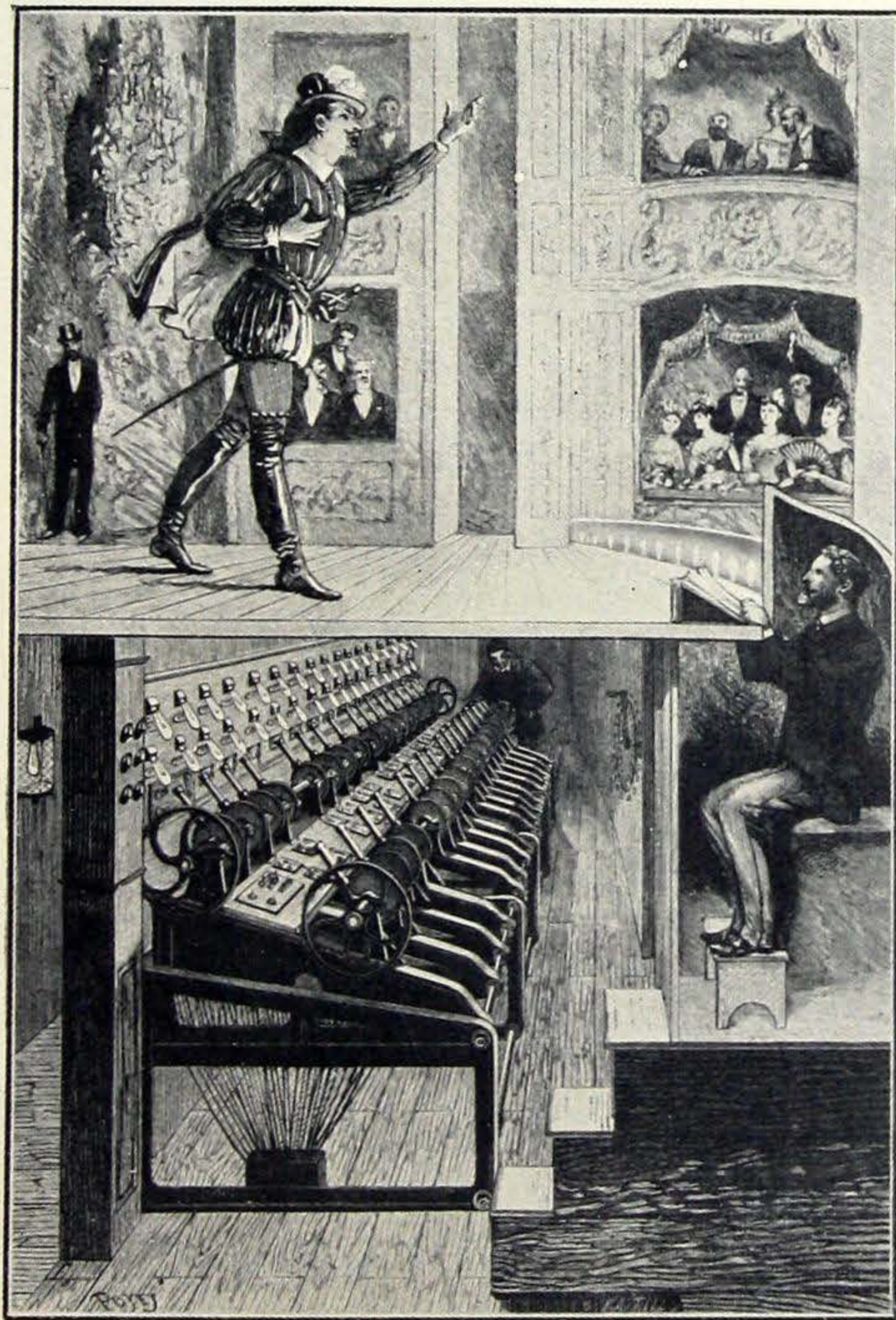

Figure 23—The electric lighting and control system used in the Paris Opera and described in *L'Illustration*, June, 1887. The insert shows the comparison between electric and gas batten lights and wing lights. The dimmers are extremely interesting. It will be noted that the rheostats are mounted below the floor, and the leads brought up to contact buttons, connection to which is manipulated by means of lever arms. These lever arms can be adjusted independently or locked to a master shaft which is operated from the end by hand.

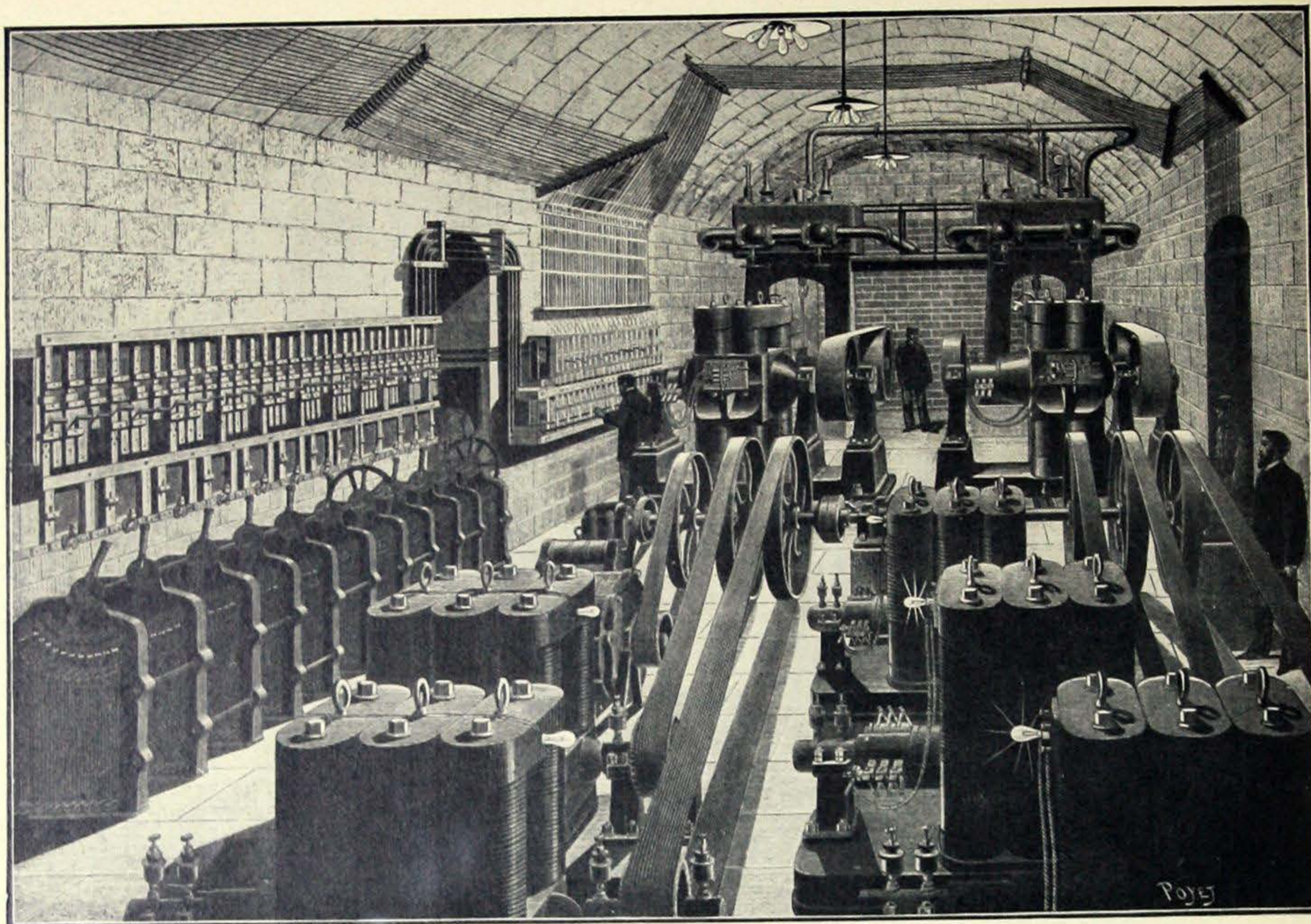
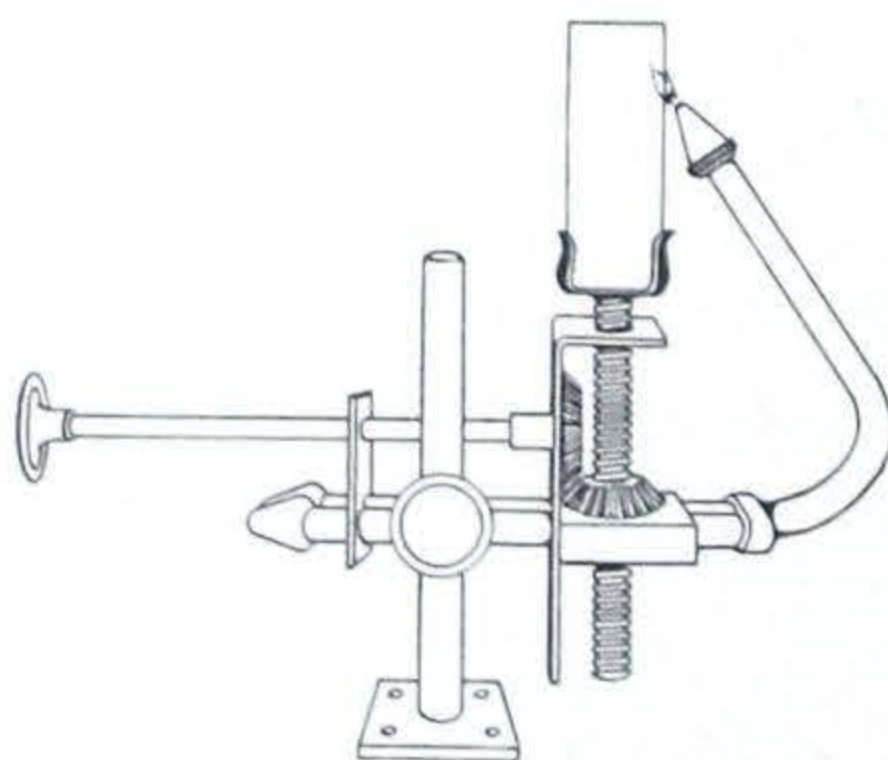

Figure 24—In the early days of electric lighting in theatres, each theatre provided its own electricity. The earliest installations employed batteries. Here is shown the power plant of the Paris Opera, as given in the June, 1887, issue of *L'Illustration*.

tests which were made in 1880 and 1881 constituted the first theatrical installation of incandescent lamps.

MANAGERS FAVOR ELECTRIC LIGHT

Theatre lighting by means of electricity received a tremendous impulse from an exhibit at the Electro-Technical Exposition at Munich in 1882, where a small theatre completely lighted by electricity was erected in the Crystal Palace. This



A BLOCK of lime heated to incandescence by an oxy-hydrogen blow pipe was used for many years as a spot light in the theatre. From this practice the expression to be in the "lime light" originated.

theatre, a cross-section of which is shown in Figure 16, was equipped with both arc and incandescent lamps. A diffused light was used here probably for the first time; a number of arc lamps being suspended above the ceiling and their light transmitted through circular panels of glass ground in ornamental designs. This method of lighting was most effective, since it hid the unsightly lamps



Figure 25—Early Ward Leonard Vitrohm Theatre Dimmer made up of two vitrohms rectangular plate units, connected together and mounted on a panel board which carried a dial switch with an extension lever to permit convenient adjustment. These dimmers were installed in Altmeyer's Theatre, McKeesport, Pa., in 1892.

and produced a wonderfully soft effect due to the diffusion of the light. The walls were illuminated with incandescent lamps arranged to form artistic designs.

The stage was lighted entirely with incandescent electric lamps, arranged with screens that could be mechanically operated to change colors from natural to red or blue. The mechanism by which this was accomplished is shown in Figure 17.

In September, 1882, a Congress of

Theatrical Managers assembled and issued a formal report favoring the lighting of halls and theatres by electricity, then followed the installation of electric lighting in the Savoy Theatre in London in 1882, and the Bijou Theatre in Boston the same year. The first New York theatre to install incandescent lighting was the Peoples Theatre on the Bowery in 1885.

Henry Irving was a pioneer in the art of stage lighting. He made extensive use of the spotlight, which had been first introduced in the Paris Opera, and he accomplished much in the extension of the application of electric lighting to the production of scenic effects. In his production of Faust, he arranged, with Mr. Gourand, a system of circuits for the production of sparks and fire in the fight between Faust and Valentine. Connections to the outside circuits were made through plates on the actor's shoes.

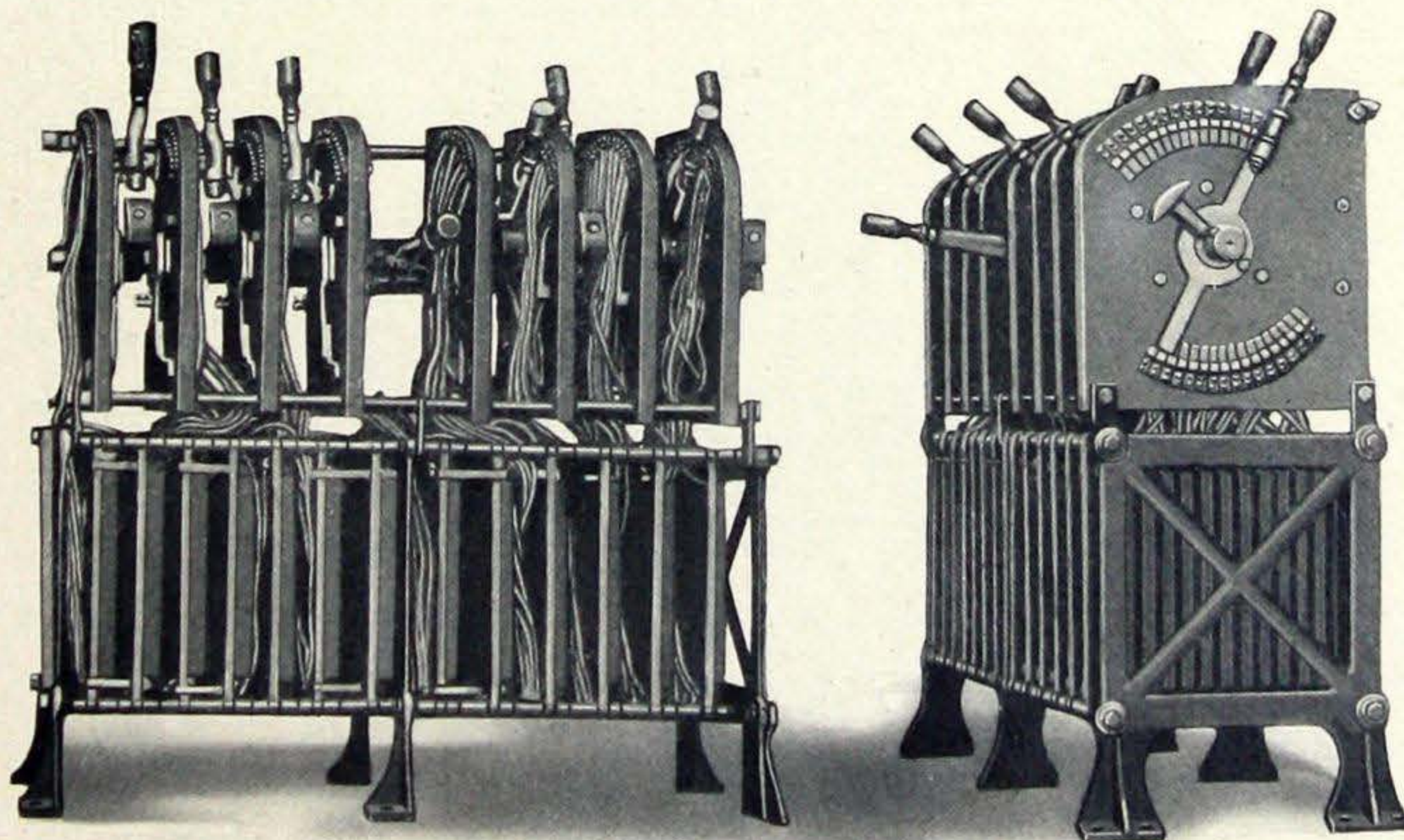

Figure 26—Ward Leonard Theatre Dimmer put on the market in 1894. It consisted of banks of vitrohms rectangular plates mounted in a frame work above which dial switches were arranged. Connections between the contact points on the dial switch and corresponding points in the resistor units were made by means of wires. This was the first step in decreasing the space occupied by a bank of theatre dimmers.

CONTROL OF LIGHTING

The real problem in the application of electric lights to the theatre is not so much the illumination of the stage and auditorium as the proper control of the light. It was not until various devices for regulating electrical current and manipulating the various circuits were invented that electricity was able successfully to supersede gas.

Gas lighting permitted graduation of the illumination of every part of the stage and auditorium from a single control station. This was accomplished by the manipulation of valves in the regulator from which all pipes radiated. The amount of gas flow was increased or decreased by opening or closing the valves, the amount of illumination being varied accordingly.

At the time electric lighting was introduced into theatres, control similar to that available with gas was demanded. Fortunately, the new electric system offered even greater possibilities than the gas, although these possibilities were not immediately realized. Today the refinements of control offer opportunities for the production of scenic effects that have not been as yet completely utilized.

With electricity, the flow may be adjusted by controlling the resistance of the circuit or by controlling the pressure or voltage, of the circuit. In alternating-

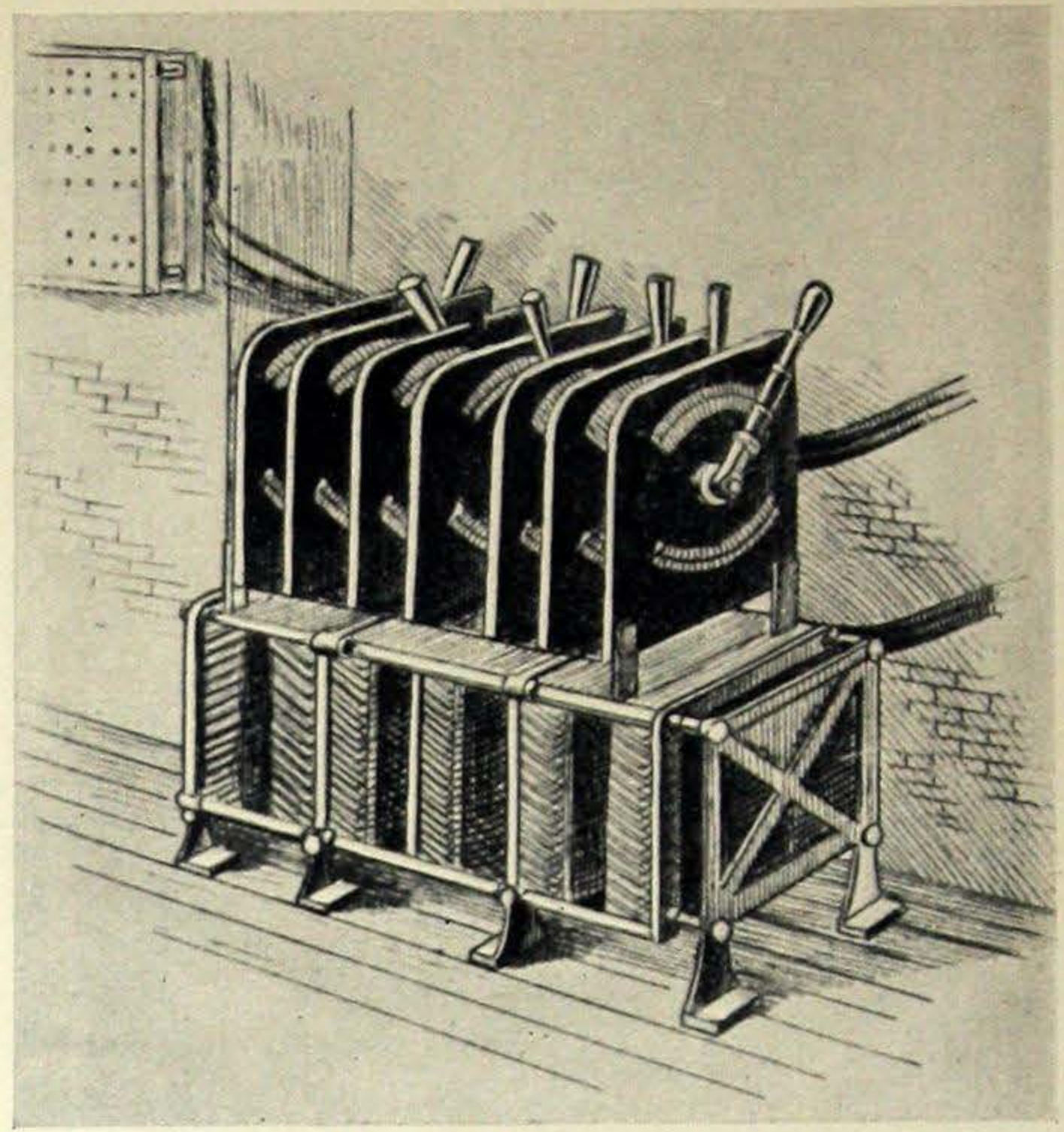
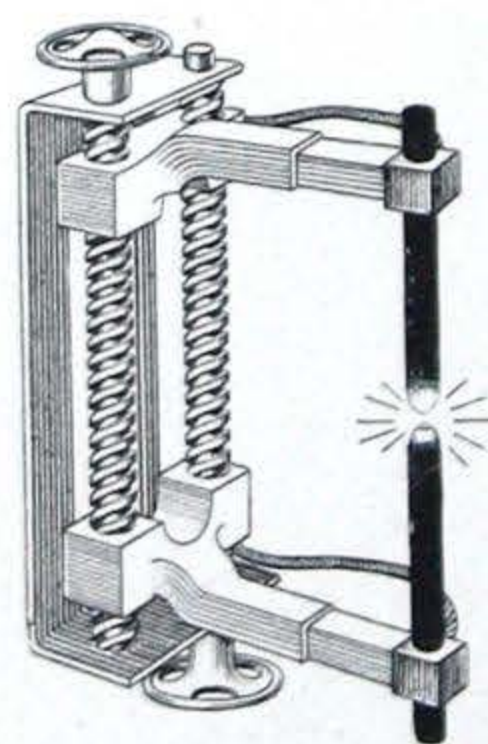

Figure 27—Ward Leonard Dimmers used in the Olympia Theatre in New York in 1896. The small panel board in the background contains relay circuits for the remote control of main-line switches located in different parts of the house. From *The Electrical World*, March 1896.

current systems the flow may also be adjusted by controlling the reactance.

In the beginning, the resistance method alone was used.

A device, the principal characteristic of which is resistance, is called a "resistor" and if it is arranged in such a way that its resistance can be varied or adjusted, it is called a "rheostat". Rheostats are used to vary the flow of electricity through a circuit in the same way that the flow of gas can be varied by partially closing or opening a valve. Rheostats that are used for dimming the light in



IN 1808 Sir Humphrey Davy invented the electric arc. In the forties it came into use on the stage and later superseded the lime light. The earliest lamps provided for adjustment of the carbons by hand.

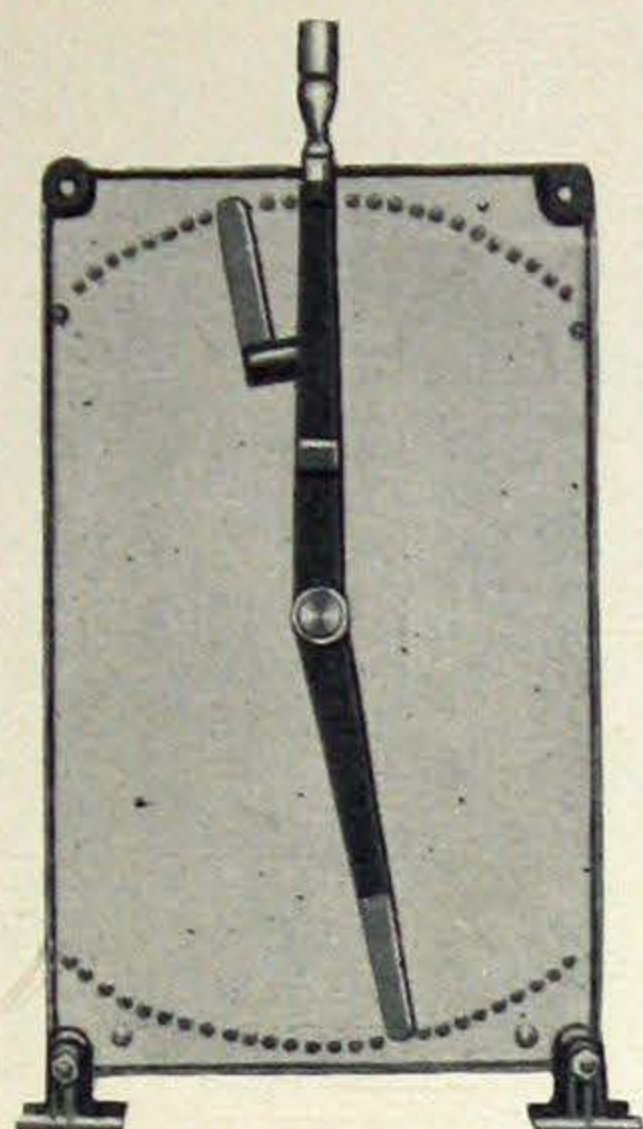

Figure 28—Ward Leonard Plate Dimmer—1897.

a theatre, or other public or private places, are called "dimmers".

THE FIRST ELECTRIC DIMMER

The first dimmers were made by using water-barrel rheostats to increase the resistance and thus reduce the flow of electricity to the lamps. A rheostat of this kind consisted of a barrel filled with water in which two plates or electrodes were immersed. When the plates were tight together there was practically no resistance to the flow of electricity, and the lamps burned with full brightness. When the plates were separated from one another, the electricity was forced to pass through the water which greatly cut down the flow and reduced the brightness of the light. This type of dimmer was short-lived. It was bulky, difficult to keep in working order, the results were never twice alike, and when overloaded it produced vapors which were often disagreeable.

COIL RHEOSTAT DIMMER

The barrel dimmer was followed by the coil rheostat dimmer which consisted of a number of coils of German Silver Wire (a metal having a high resistance) assembled in a rectangular

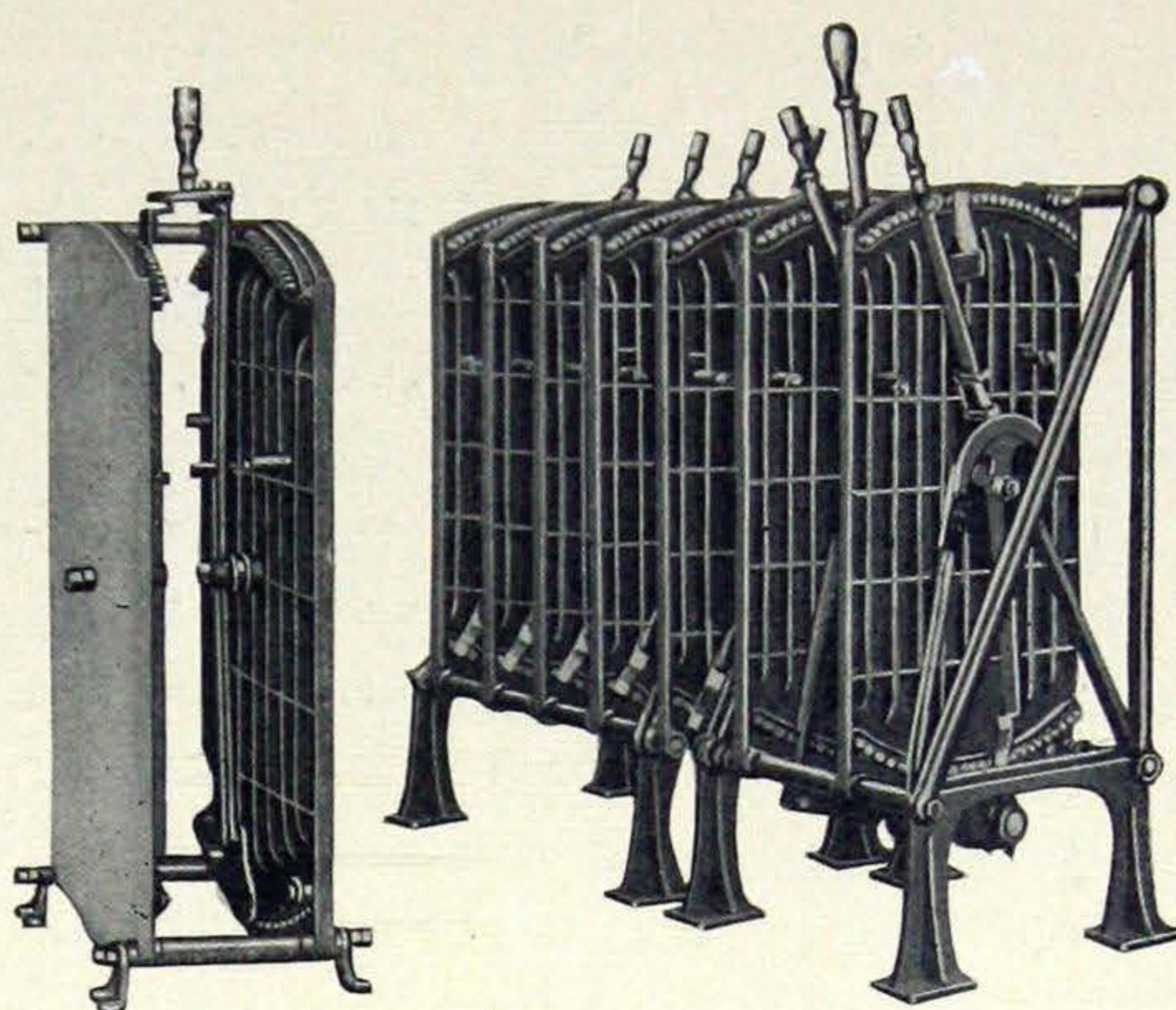

Figure 29—Arrangement of two Ward Leonard dimmer plates with a single operating handle—1897.

Figure 30—Bank of Ward Leonard plate dimmers arranged for individual control, as well as master control. The master lever is between the first and second plates—1897.

frame with wires leading to a dial switch, which permitted, as required, a variation in the number of coils connected in the circuit. The practice was to install the dimmers in the basement below the switchboard and run wires up to contact points on the board. A rough diagram indicating the principle of this dimmer is shown in Figure 21.

Reducing the flow of electricity by introducing resistance into a circuit uses up the energy by transforming it into heat. Therefore, dimmers become hot in use, and their capacity is governed by the amount of heat they can dissipate without attaining a dangerous temperature, and without being injured in the process. Coil rheostat dimmers were unsafe because the coils of resistance wire were dangerously exposed and frequently became red-hot due to overload.

VITROHM DIMMERS

The coil rheostat dimmer was standard practice at the time the Ward

Leonard Vitrohm plate rheostat (Figure 27) with a dial switch was introduced. This new method of construction greatly reduced the space occupied by the rheostat and eliminated fire risk, incident to open-coil construction.

The next important step in the development of dimmers was the Ward Leonard Vitrohm dimmer in which the dial switch and the rheostat proper were combined in one structure, eliminating leads entirely. The contacts or buttons on the dial switch were attached directly to the resistor wire and the whole structure was supported by an iron plate, the electrical circuits being insulated and supported by vitreous enamel.

Modern Ward Leonard dimmers are simply refinements of the original apparatus. They are lighter, more compact and easier to operate but the general principles of construction are the same.

The practical process of imbedding the resistance wire in vitreous enamel and fusing this enamel to an iron supporting plate is covered by Ward Leonard patents, and is denoted by the trade-name "Vitrohm". Ward Leonard dimmers that are constructed with Vitrohm plates are called "Ward Leonard Vitrohm Dimmers".

TRANSFORMER DIMMERS

As was mentioned on page 24, in a.c. circuits it is possible

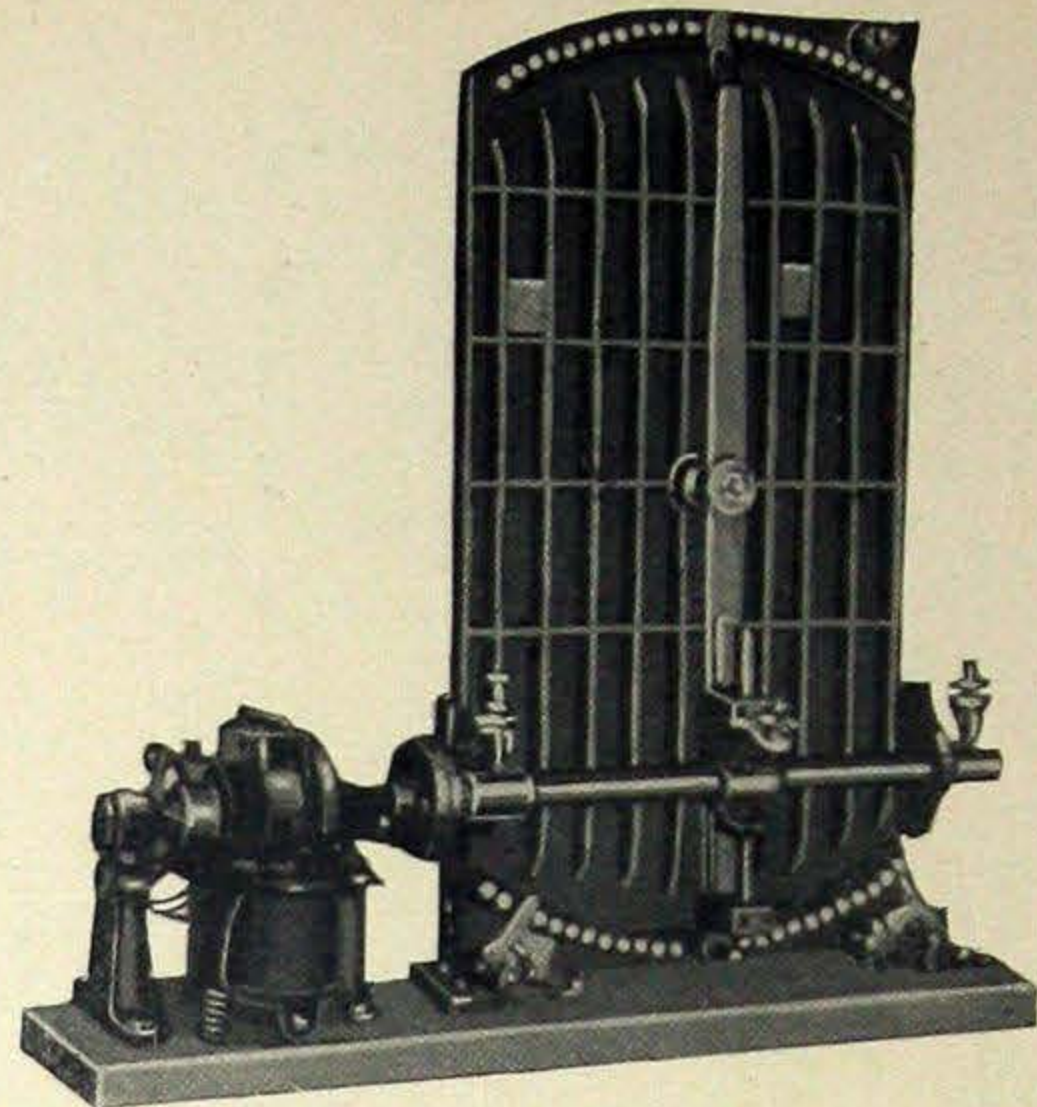

Figure 31—Ward Leonard remote control dimmer operated by three push buttons—1897. This dimmer is still used in the Waldorf-Astoria auditorium.

to vary the flow of electricity by changing the voltage of the circuit or by changing the reactance, both of which systems accomplish the result with less dissipation of energy than the resistance method.

The earliest methods employed transformers in which provision was made for varying the secondary voltage. In the nineties a device of this kind was put into practical use.

One of the earliest ones employed an auto transformer which operated with a combination of variable voltage and variable reactance as shown in Figure 32. A pure reactance method of current variation was used in the Earl's Court Exhibition Theatre in 1896. The details of construction and electrical connection are shown in Figures 32 and 33.

The principle objection to dimmers of the

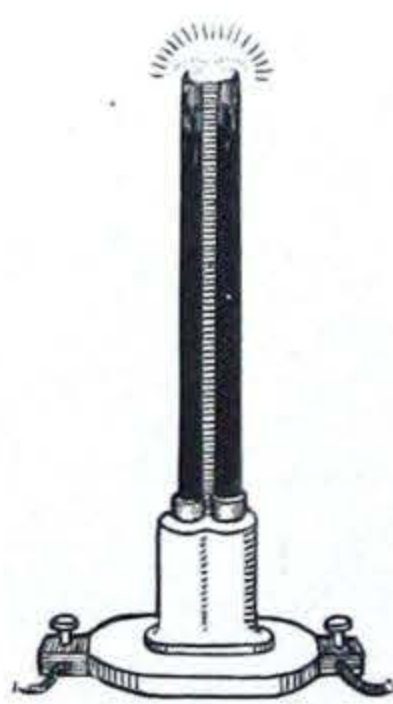

THE first really commercial arc lamp was the so-called Fablochhoff candle, which consisted of two carbon electrodes insulated from each other by material that was broken down and consumed by the arc as the electrodes wore away from the action of the arc.

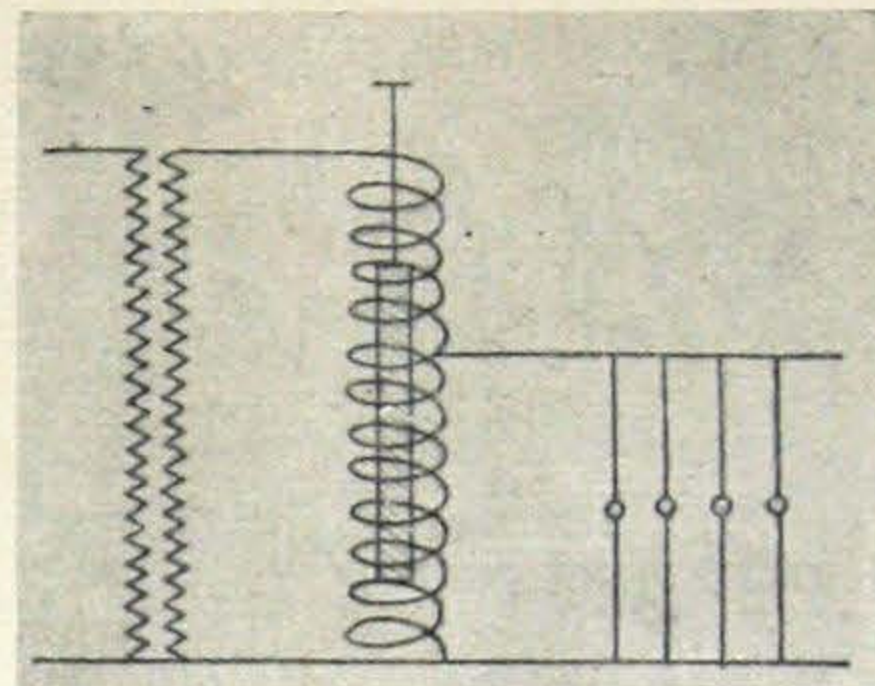
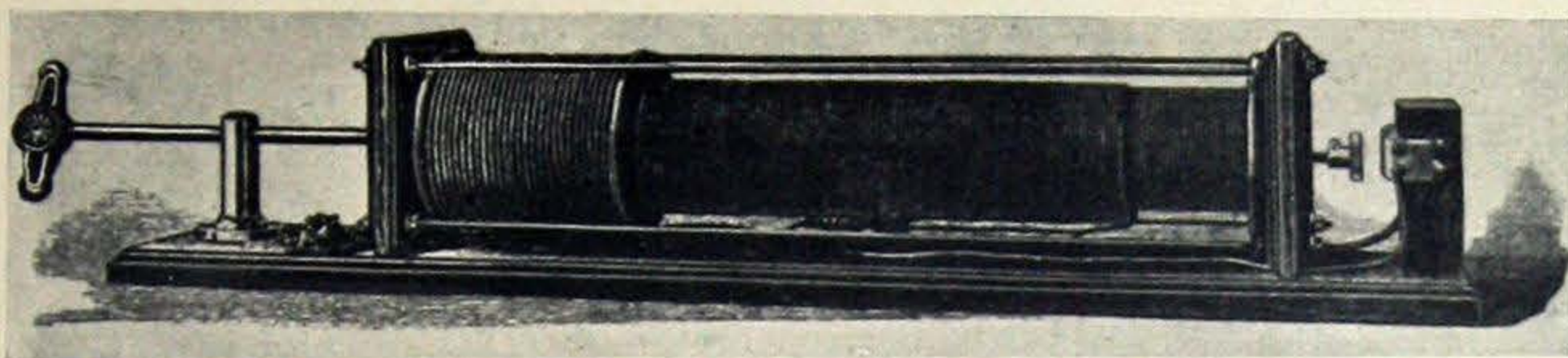

Figure 32—Reactance dimmer described by Dr. J. A. Fleming in the *Electrical World*, November 1890. The circuit diagram shows how, by moving the core in the coil more or less, voltage is produced across the terminal of the lamps. With the iron core completely within the section across the lamps, maximum voltage is produced, and with the core in the section in series with the lamps, maximum reactance and minimum voltage are produced—the effect of which is to cut down the current through the lamps.

transformer type as developed in the early days was the amount of space occupied. Ward Leonard Electric Company have solved the space problem in a.c. installations of very large size by combining the reactance and resistance methods of dimming in a new type of dimmer, in which the reactance in the main circuits is adjusted by means of standard Ward Leonard Vitrohm Dimmers, carrying less than 2 per cent. as much current as the lighting circuit controlled by the dimmer.

THEATRE LIGHTING CONTROL

Successful producers have always recognized the importance of suitable lighting facilities. Furthermore, they have realized the effects which they could obtain are limited only by the means of control at their disposal.

In 1905 Carl Lautenschlaeger formerly stage director at the Royal Bavarian Court Theatre in Munich, delivered an address before the Polytechnic Club in which he appraised the importance of control equipment. His opinion of theatre dimmers is set forth in the following quotation:

“The conductors converge in a so-called regulator (dimmer) the most

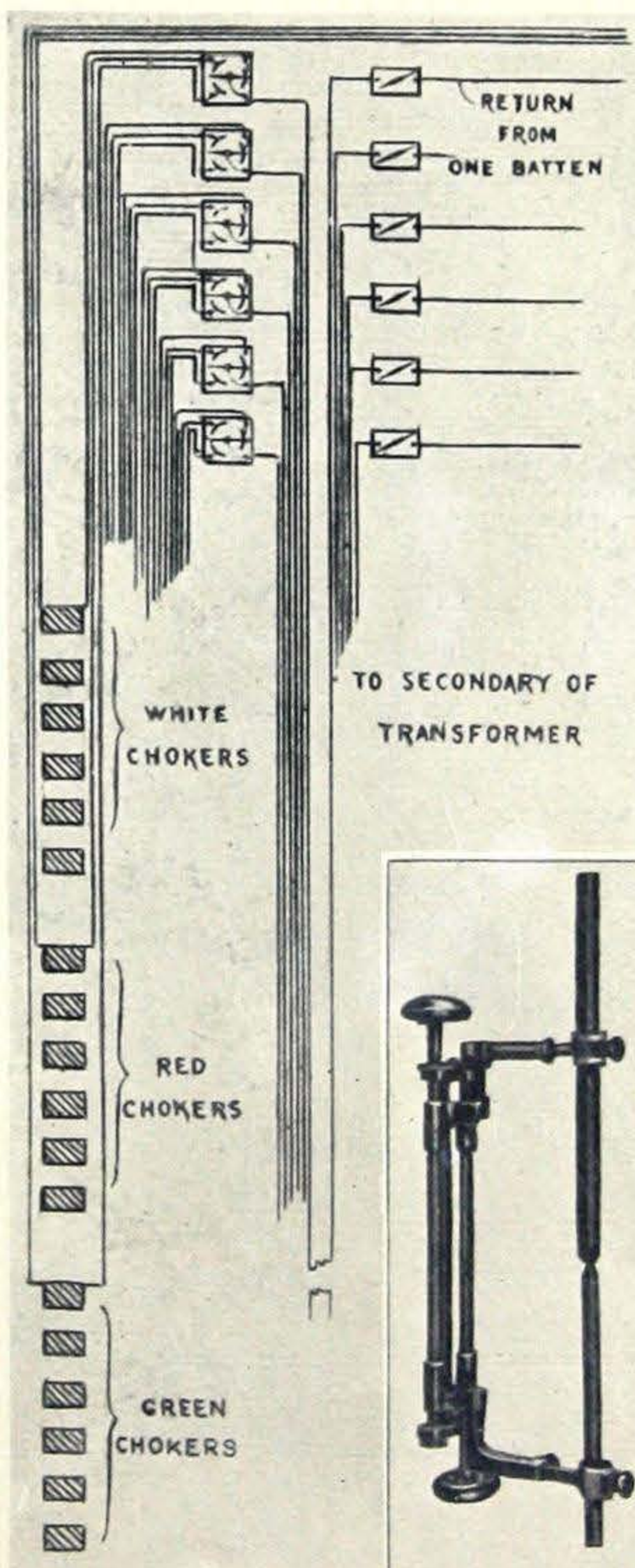

Figure 33—Circuit diagram of dimmer equipment in Earl's Court Theatre. The dimmers are called chokers. Arc lamp mechanism and rheostat used in spot light is shown in the insert.

important apparatus used in stage illumination. It includes all necessary appliances for graduating the intensity of the lights, both of the stage and in the auditorium. It permits the lighting and extinguishing of temporary lamps, and the sudden change of darkness to a blaze of light. As the switches for the production of color effects are also collected in the regulator, with a proper arrangement of apparatus, one man can produce every needed change of light and color, thus giving to the illumination even in difficult cases a perfect unity and harmony with the scene which contributes greatly to the success of the presentation."

The period of greatest development in theatre lighting control has been during the last twenty years, and today the leading producers give to lighting more attention than to any other single element which goes to make up the setting of a scene.

David Belasco, generally recognized as one of the most successful producers in this country, has contributed enormously to the development of effective application of lighting in the theatre. An idea of the importance which he attaches to this phase of his work may be gathered from a statement made by William Winter in his

"Life of David Belasco." He says:

"Readers will perhaps realize the importance Belasco attaches to the art of lighting as an adjunct to acting and the care he lavishes upon it when they are informed that the experimental workshop in his theatre is operated all the year round and that in many instances the expenses of his light rehearsals alone have exceeded the total of all other costs of production."

Ward Leonard dimmers have been used by Mr. Belasco ever since their first appearance on the market, and much of the development in the perfecting of this apparatus is built around experience gained under the direction of him and his electrician, Mr. Louis Hartmann.

PRESENT-DAY PRACTICES

Starting in 1846 in the Paris Opera, electricity gradually displaced all lighting for the theatre, and as the use of electricity spread, the perfection of its control developed.

Today, practically every lighting circuit in the theatre is controlled by dimmers.

In the past five years the amount of light used on the stage, and throughout the theatre, has more than doubled. Such a variation in what is now considered good practice makes the use of

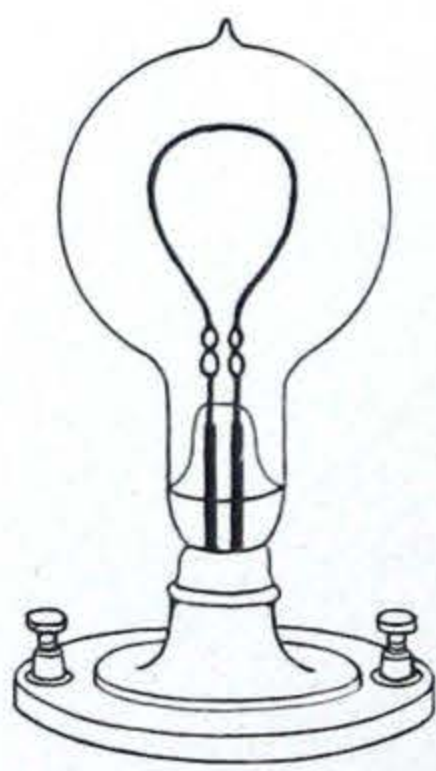

THE first incandescent electric lamp was invented by Edison in 1879 and was provided with a filament made by the carbonization of a bamboo fibre.

any present-day figures as merely comparative, and the figures given below are not intended to be used in actual application. The experience gained from numerous recent installations indicate that where an auditorium is decorated in silverleaf and light colors, 10 watts of lighting in each color should be provided for each seat. Where gold leaf and warm or heavy color decorations are adopted, 20 watts in each color should be provided for each seat to afford "reading" illumination. In urban motion

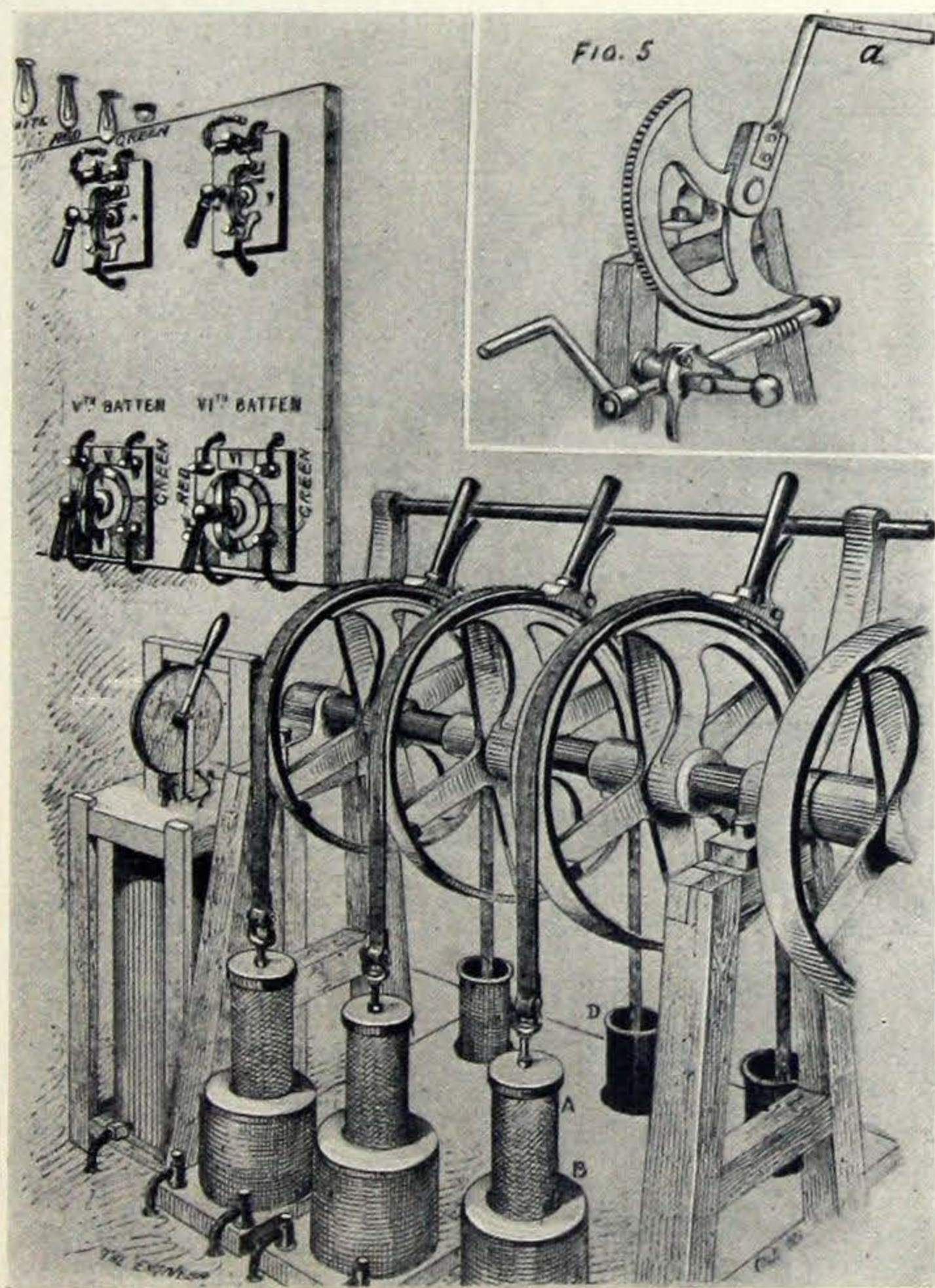

Figure 34—An early form of reactance dimmer used in Earl's Court Exhibition Theatre and described in *London Engineer*, November 1896. In this installation special attention was paid to the switching from one color to another. As one color decreased in brilliancy, the succeeding color was simultaneously increased in brilliancy. The arrangement here shown permits individual setting of the different circuits and also gives interlock and operation with a slow-motion worm and wheel, or by means of a master lever. Detail of master lever and slow-motion worm and wheel is shown in upper right-hand corner.

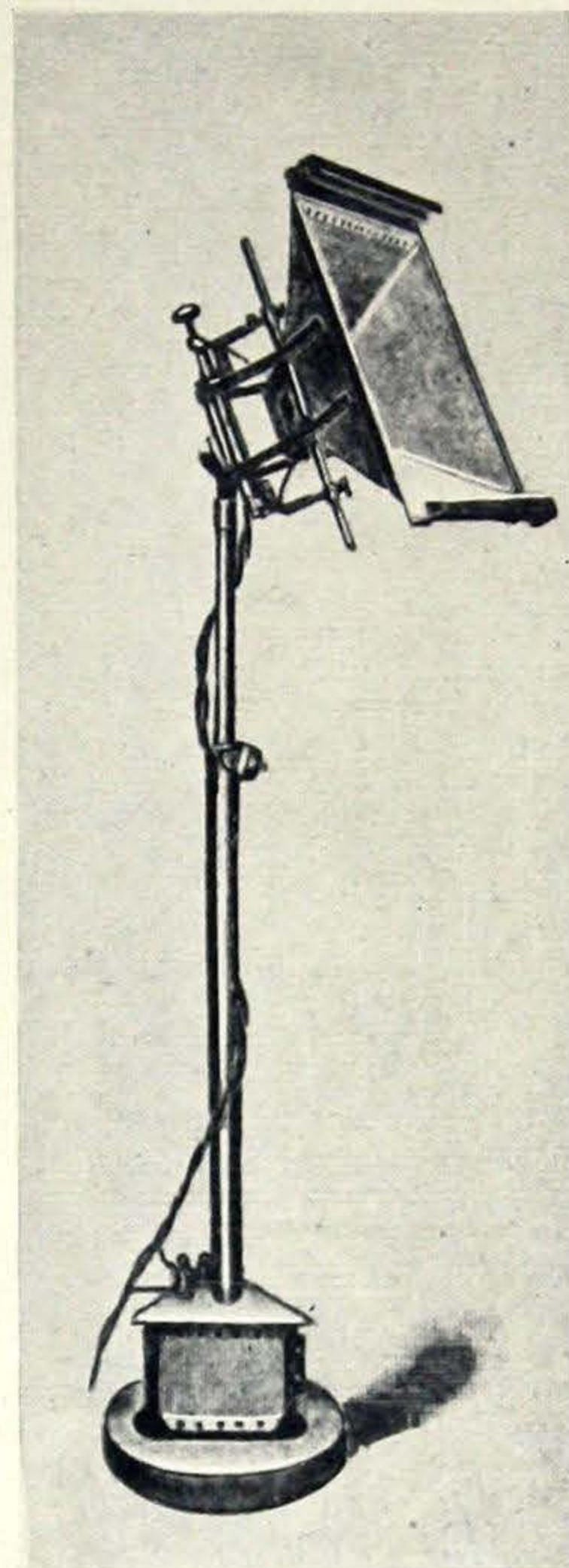

Figure 35—Spot light using an electric arc and providing for color screens, representing practice in 1898. From *The Electrical World*, May 1898.

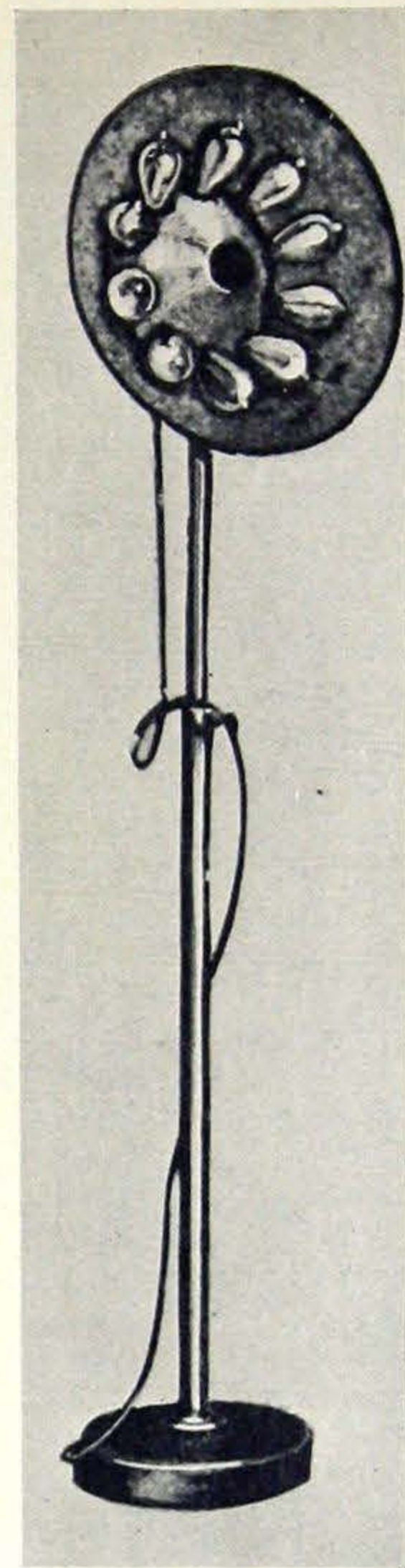

Figure 36—Bunch light made up of incandescent lamps in special bowl reflector as used in 1898.

picture theatres, where "reading" light is not required, satisfactory lighting has been effected with as little as 4 watts, each color, per seat.

In high-class theatres, using standard fixtures with matt white reflecting surfaces the practice is about as follows:

FOOTLIGHTS

In the footlights, two rows of lamps are used, one row of colored lamps back of a row of whites.

The footlights may be 4 to 8 feet less in length than the clear width of the proscenium arch. From 150 to 200

watts should be used in each color, per lineal foot of border.

STRIP LIGHT

On each side of the proscenium a "strip light" 12 to 18 feet high is recessed on the stage side of the arch. In this strip 100 to 150 watts of Type C lamps, each color, per lineal foot, are used.

BORDERS

Borders are generally from 4 to 10 feet less in length than the width of the proscenium arch. They are spaced 6 to 8 feet apart, and good practice is to have one work light at each end of each border. 100 to 125 watts of Type C lamps in each color are provided for each lineal foot of border.

Several floor pockets, each with three 50-ampere receptacles are conveniently spaced on each side of stage, also one at the rear, and one in the footlight trough.

For each receptacle there should be a 2,000-watt dimmer with sufficient ohms resistance to dim 1,000 watts.

The three receptacles in each pocket on a side are connected to different feeder switches—one feeder switch controlling the No. 1 receptacles of all pockets, a second switch controlling the No. 2 receptacles and a third feeder switch controlling the No. 3 receptacles.

One pocket with three 60-ampere receptacles is provided on each side of the stage

for connection to arc lamps.

A typical stage lighting plan is shown on page 58.

Due to the perfect control provided by suitable dimmers, the incandescent

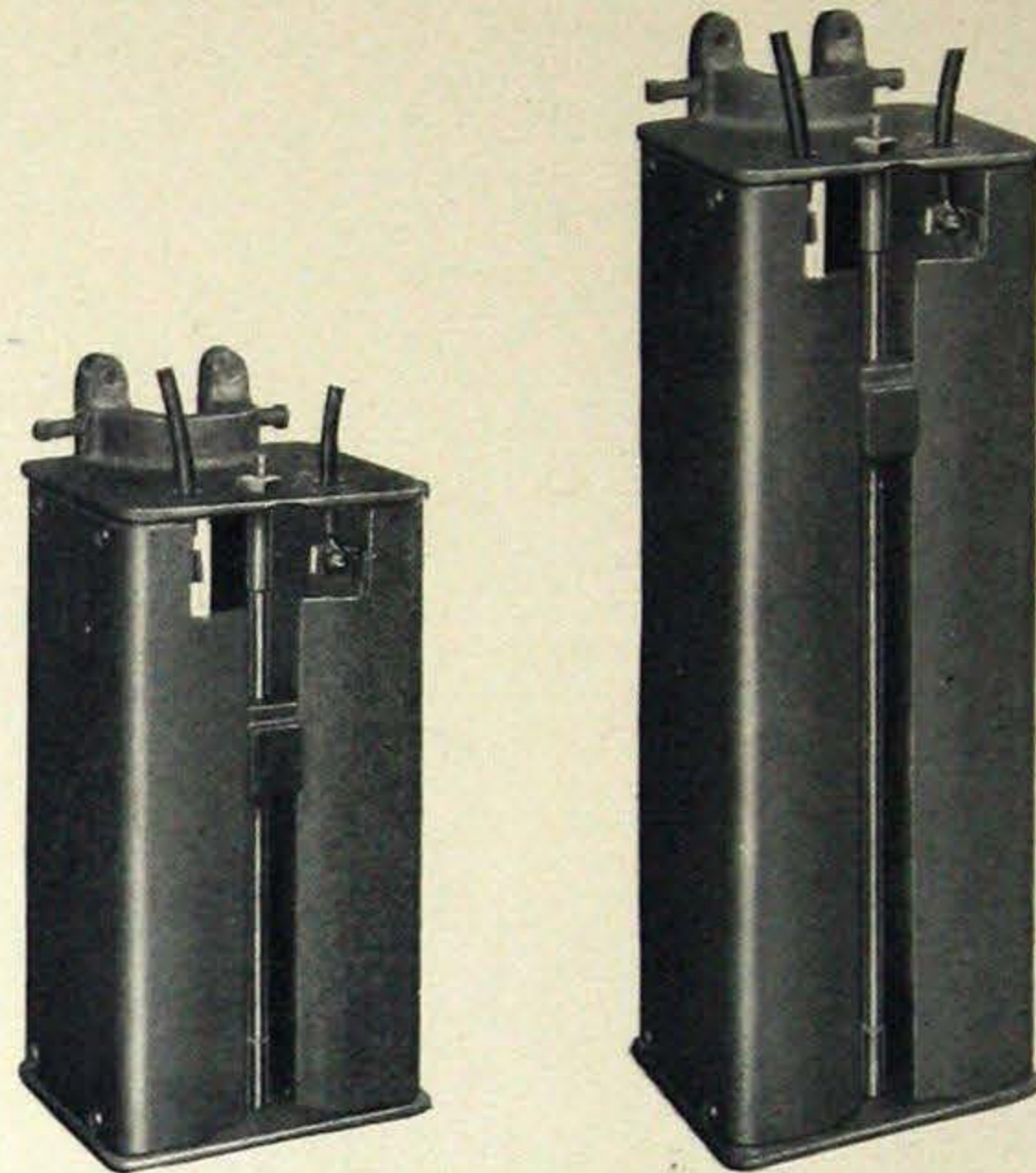
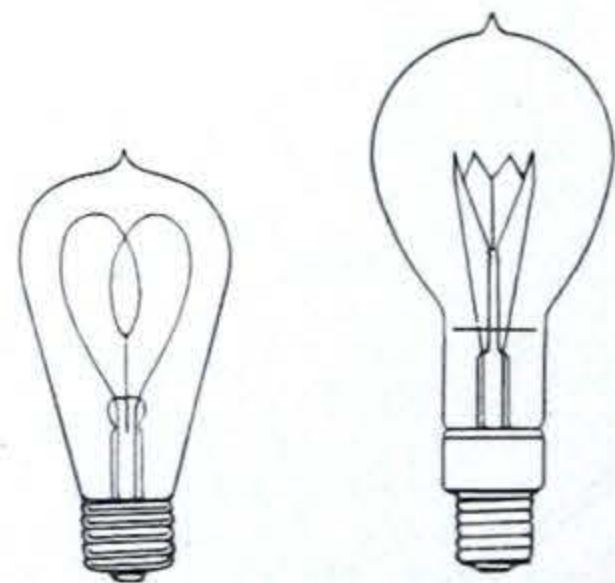

Figure 37—Ward Leonard Rheostats for spot-light control.

lamp is superseding the arc lamp for use as a spot light. Most spot lights are equipped with high-power nitrogen lamps controlled either from the dimmer board or by a

special dimmer on the stand. Not only has the effectiveness of the lamp been greatly increased, but the fire risk which was always an item has been practically eliminated.

Today, arc lights are used mostly in moving picture theatres for projection and spot light work, and in all cases they should be in enclosed fireproof booths.



EDISON'S incandescent lamp finally settled down to a carbon filament as the results of inventions of various engineers.

THE present-day representative of the incandescent lamp is the tungsten filament, or mazda lamp, and for the high-power units these lamps are usually filled with nitrogen.

WARD LEONARD DIMMERS

WARD LEONARD dimmers are made in a variety of sizes and types to meet all the requirements of theatres and other places of public assembly, such as halls, churches, and clubs. In fact, Ward Leonard dimmers are used in private residence installations on the one hand, and in the largest theatres on the other. They are adapted to the staging of theatrical productions in such a way, that the lighting program can be as definitely specified as the music and for the convenience of shows which travel, dimmer equipment designed for the production can be provided in portable form for shipment like all the rest of the properties of the play.

In general there are two fundamental types of Ward Leonard dimmers, namely, the type which utilizes resistance alone and the type which utilizes

reactance controlled by resistance.

The former is recommended for the smaller installations and the latter for the largest installations. The two overlap in the average size installation and choice can only be made when proper consideration is given to the space available and the value that is placed upon convenience of operation.

One fundamental principle which has always been followed in Ward Leonard practice, is that all dimmers shall be built for continuous operation at any point in their range of control. This is necessary for the safety of the dimmers themselves, and the installation as a whole. When dimmers are constructed with an intermittent duty rating, they are a liability, as it is impossible to adhere to an intermittent rating in conditions of actual operation.

WARD LEONARD VITROHM DIMMERS

VITROHM PLATES

The basis of all Ward Leonard dimmers is the Vitrohm plate—a type of rheostat developed and made commercially practical by H. Ward Leonard.

The Vitrohm plates are self-contained rheostats of extremely compact construction. The plate which furnishes the rigidity of the structure and provides for the mounting of the parts is a solid metal disk, on one side of which is mounted the resistor with its contact buttons. The resistor is applied to the plate by a patented Ward Leonard pro-

cess, then covered with a coating of special vitreous enamel and fired in a furnace at very high temperature. This

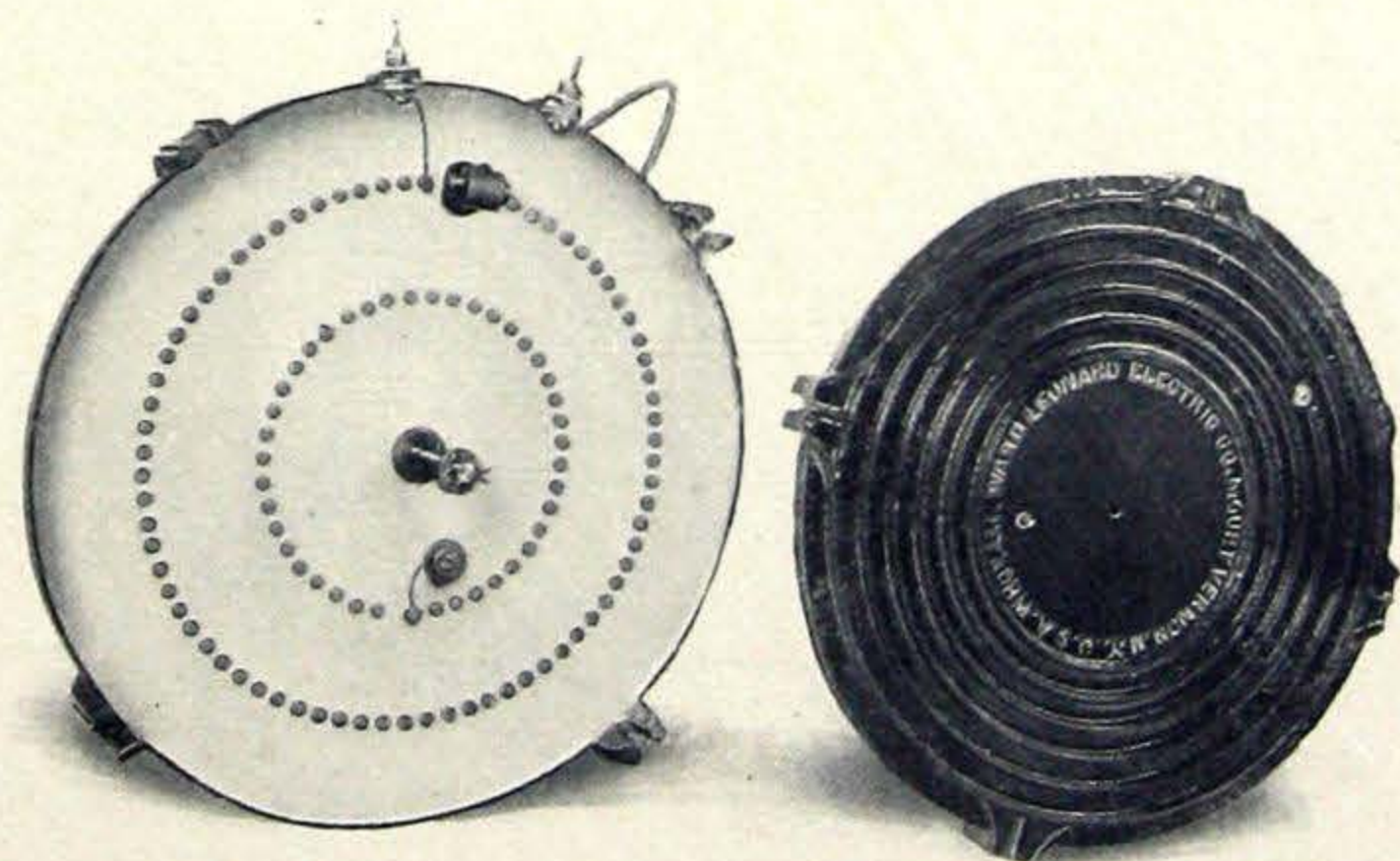

Figure 38—Ward Leonard Vitrohm Plates which form the resistor elements of Ward Leonard dimmers.

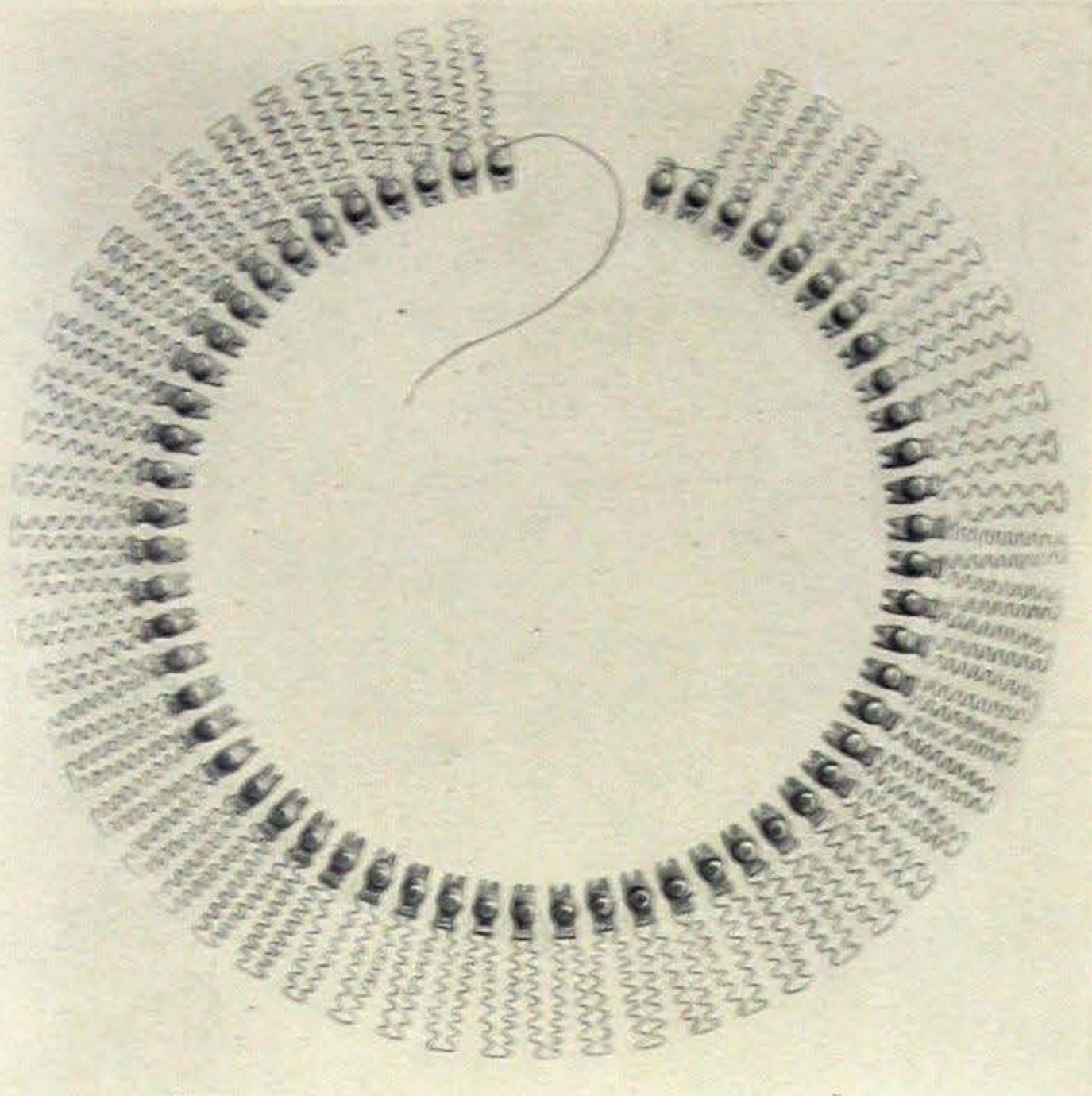

Figure 39 — Resistive conductor ready to be imbedded in the enamel of a Ward Leonard Vitrohm plate.

causes the enamel to penetrate the surface of the metal and virtually become a part of it. Upon this enamel surface the resistor proper is mounted, together with the stationary contacts which form the tap connections to the resistor. Enamel is next applied to the surface in sufficient quantity to imbed completely the resistive conductor, or resistance wire, and the base of the contact buttons, and the plates are again fired so as to fuse the entire mass into one integral structure.

The close relation of the resistor element to the metallic base promotes rapid dissipation of the heat generated to the whole plate and even to the supporting frame work.

Therefore the maximum operating temperature is much lower than in any other form of construction. At the same time, vitreous enamel will stand a higher temperature than any other material used for embedding and supporting resistor elements.

The temperature at which the firing takes place is many hundred degrees higher than will ever be encountered in practical use—an actual demonstration of the indestructible nature of Vitrohm construction.

The vitreous enamel which supports, insulates and protects the resistive conductor is dense and impervious to moisture. Therefore, it affords protection against mechanical, electrical and chemical depreciation, and permanently retains the physical and electrical properties of the resistive conductor which is the heart of any dimmer.

CONTACTS

One of the important improvements made by H. Ward Leonard when the Vitrohm plate was invented was the elimination of the leads which formerly were used to connect points along the resistance wire to contact buttons on the dial switch. In the Vitrohm plate the contact buttons are attached direct-

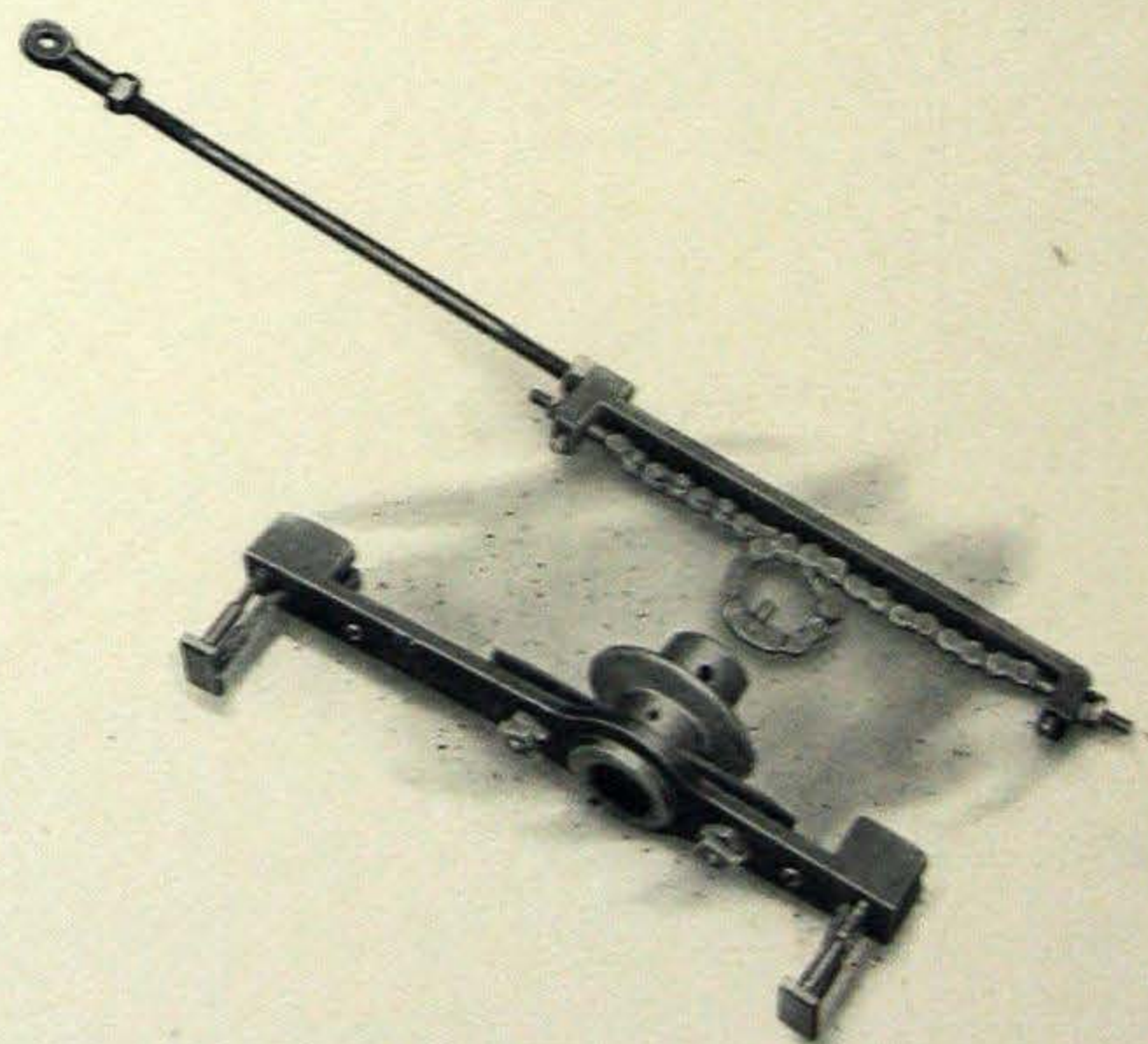

Figure 40—Contact arm and contact-arm drive of Ward Leonard Vitrohm dimmer plate. The contact shoes are provided with long plungers which permit them to ride easily over the contacts and maintain a proper contact pressure under all conditions. The drive gives a positive, though flexible connection that operates with little friction.

ly to the resistive conductor by a mechanical joint between the two made under high pressure when the metals are bright and clean.

The advantages of this joint are many. It contains no solder or tin, the resistive conductor does not have to be cut to make the joint with the contact buttons and the union is therefore permanent and not dependent on clamps, bolts or screws. The joint undergoes the firing process and therefore is not affected by any temperature it may later encounter. In short, it is an important element which helps to make Ward Leonard plate dimmers fire-proof and permanent.

The stationary contact buttons are made of heavy stamped brass so formed that the joint with the resistive conductor and the supporting base is completely imbedded in the vitreous enamel and solidly attached to the plate. The contact surfaces over which the movable contact (or skate shoe) travels project well beyond the surface of the plate, thus preventing the accumulation of dust and dirt on or between the contacts, which might cause short-circuit or poor contact.

CONTACT ARM

The adjustment of the resistance of a Vitrohm plate is accomplished by means of a pivoted arm called the contact arm, which bridges two concentric groups of contacts on the plate and thus permits the variation in small steps of the amount of resistive conductor included in the circuit. This arm is rotatively mounted on a shaft at the center of the

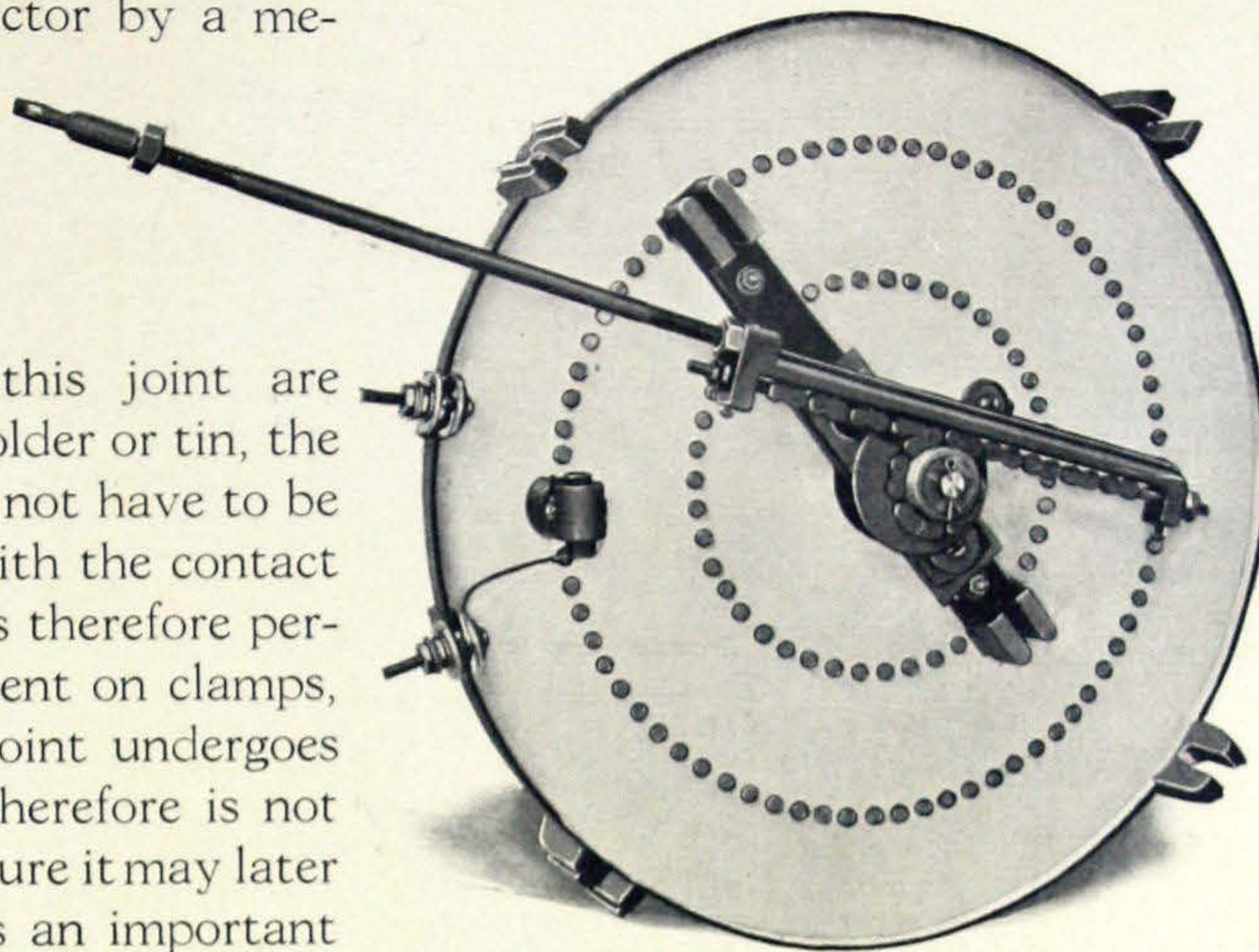

Figure 41—Contact arm and contact-arm drive assembled on Vitrohm dimmer plate.

plate and is provided with self-adjusting contact shoes, or skates, which automatically take care of any variation in the height of the contacts.

These shoes are made of self-lubricating metal and are each provided with two plungers that extend into corresponding holes in the contact arm. Therefore, the shoes are pressed with definite force against the contact buttons by means of coil springs operating on the pins. The electrical circuit is carried from the shoe to the arm by means of flexible copper

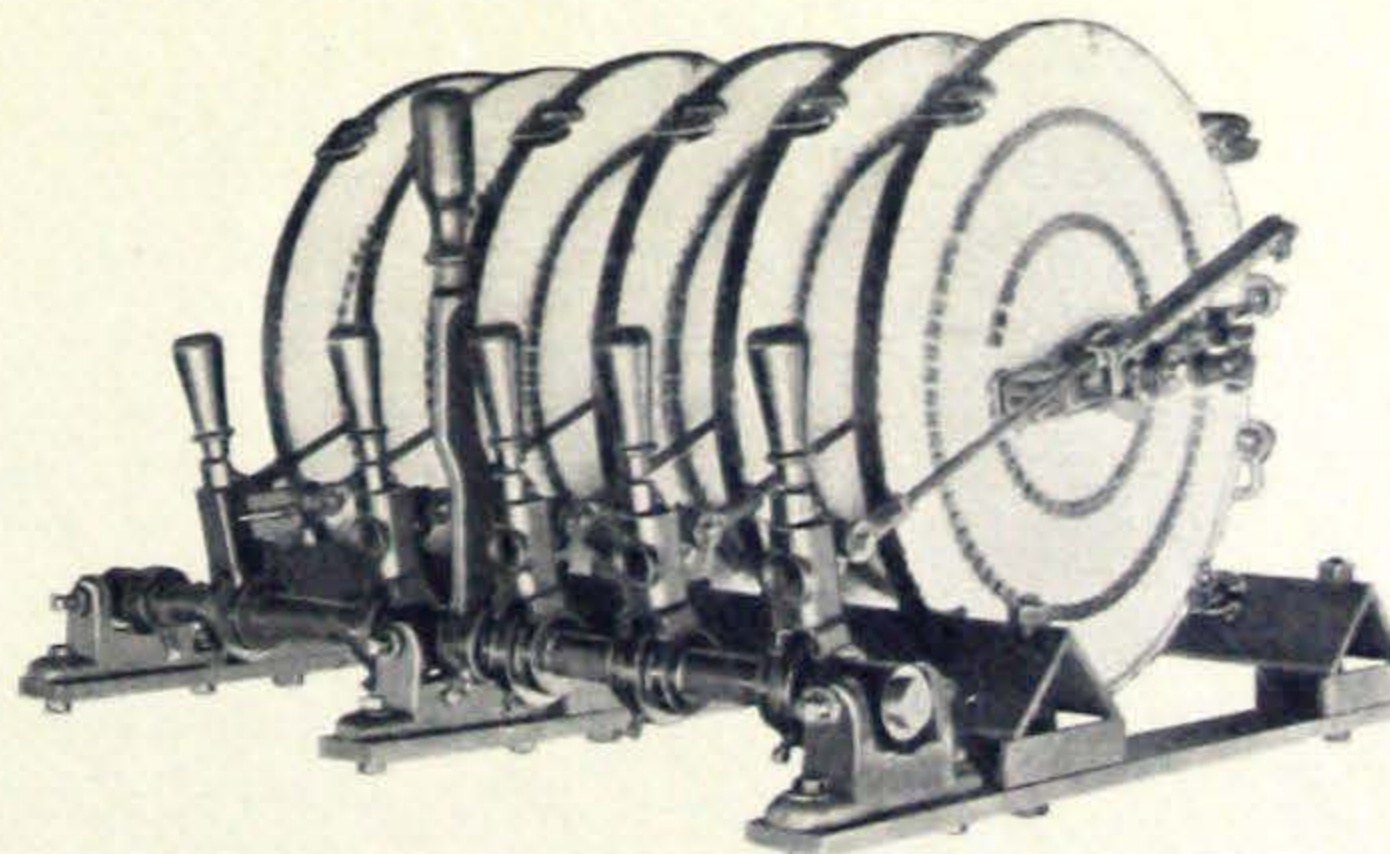

Figure 42—Small bank of Ward Leonard Vitrohm dimmers equipped with independent handles and master handle.

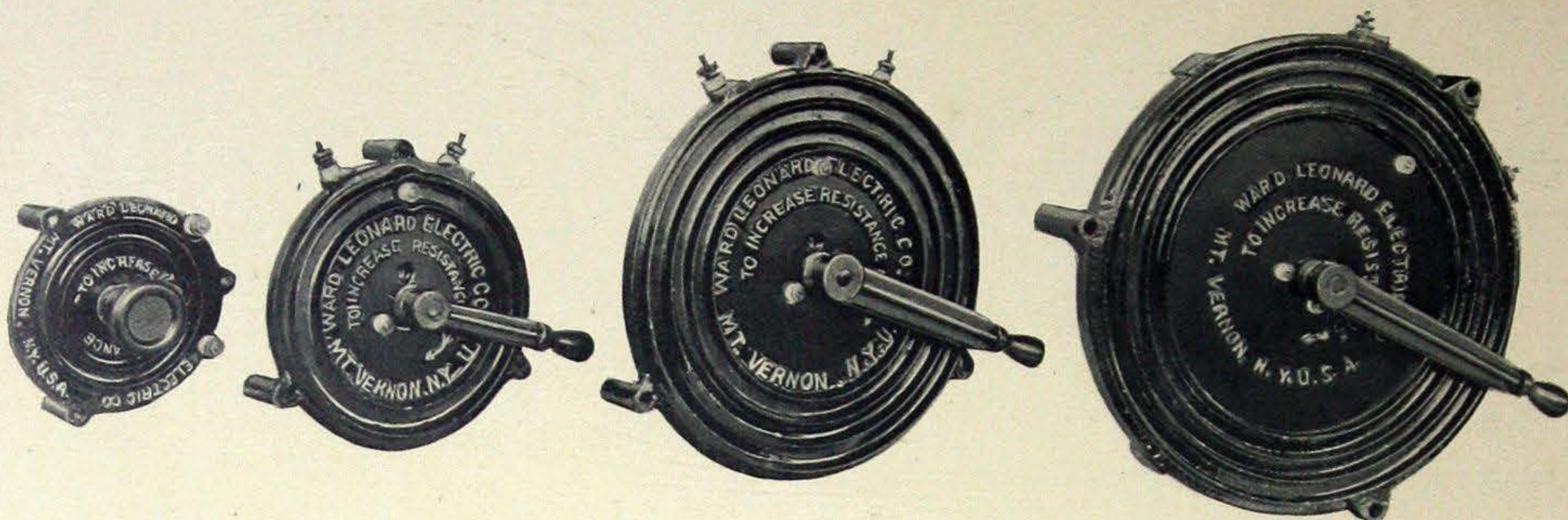

Figure 43—Variety of sizes of Ward Leonard dimmer rheostats for single-plate installations.

leads fastened permanently into the rear face of the shoe. Figure 40 shows an arm of this type with the shoe pins entirely removed from the guiding holes in the arm.

CONTACT-ARM DRIVE

In the earliest dimmers the handle manipulated by the electrician swept through the same arc as was occupied by the contacts over which the contact arm played. In the Ward Leonard Vitrohm Plate Dimmer the contact arm is rotated through a flexible drive which multiplies the motion of the hand several times.

The device employed to translate the straight line motion to a rotary motion is peculiarly effective. It consists of a cast iron bow equipped with a brass link chain, which is wrapped once around the hub of the contact arm and positively engages it by means of a single heavy steel pin. The two ends of the chain are attached to the bow by means of wing nuts at each end which provide for accurate adjustment of the tension. Moving the bow backward and forward causes the contact arm to rotate as the chain winds on from one side and off from the other. This mechanism requires no lubrication,

and unlike the rack and pinion which is the usual method employed for translating straight line motion to circular motion, is not sensitive to wear, or to dirt, and consequently requires much less effort to operate.

DIMMER BANKS

The dimmer as a complete installation consists of an assembly of Vitrohm plates. Such an assembly may be made in a great variety of ways depending upon local conditions as to space and lighting requirements. In general, the plates are assembled in one or more rows in a structural steel frame, in front of which the handles are rotatively mounted on one or more shafts. These levers are connected to the bows by which the contact arms are rotated, so that by moving the handle through a comparatively small arc the corresponding contact arm on the Vitrohm plate can be rotated through its full range.

The independent handles are arranged with a latch device which permits them to be locked to the shaft on which they are mounted, or to rotate freely about it. By providing the shaft

with a lever which is called a master handle, it is possible to manipulate at one time as many units as may be locked to the shaft, and at the same time any individual unit or group of units may be released from the shaft and operated independently. Again, by shifting the position of the master handle, it is possible to increase the resistance of one group of plates that is locked to the shaft and at the same time with the same motion decrease resistance in another group. In this way one group of lamps can be increased in brilliancy, while another group is decreased. This result is called "cross interlocking control."

Where several rows of dimmer plates

are required, each row is equipped with its line of handles mounted on a shaft, and the various rows are interlocked by means of master handles which permit the operation of all or any number of parallel shafts with their connected independent handles by a single master handle. Furthermore, in many cases the whole dimmer equipment is arranged so that it can be operated from slow motion worm and gear connected to a hand wheel at the front of the dimmer, in which event all plates which are locked to their respective shafts and all shafts which are locked to one another can be operated from the one point in a slow smooth fashion.



Figure 44—The Shubert-Jefferson, leading dramatic theatre in St. Louis, is equipped with Ward Leonard Vitrohm dimmers.

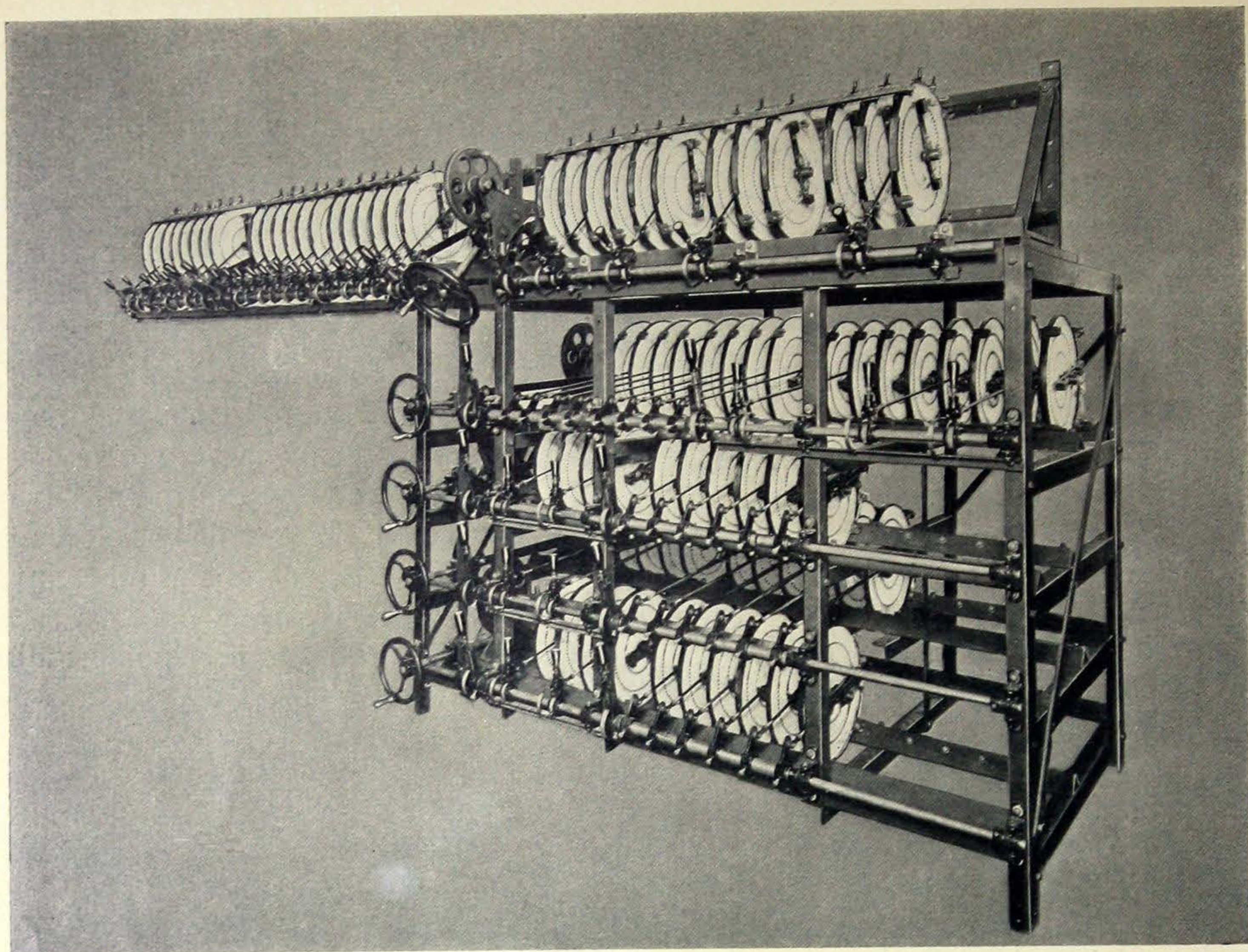

Figure 45—Floor Type Ward Leonard Dimmer Bank installed in Loew's Theatre, Los Angeles. Space below the overhanging row of plates at left allows for the installation of switchboard.

ADVANTAGES

The unique design and construction of Ward Leonard Vitrohm Dimmers provide many advantages from both installation and operating standpoints. Some important ones are:

1. All Vitrohm Dimmers are *continuous duty dimmers*.
2. Minimum space required for a given service.
3. Minimum weight for a given service.
4. Reliability of operation.
5. Ease of manipulation.
6. Durability of construction.
7. Simplicity of upkeep.
8. Absence of fire risks.

SPACE

Vitrohm plate construction, permitting free heat radiation, together with the simple mechanism used to rotate the contact arm, are responsible for the compactness of construction in Ward Leonard dimmers. Each unit when assembled into a bank occupies only four inches of space in the axial direction.

WEIGHT

The light weight of Ward Leonard Vitrohm Dimmers follows from the high efficiency attained in the radiation of heat from Vitrohm plates. Efficient radiation in electrical apparatus indicates economical use of material.

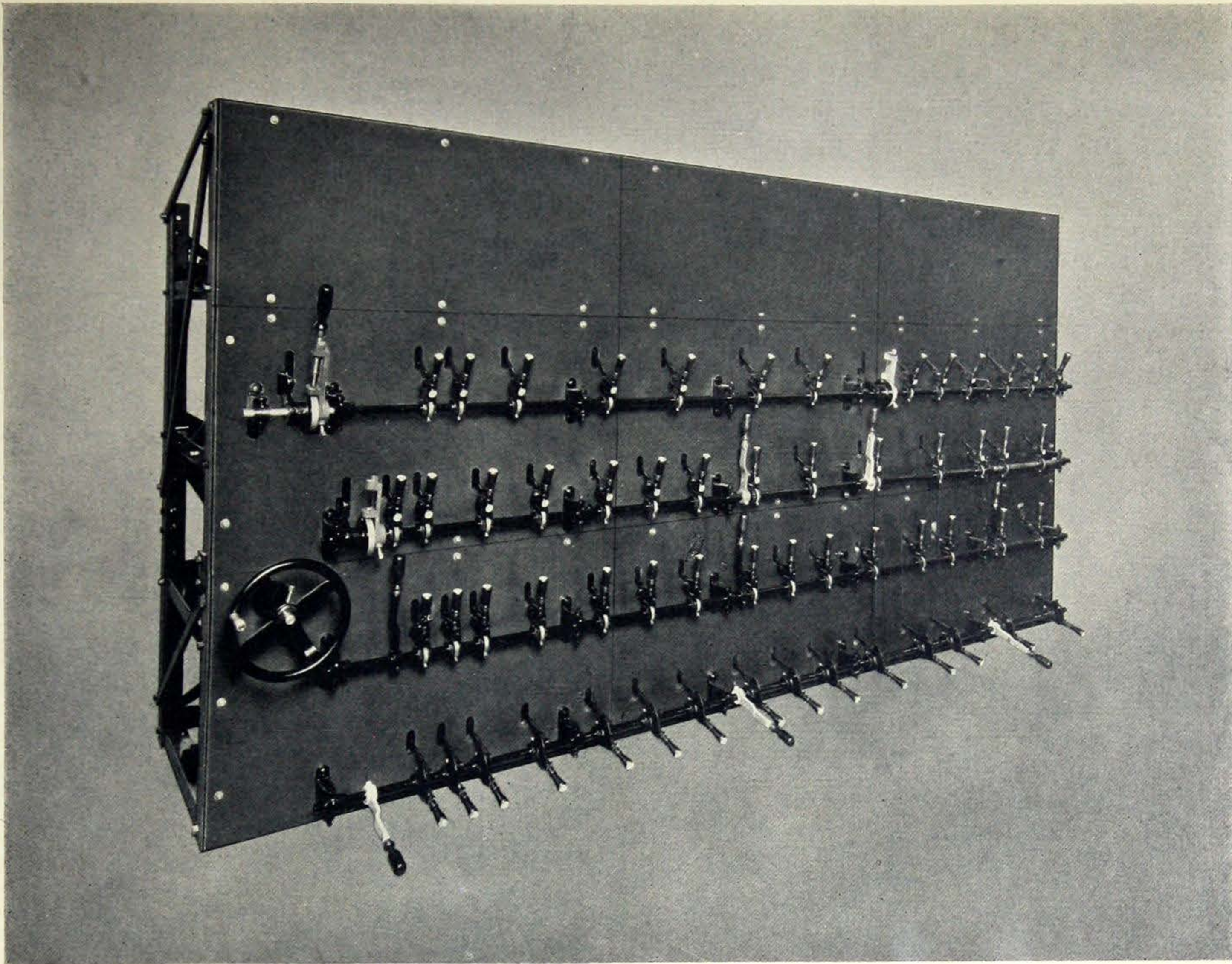

Figure 46—Floor Type Ward Leonard Dimmer Bank installed in Raymond Theatre, Pasadena, Calif.

CAPACITY

All Ward Leonard Vitrohm Dimmers will *carry their full rated load continuously* at any point in their range without undue rise in temperature. This extraordinary capacity is simply another advantage of the Vitrohm plate type of construction which insures the rapid dissipation of heat so necessary in a rheostat for this service.

RELIABILITY

The resistors in Ward Leonard dimmers are made of metals practically unaffected by temperature changes, and are absolutely protected by vitreous

enamel from any kind of deterioration. Therefore, the resistance values will remain constant under all conditions of service. Then, too, the flexible-link drive by which the rheostats are manipulated gives a positive connection which will hold a given adjustment indefinitely.

MANIPULATION

The easy riding self-adjusting contact shoes, as well as the low friction of the flexible-link drive make the manipulation of the rheostats extremely easy, so that an operator can control with one hand a dimmer of twenty and more plates.

DURABILITY

There are no fragile elements in a Ward Leonard dimmer. The Vitrohm plates are made of metal sufficiently strong and rigid to stand shipment anywhere and to protect the resistor from mechanical strain or damage. The contact buttons, the arm and the flexible-link drive for rotating the arm, including the operating levers and other accessories, are all designed along engineering lines and will never wear out under ordinary usage.

UPKEEP

By using the flexible-link drive no lubrication is necessary at points between the plates. All bearings which

might require oiling are of the simplest construction and mounted in accessible position in front of the bank. The contact shoe, which ordinarily is subject to considerable wear in rheostats of this kind, in Vitrohm dimmers requires no attention or adjustment. This type of shoe has been standard in Ward Leonard rheostats for twenty years and installations made in the beginning of this period are still in operation without renewals.

ABSENCE OF FIRE RISK

There being no material in the active parts of the dimmer which has not undergone the firing temperature of the enamel, there is no danger of starting a fire in any part of this equipment.

THEATRE DIMMER NOMENCLATURE
MECHANISM

Dimmer—A controller for adjusting the intensity of light by varying the current in the lamp circuit.

Dimmer Plate—A rheostat, including base, resistor, stationary contacts, terminals and contact arm.

Contact Arm—A movable arm which makes connection with stationary contacts and the position of which determines the resistance in the circuit.

Dimmer Handle—A lever which controls the movement of the contact arm.

Contact Arm Drive—Mechanism operated by the dimmer handle to move the contact arm.

Dimmer Bank—A number of dimmers mounted as one unit.

Interlocking Dimmer Bank—One in which the dimmer handles are mounted on a shaft to which they may be latched or unlatched.

Interlocking Dimmer Handle—One which is provided with latching mechanism.

Master Handle—One which rotates a shaft to which interlocking dimmer handles may be latched.

Interlocking Master Handle—One which is provided with latching mechanism.

Grand Master Handle—One which controls interlocking master handles.

Slow Motion Wheel—A hand wheel operating through gears to control interlocking master handles.

Cross Control Mechanism is one by which one or more interlocking master handles may be simultaneously moved in the same or opposite direction to others, by the movement of one handle or wheel.

Pre-set Interlocking Dimmer Handle is one which may be automatically latched or unlatched from connection with others, at a predetermined position.

CONTROL

Interlocking Control—A control which permits the grouping of dimmers so that the movement of a master handle or master wheel will control one or more dimmers as a unit, without interfering with the independent control of any single dimmer.

Cross Interlocking Control—An interlocking control which, by the movement of one handle or wheel, permits the dimming of any group of lamps while any other is simultaneously brightened.



Belasco
Theatre,
New York

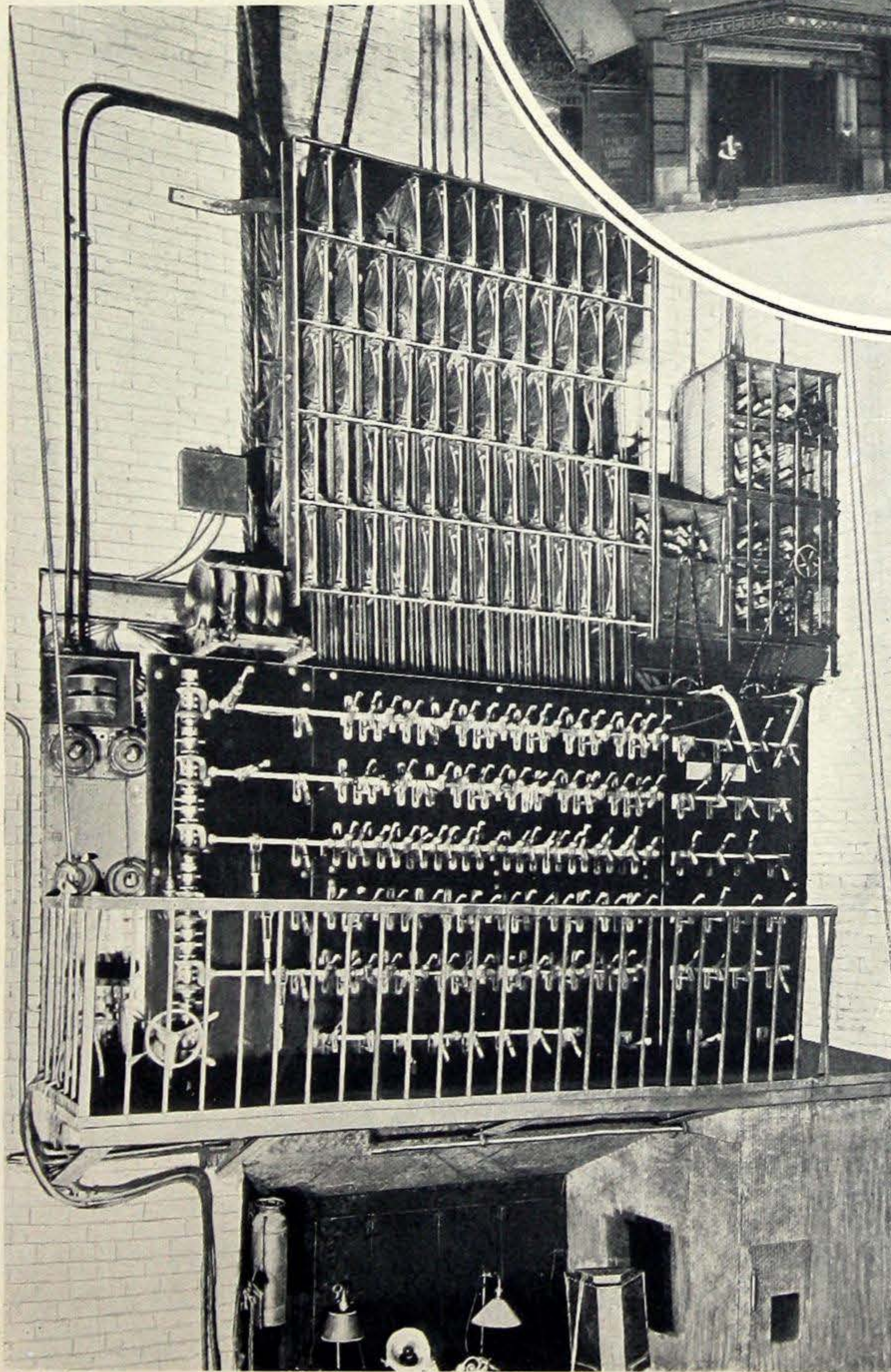

Ward Leonard Dimmer Equipment in the Belasco Theatre. Installed years ago to control the 3,000 amperes lighting load, here installed, and still able to give service which is highly satisfactory to Mr. Hartmann, the Electrician, and the exacting Mr. Belasco.

WARD LEONARD DIMMER INSTALLATIONS

Perhaps the most effective way of presenting Ward Leonard dimmers is to illustrate and describe a series of typical installations, because a picture of an actual installation often gives a better idea of the possibilities in the application of the equipment, than a word description of the elements which are combined to make a complete installation.

The majority of dimmer installations may be divided into three classes as far as mounting is concerned:

1. Floor mounting.
2. Top-of-board mounting.
3. Portable mounting.

As far as control is concerned, they may

be divided into the following three classes:

1. Manual lever control.
2. Manual slow-motion control.
3. Remote automatic control.

These various types of equipment are illustrated throughout the book by reproductions from photographs of dimmer banks and installations. Each is discussed briefly in the captions. If the data given is insufficient, additional information will be gladly furnished upon application.

The purpose of these pictures is to show what has been done with Ward Leonard dimmers and in this way it is hoped to assist architects, contractors and others in obtaining the best results.

LAYING OUT DIMMER BANKS

Too much cannot be said in favor of giving early consideration to dimmer equipment in planning a theatre or other structure where dimmer equipment is to be used. Too often this important element of the plant is ignored until the structure is built and all the principal elements which it houses have been determined and provided. The dimmer equipment under such conditions must be put wherever space can be found, irrespective of convenience. In making plans which allow for dimmer equipment, the first step is to determine the capacity of the dimmer required. The second step is to decide upon the location which will be best suited when considered from all

points. Of the utmost importance is the location of the dimmer equipment and switchboard close to the proscenium arch on the "prompt" side of the stage. In too many instances the error is made of allowing space only sufficient for the switchboard, and the dimmers have to be mounted over the board with the levers out of reach of the operator. The third point is the determination of the amount of space required to provide the necessary dimming facilities and proper ventilation.

DIMMER CAPACITY

In selecting the dimmer corresponding to the capacity of the circuits to be controlled, reference should be made to Table I where the lamp load in watts is

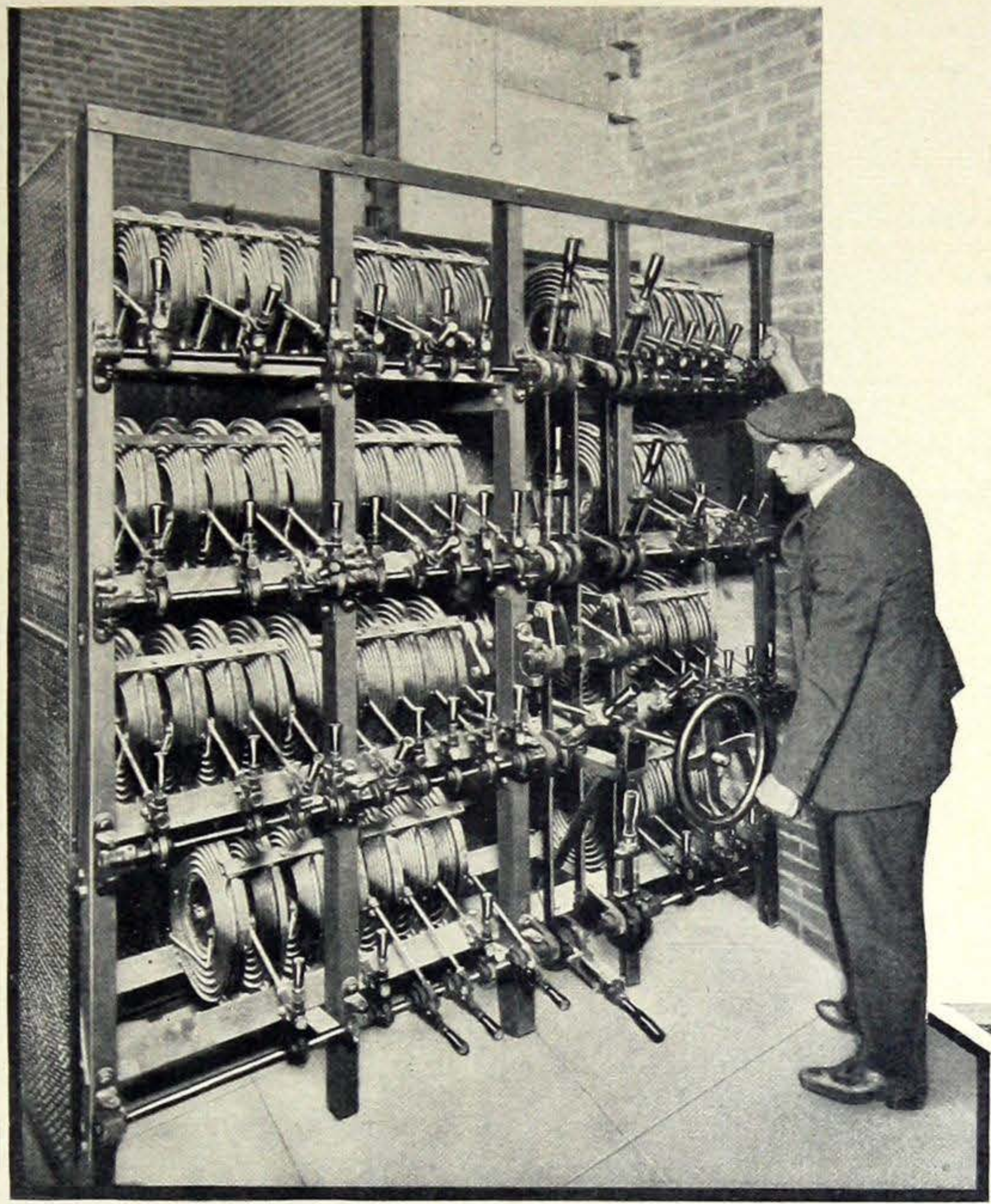

Ward Leonard Dimmer Bank installed in the State Theatre in Jersey City, N. J. This dimmer regulates the colored lights in the elaborate chandelier above the auditorium, as well as the stage lighting.

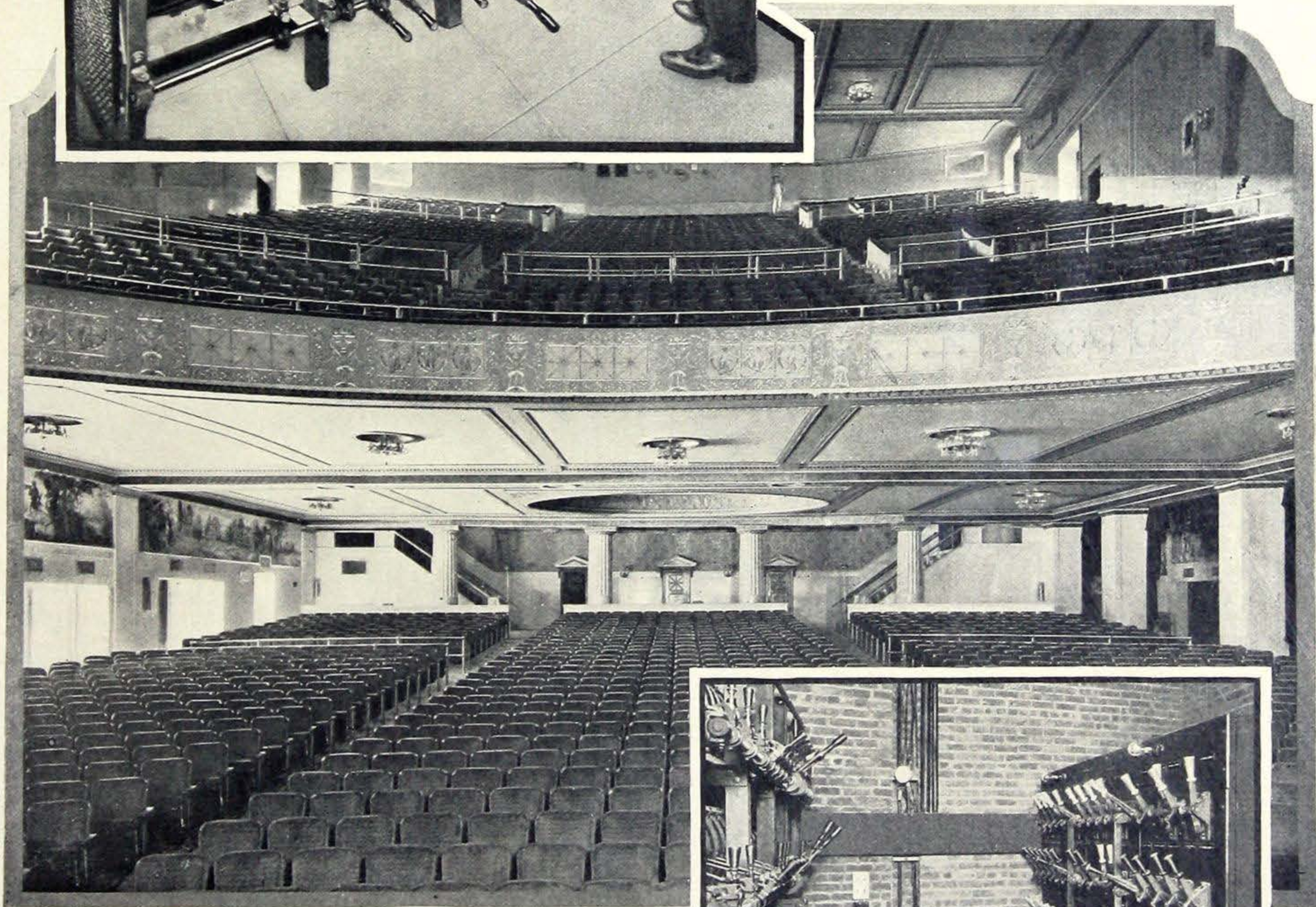

Interior of the State Theatre. To the right is shown the relative location of dimmers and switchboard.

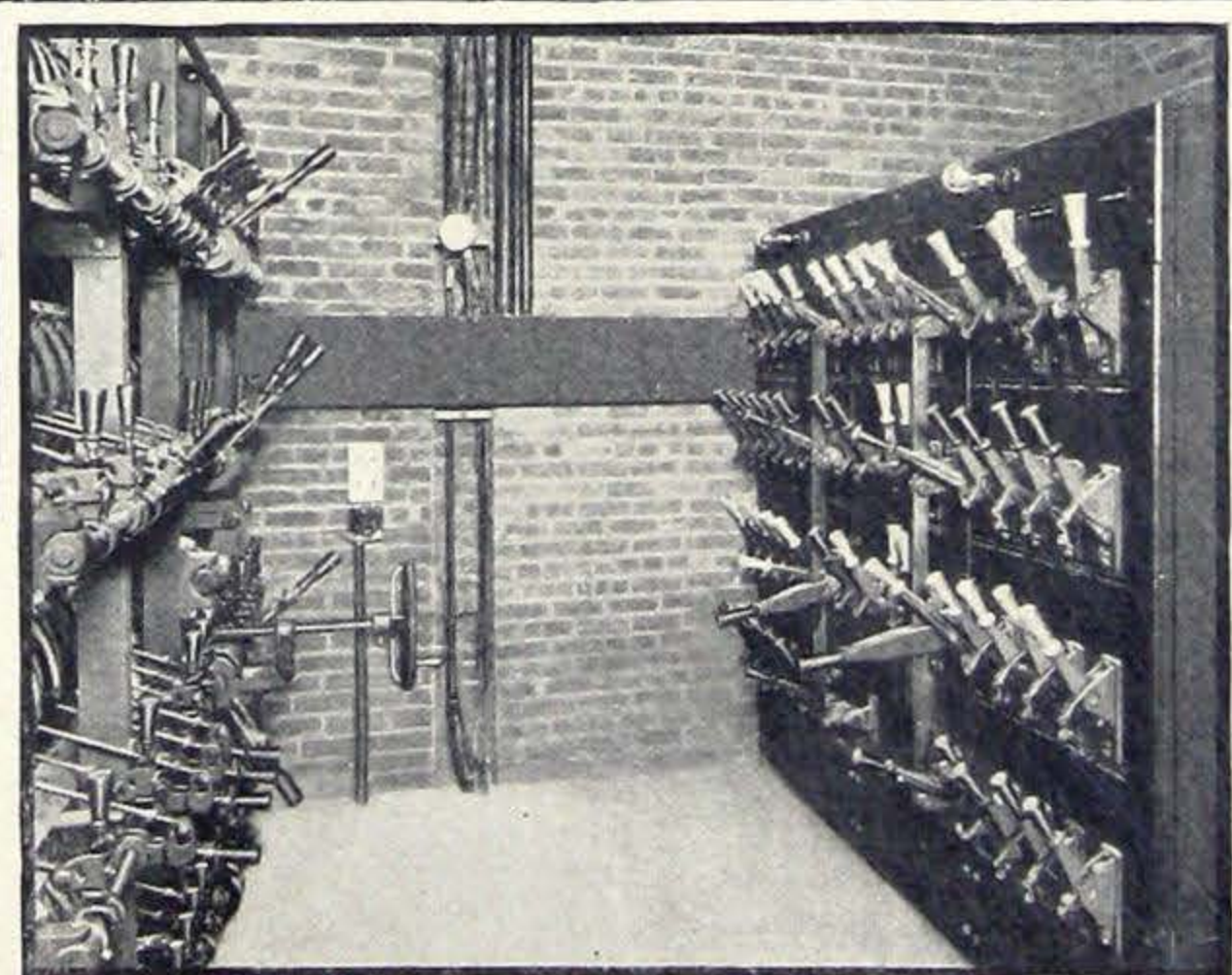

given for dimmers of different capacities made up in five standard assemblies.

SPACE REQUIREMENTS

The approximate space requirements of a dimmer bank depends not only upon the size of the dimmer but also the type of assembly. The number of plates in a dimmer is determined from Table I and dimension factors, which when multiplied by the number of plates will give the length of the dimmer, are listed in Table II (opposite page) together with the overall end dimensions of each layout.

The values obtained in the foregoing method of calculating space requirements are based on the average width ordinarily occupied by each individual plate in a bank of dimmers of the type in question. Naturally, plates may be assembled in different arrangements to meet special requirements and when so assembled the over-all dimensions will vary accordingly. It is always best to consult the manufacturer and obtain certified dimensional drawings before final layouts are made.

VENTILATION

The rating of a dimmer is based on its ability to dissipate heat, and if it is to be operated successfully at full capacity, there must be no restriction of the flow of air between the plates from the bottom to the top. Especially should the dimmers be open at the top so that heated air can move rapidly out of the way and let cold air take its place. Dimmers should not be installed underneath an obstruction.

REMOTE CONTROL

Sometimes installations work out in such a way that sufficient space for

TABLE I
TYPE RD INTERLOCKING DIMMERS
for 115 volt 2-wire circuits

Lamp Load in Watts	Style	No. of Plates	Catalog Number
500	A	1	RD 15
750	A	1	RD 17
1000	A	1	RD 110
1320	A	1	RD 112
1500	A	1	RD 115
1700	A	1	RD 117
2000	A	1	RD 120
2400	A	1	RD 125
2700	A	1	RD 125
3000	A	1	RD 130
3300	A	1	RD 130
3600	B	2	RD 134
4200	B	2	RD 138
4800	B	2	RD 144
5400	B	2	RD 150
6000	B	2	RD 160
6600	C	3	RD 166
7200	C	3	RD 166
8100	C	3	RD 174
9000	C	3	RD 190
10200	D	4	RD 1000
12000	D	4	RD 1200
15000	E	5	RD 1500

housing the dimmer is not available at the point where the control of the lighting should be located. In such instances remote control is employed.

In laying out remote-control installations the engineering department should be consulted at the very beginning, as the variety of factors involved in design is too great to be covered by general rules.

ARCHITECTS' TYPICAL SPECIFICATIONS

To assist those who would specify standard Vitrohm dimmer equipment, outline specifications have been prepared to cover the principal points that play an important part in the success of a dimmer installation. (See page 44.)

DIAGRAMS OF AVERAGE SPACE REQUIREMENTS

TABLE II

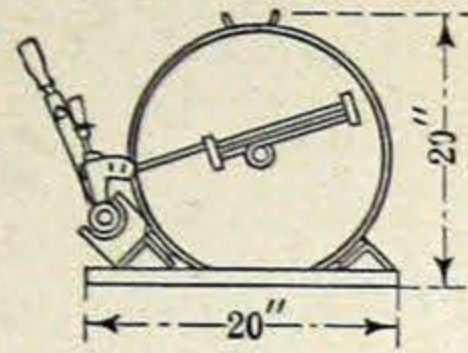

Diagram 1
INTERLOCKING CONTROL
IN SINGLE ROW

To obtain an approximate length of a bank of this type multiply the number of plates by 4.5 inches.

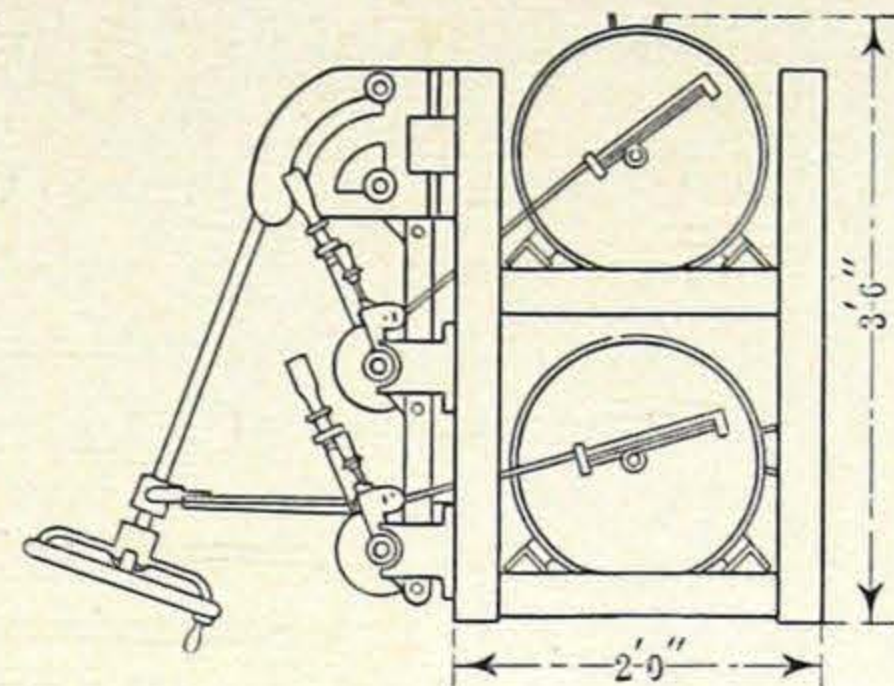

DIAGRAM 13
CONTROL WITH CROSS INTER-
LOCKING SLOW MOTION
WHEEL TWO ROWS HIGH

To obtain an approximate length of a bank of this type multiply the number of plates in the white stage and white house sections by 4.4 inches.

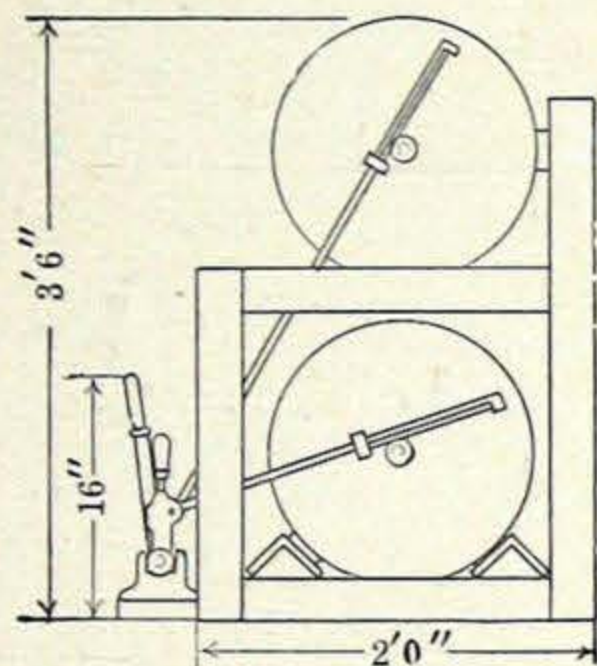

Diagram 7
INTERLOCKING CONTROL
TWO ROWS HIGH

To obtain an approximate length of a bank of this type multiply the total number of plates by 3.2 inches.

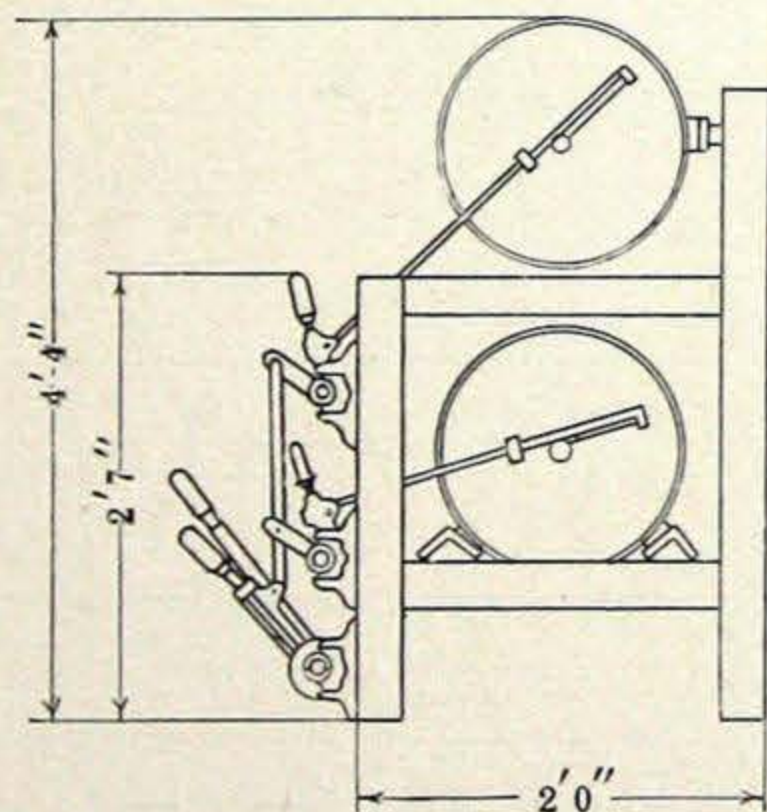

Diagram 11
INTERLOCKING CONTROL
WITH GRAND MASTER
HANDLE TWO ROWS HIGH

To obtain an approximate length for a bank of this type multiply the number of plates in the white stage and white house sections by 3 inches.

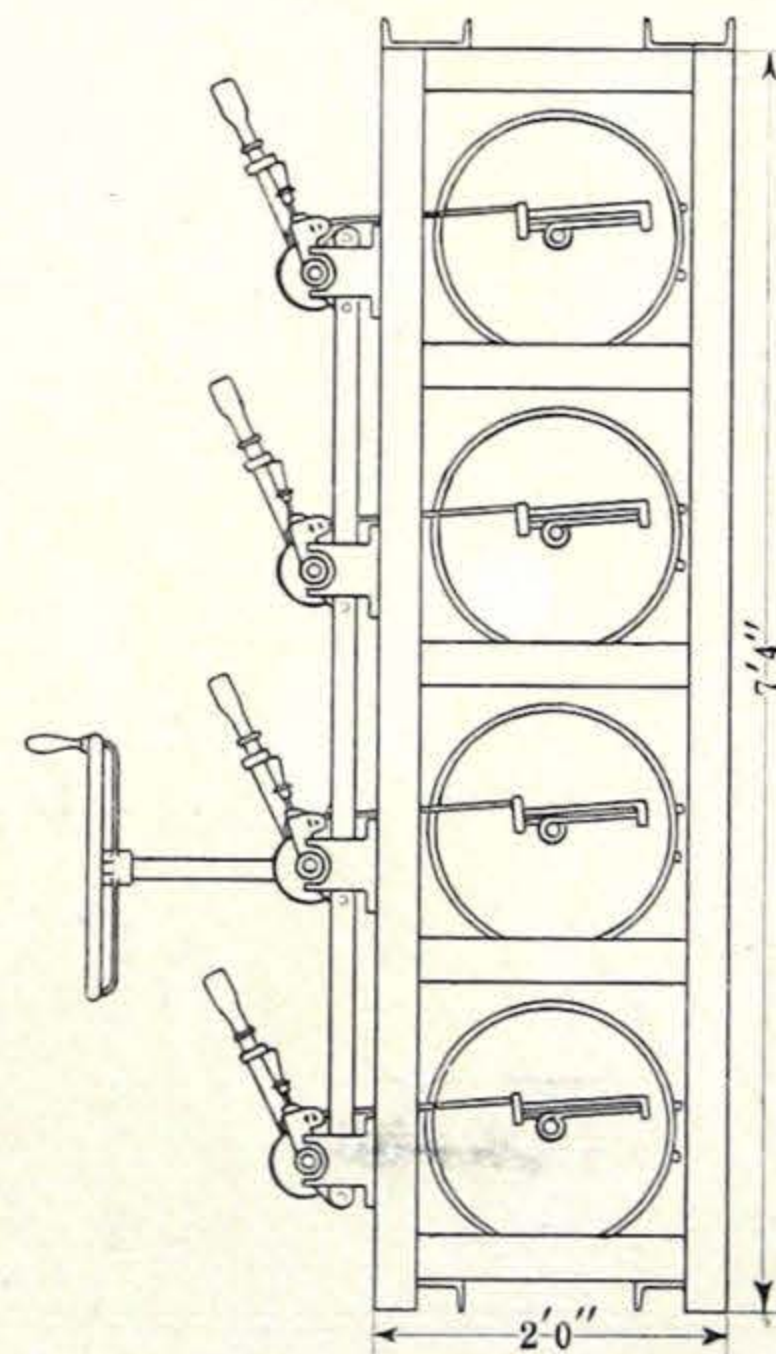

DIAGRAM 14
FLOOR MOUNTING, 3 OR 4 ROWS HIGH,
WITH COLOR MASTER LEVERS AND
SLOW-MOTION CROSS-CONTROL
WHEEL IN CENTER

This is a most advantageous arrangement.

To obtain an approximate length for a bank of this type, multiply the number of plates in the white stage and white house sections by 4.25 inches and add 15 inches.

TYPICAL SPECIFICATION FOR THEATRE DIMMER

(a) On the prompt side of the stage adjacent to the proscenium arch there shall be installed the dimmers listed in the lighting schedule. These dimmers shall be supported in a rigid angle-iron frame in such a manner that no operating handle will be nearer the floor than six inches, nor more than seven feet above the floor, so that the average operator can reach them easily.

(b) The dimmers shall be of the plate type arranged for either individual operation or for interlocking to a color master lever. They shall be arranged in color groups with a master lever for each color in the house and for each color on the stage. There shall also be provided a slow motion cross control wheel and gears with color masters so arranged that color sections may be operated individually, or they may be interlocked to the hand wheel mechanism to raise the illumination of one or more color groups and at the same time dim one or more other color groups.

(c) All feeders or group circuits of 3000 watts or less and the dimmers for them shall be two-wire. Feeders carrying a greater load may be three-wire.

(d) The dimmers shall be the Vitrohm type suitable for continuous operation at their rated load and, after carrying this load at any setting for two hours with natural air circulation, no part of the dimmer shall attain a temperature in excess of 250° C. above the surrounding air and shall not emit smoke, steam or odor.

(e) The resistor for each dimmer shall be divided into not less than 110 steps, and the resistor material and contacts shall be attached to a rigid metal supporting plate. The resistor material shall be embedded in a non-hygro-

scopic heat-conducting insulating material capable of withstanding a temperature of 400° C. without calcining, softening or deteriorating. The movable contacts cutting the resistance in and out of the circuit shall be the skate shoe type with minimum friction consistent with good carrying capacity and long life.

(f) Where the dimmer for a group circuit or feeder consists of more than one plate it will be provided with one common buss for connecting all the plates to the fuse of the group circuit. The other separate terminals of each plate shall be connected with a wire of suitable capacity to separate sections of the branch circuit buss. The separate plates making up the dimmer shall be rated for the capacity of the branch circuits so connected to them.

(g) The contractor shall submit to the architect (or engineer) a drawing showing the proposed arrangement of the dimmer and switchboard which must be approved by him before construction work is started.

(Insert the following clause in the magazine panel specification.)

(h) These fuse panels shall be bussed for connection to the group circuits outlined in the schedule and where the dimmer for the group circuit or feeder consists of more than one plate the buss for this group circuit shall be divided to distribute the load on the separate plates.

The Ward Leonard Electric Company have on their technical staff experts on theatre illumination and lighting control who will be glad to co-operate with those interested and furnish them with suggestions.

A TYPICAL LIGHTING SCHEDULE

CIRC. NO.	LIGHTS CONTROLLED	LAMPS			MAG. BRANCH CIRCS.	DIMMERS		SWITCHES	
		NO.	WATTS	TYPE		WATTS	MASTER	POLES	MASTER
1	White Foots	35	200	C	6	7000	White Stage	2	White Stage
2	" Prosc. Strips	16	100	C	2	3200			
3	" Border No. 1	18	400	C	5	7200			
4	" " " 2	18	400	C	5	7200			
5	" " " 3	18	400	C	5	7200			
6	" " " 4	18	400	C	5	7200			
7	" " " 5	18	400	C	5	7200			
8	" " " 6	18	400	C	5	7200			
9	Incand. Pockets	-----	-----	-----	8	8-2000		3	
10	" "	-----	-----	-----	6	6-2000		3	
11	Arc "	-----	-----	-----					

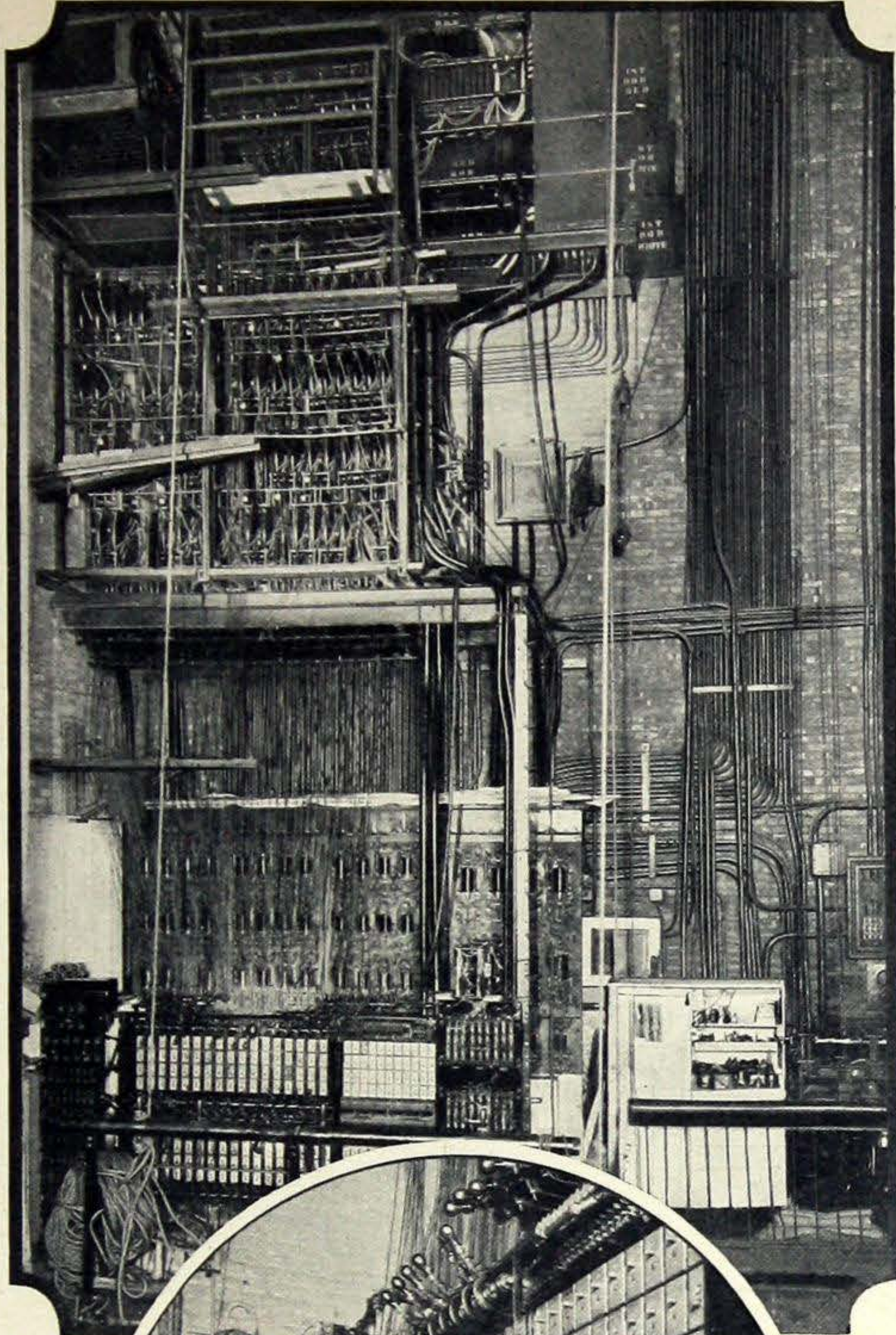

The Ward Leonard Dimmer shown, which controls the 5,000 amperes required for lighting effects in the famous New York Hippodrome, was installed years ago. There is a total connected load on this equipment of 10,000 amperes (three-wire, direct current).

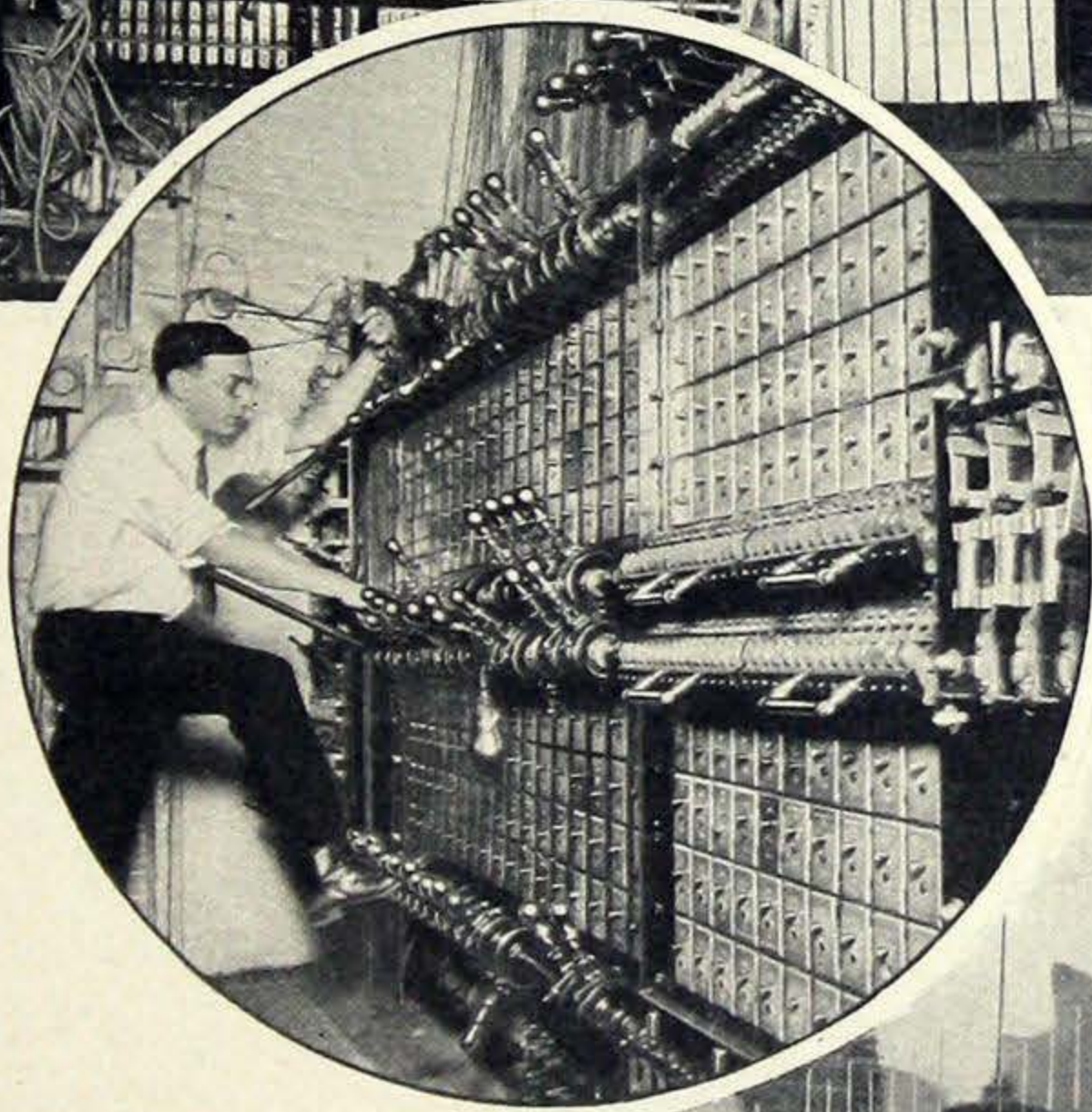

Close-up of the panel shown in the lower part of the picture above.

New York Hippodrome.



The name Vitrohm has been used in the specifications, because it represents in a definite and positive way a metal plate construction in which vitreous

enamel and resistor material are applied in accordance with experience of more than thirty years in the manufacture of this type of apparatus.

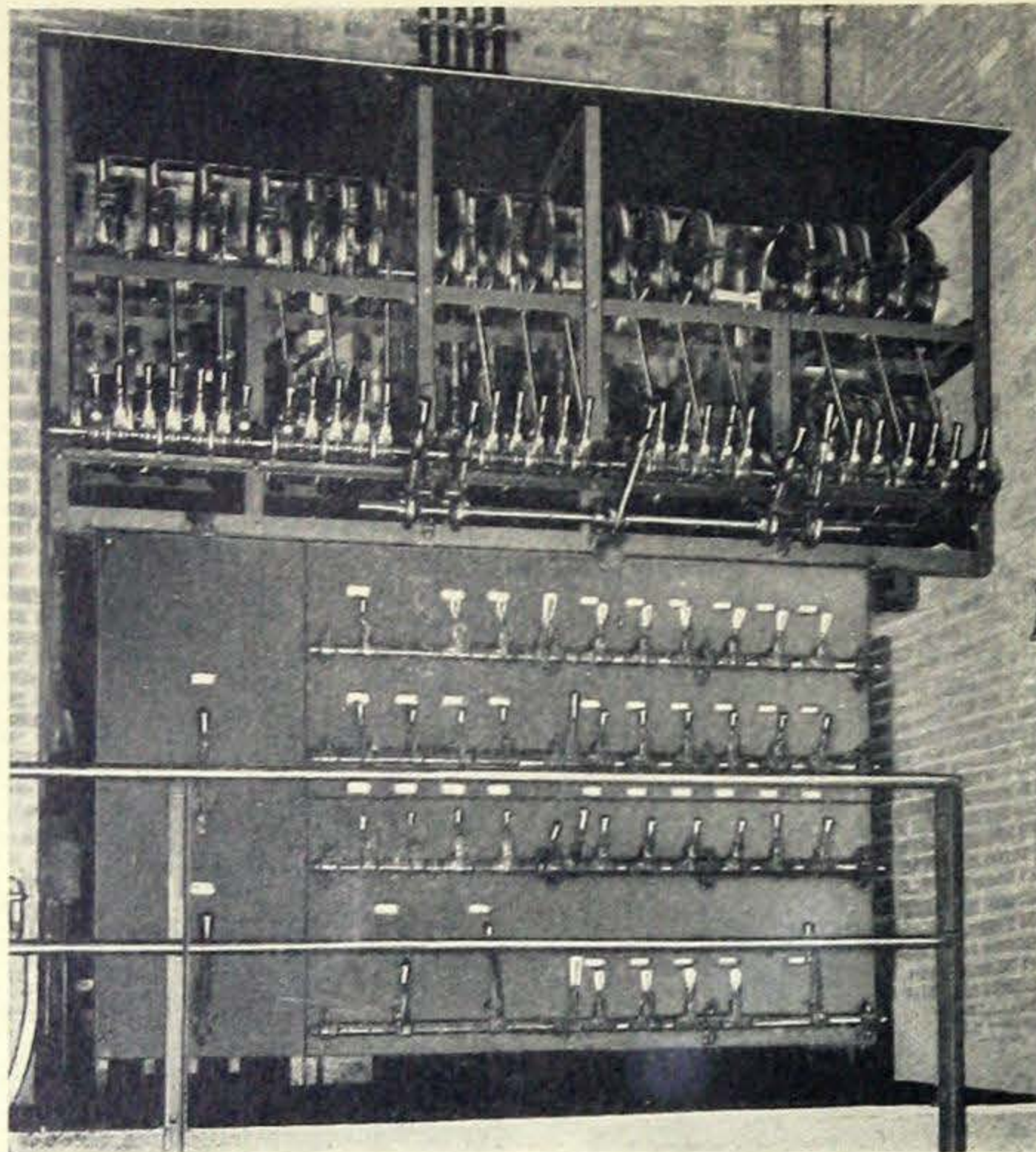

Figure 47 — Ward Leonard Dimmers (top of board type) installed in the National Theatre, New York City.

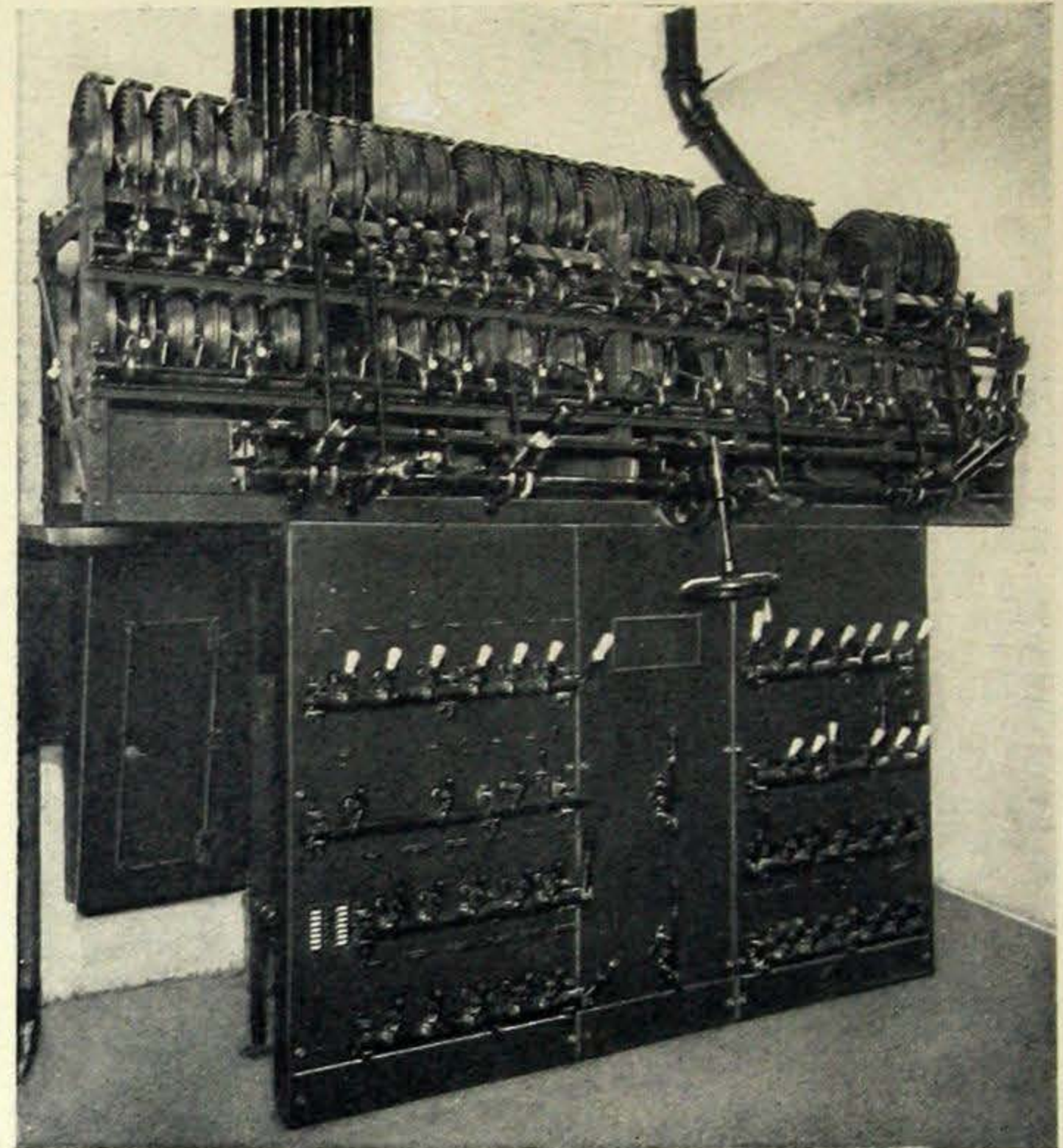

Figure 48 — Ward Leonard Dimmers installed in Loew's 83rd Street Theatre, New York City.

BASIC FACTORS IN DIMMER INSTALLATION DESIGN

When requesting proposals for dimmer equipment, the manufacturer should be furnished with the following information:

1. Voltage of lamp circuits.
2. Whether dimmers are to be connected to two or three-wire circuits.
3. The circuits to be controlled must be listed and the name of each indicated, so that the dimmer handles may be furnished with proper nameplates.
4. The number of watts per dimmer and for multiple plate dimmer the number of watts on each plate.
5. The type of dimmer control: independent handle interlocking, cross interlocking or remote control.
6. If interlocking or cross interlocking dimmers are to be used, the general arrangement including the number and position of master handles should be indicated by means of a rough sketch.
7. If the dimmers can be arranged in some standard form such as shown on page 43, it will be sufficient to indicate the arrangement by reference to the respective diagrams.
8. The dimensions of space available for the dimmer should be given.
9. The lamp load carried by any dimmer may comprise several sizes of lamps providing the maximum capacity of the dimmer is not exceeded.
10. Where equipment is unusual, any requirements in addition to the above should be fully specified.

The typical floor plan for stage lighting as shown on page 58 may be helpful in considering the general problem of lighting.

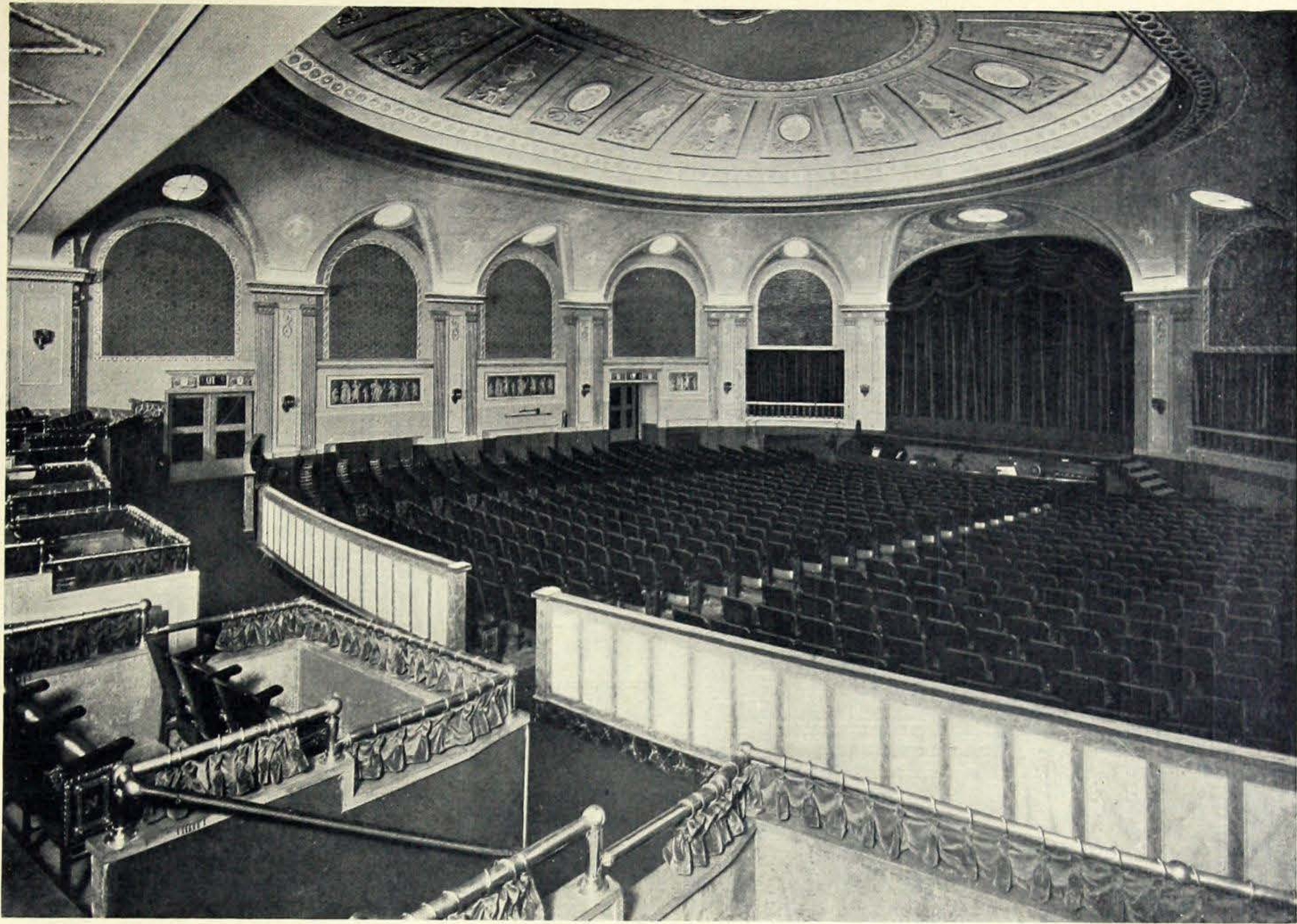

Interior of the National Theatre, Brooklyn, N. Y.

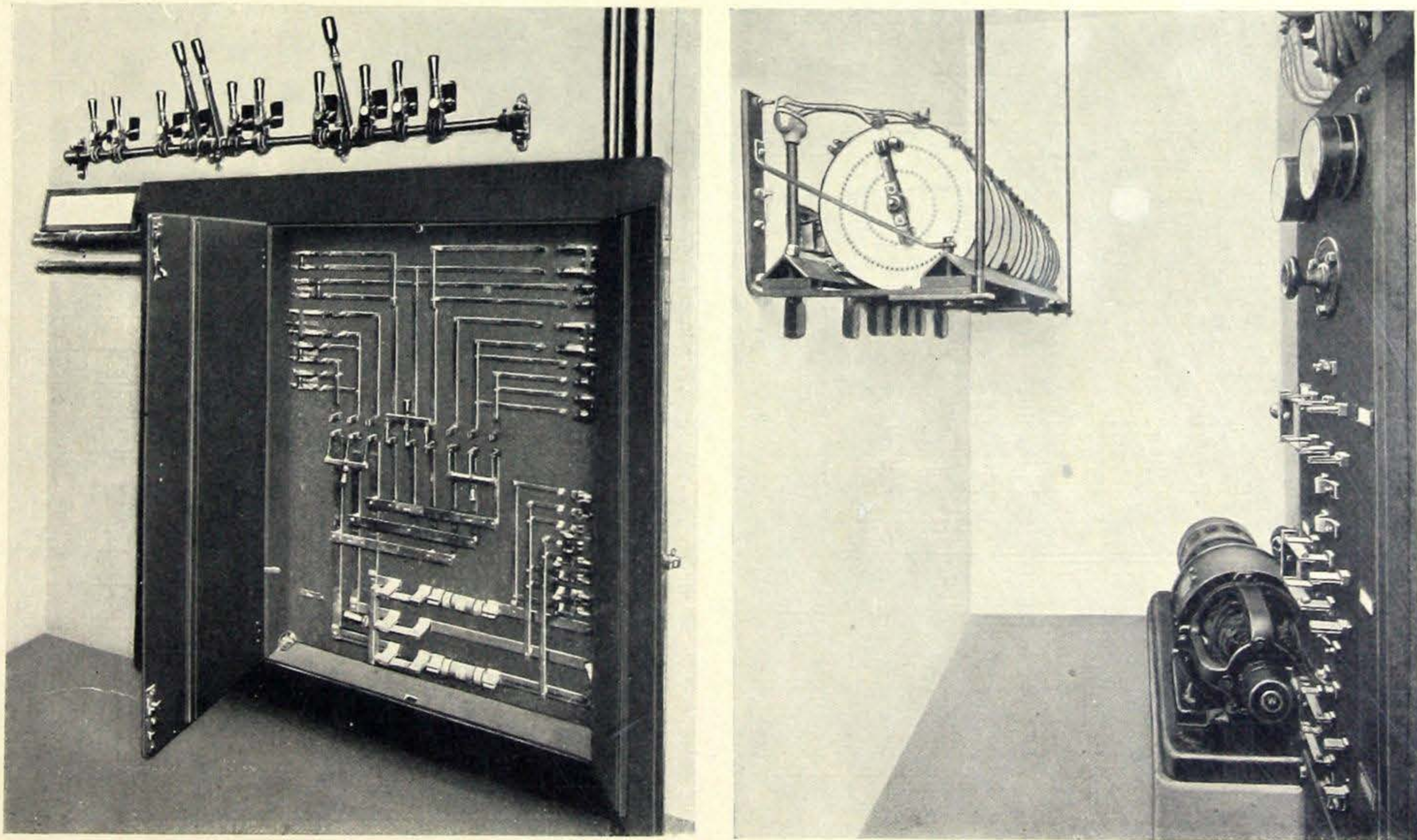

At the left are shown the operating handles of the Ward Leonard Dimmers installed in the National Theatre in Brooklyn. The plates are on the opposite side of the wall as shown at the right in a separate room with the motor generator set

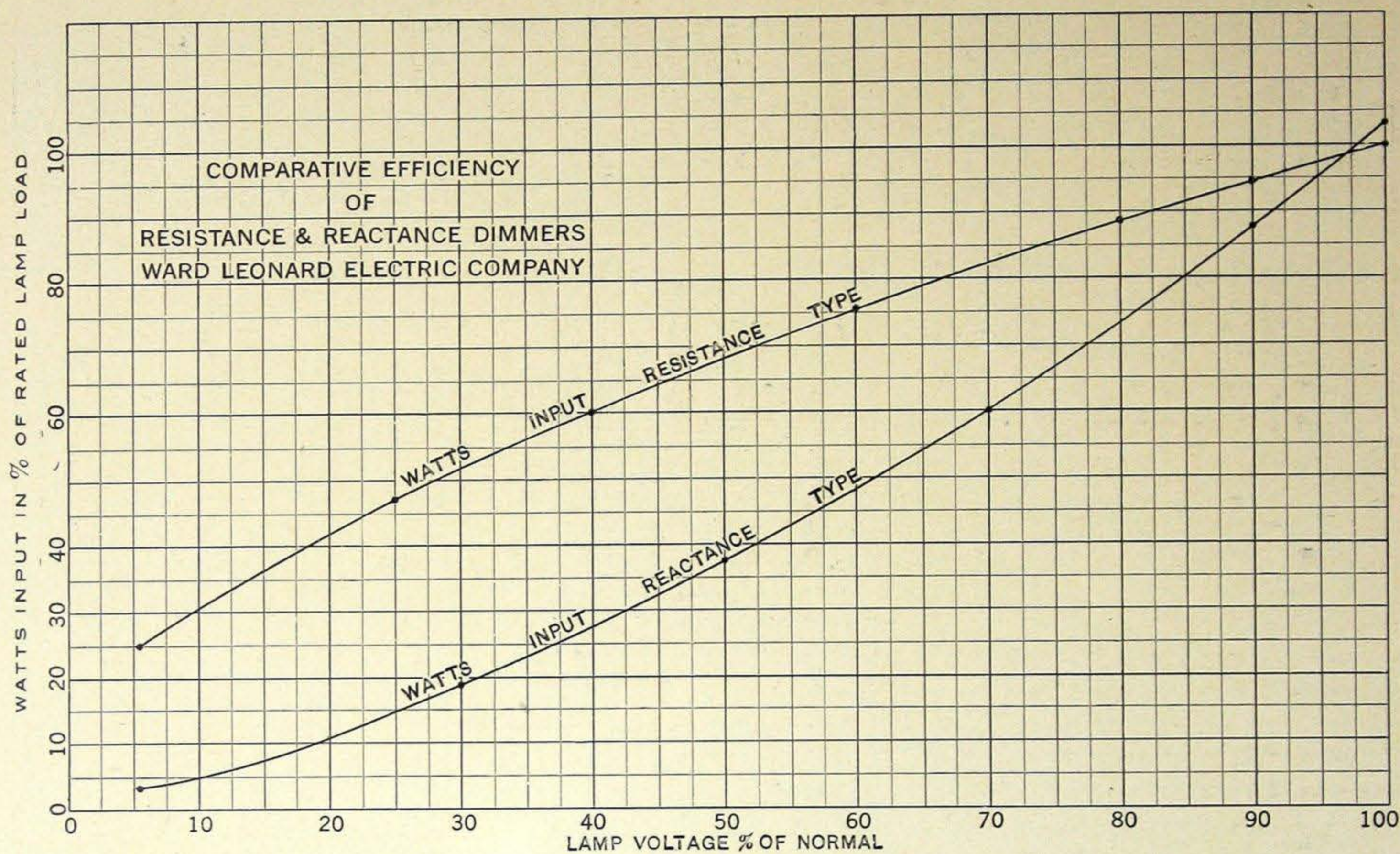

The curve above shows the comparative efficiency of resistance and reactance dimmers with different voltages at the lamp, while the one below shows the candle-power at different voltages. From these curves it will be noted that a distinct saving in energy can be effected by the use of reactance dimmers; also that their use is justified in installations where the dimmer is in service for long periods.

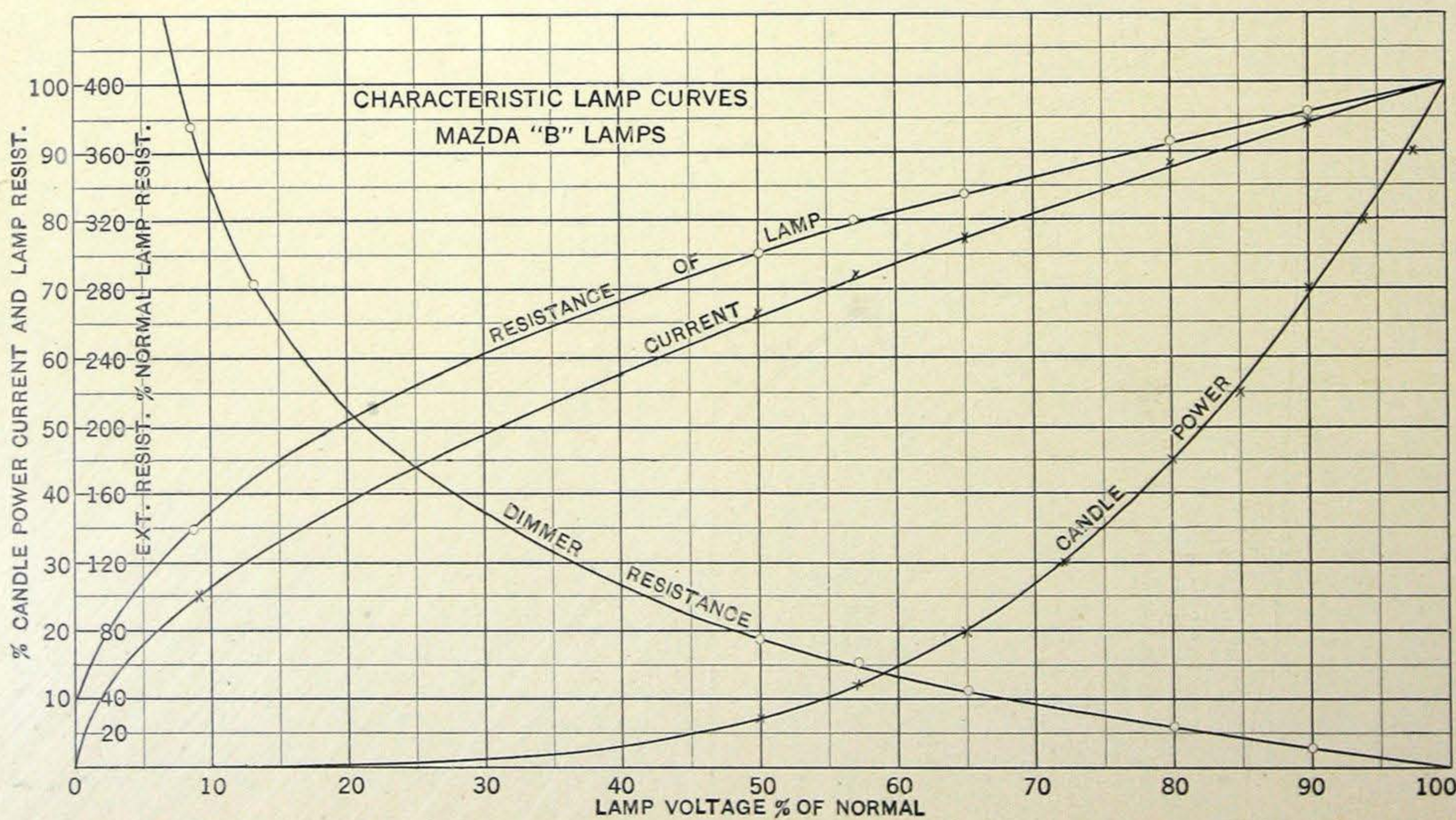

WARD LEONARD REMOTE-CONTROL DIMMERS

In large installations the space required for dimmer equipment is often not available at a point where the control board should be situated. One solution of this space problem is the motor-driven dimmer located at any point where the space is available, and controlled by miniature switches from the control board.

The original form of remote-control dimmer employed by the Ward Leonard Electric Company was motor driven as shown in Figure 31 reproduced from the catalog of the Ward Leonard Electric Company issued in 1892. Improved forms of the early motor-driven dimmer are still furnished where required. In such installations each plate or group of plates is connected to a separate motor through a worm reduction gear and controlled by push-button stations located at the control board on the stage. Substantial positive-acting limit switches prevent over-running in case the operator does not shut off the motor. The motor circuits are manipulated by magnetic switches or contactors mounted on a panel carried on the dimmer frame.

REACTANCE DIMMER

A better solution of the remote control problem is provided by the reactance dimmer, a recent Ward Leonard development. This consists of a Vitrohm plate and a reactor. In this dimmer, adjustable reactance is utilized to control the flow of electricity to the lamps—the reactance being varied by means of a standard Vitrohm plate handling a current of less than two per cent. of that required by the lighting circuits which it controls.

By this new system a small Vitrohm plate for each circuit with standard hand levers and slow-motion control

are the only parts of the dimming plant which need be installed on the stage. The reactors which handle the main circuits to the lamps may be located wherever space is available. In this way, the actual control equipment, which should be located at a point on the stage where the operator can follow the action, is reduced to the smallest possible dimensions, and entirely within the limits imposed by modern construction.

PRINCIPLE OF THE REACTANCE DIMMER

The reactor used is of a closed circuit type having two A. C. coils and a D. C. coil. By varying the current in the D. C. coil by means of a small Vitrohm plate, the voltage at the lamp is varied from full brilliance to black out.

The direct current for controlling these reactors, if not available from existing sources, may be furnished by a small motor-generator. The amount of power required is approximately one per cent. of that used in the main circuits. Among the installations of this character are the two largest dimmer installations in the world (illustrated on pages 50, 51 and 52).

The control board of Grauman's Metropolitan theatre shown on page 52, is the most compact of any ever built. While it controls 135 feeder switches and the dimmers regulate the lighting load of 650 kw., it is only about 13 feet long, and is installed in a recess of the prompt side of the proscenium arch. The remote switchboard is installed directly under the stage in the basement. At the rear of this board are mounted the reactors, which are controlled by the Vitrohm plates on the control board (shown at top of page 52).

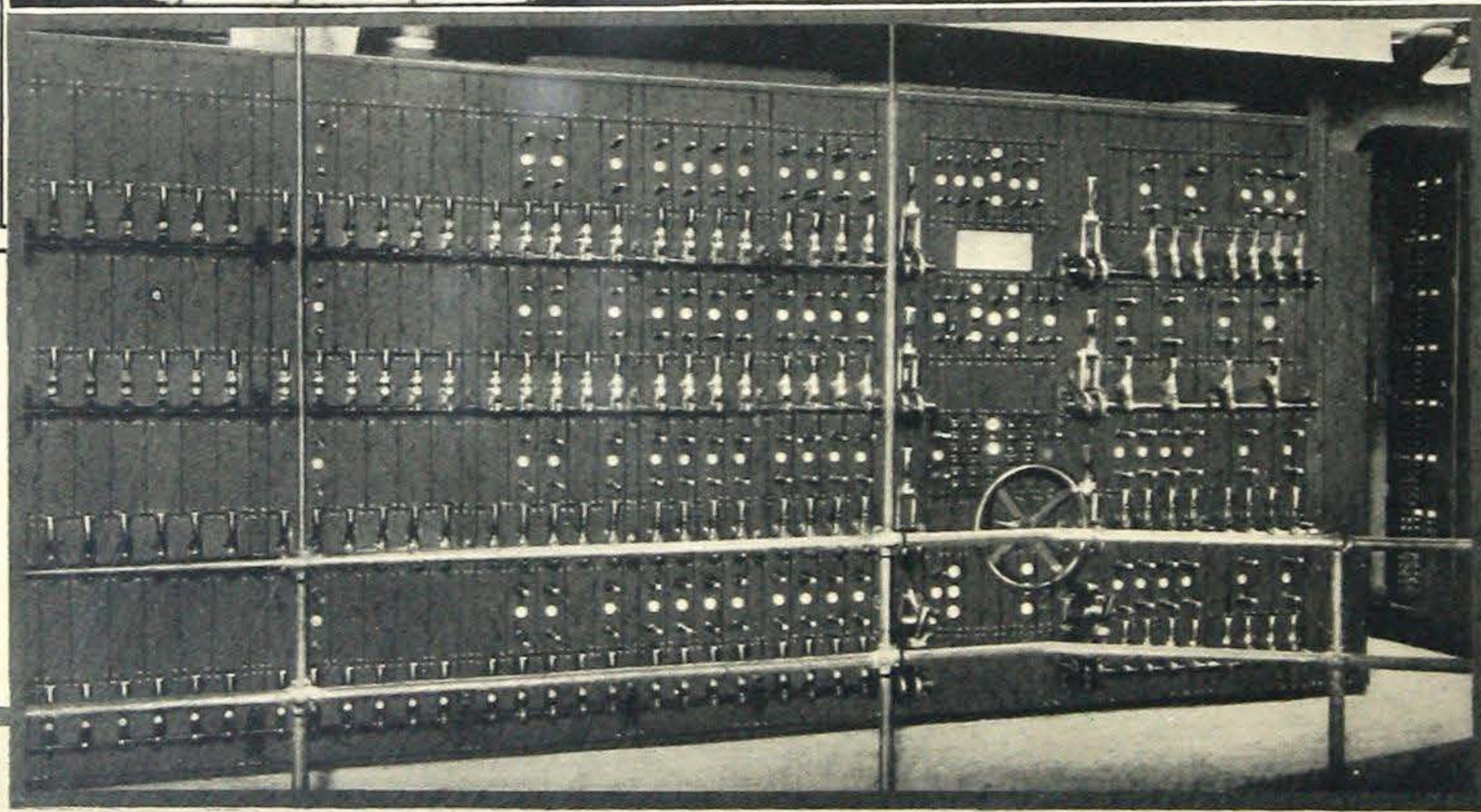
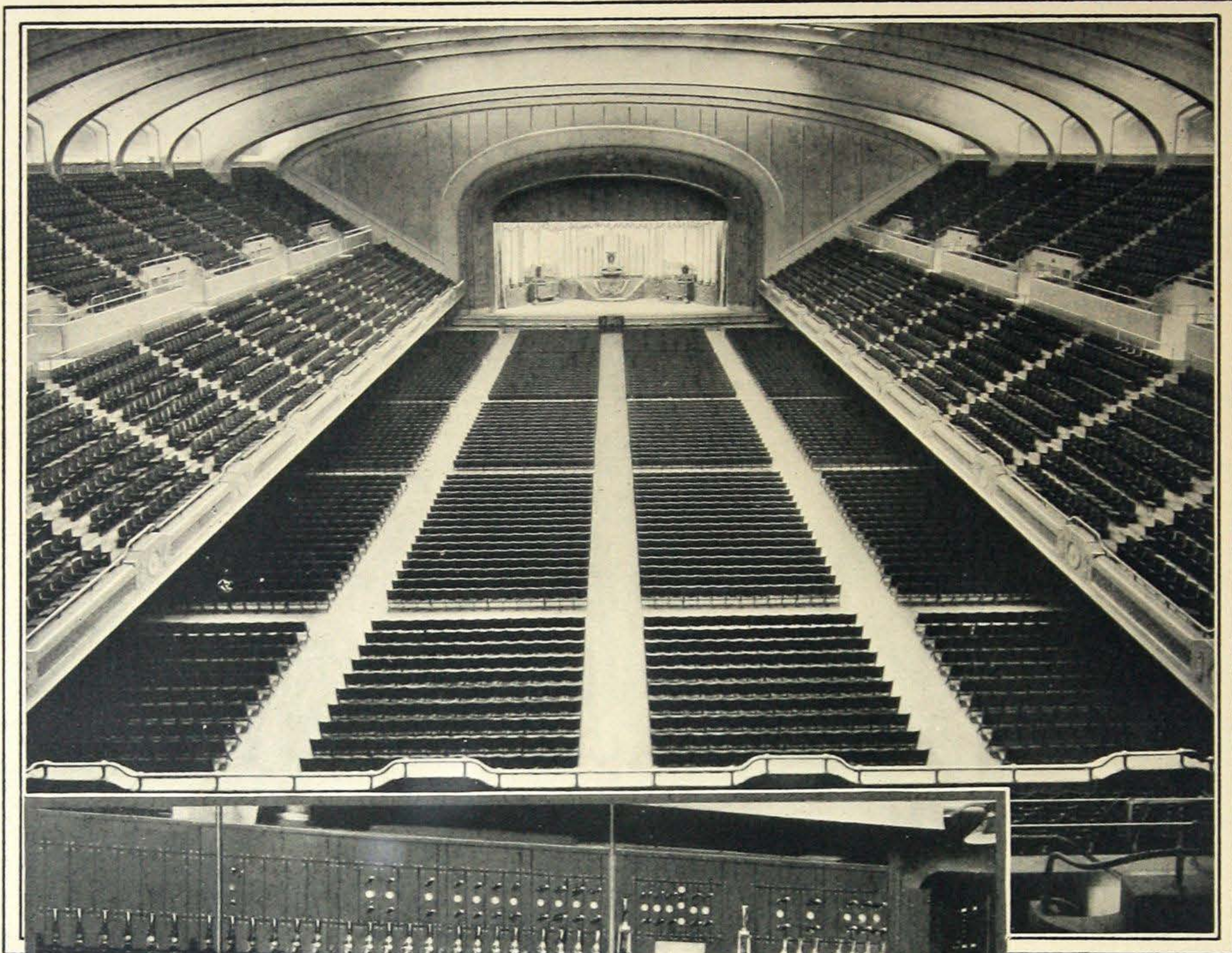

Interior Cleveland Auditorium.

Exterior Cleveland Auditorium. The Dingle-Clark Co., contracting engineers.



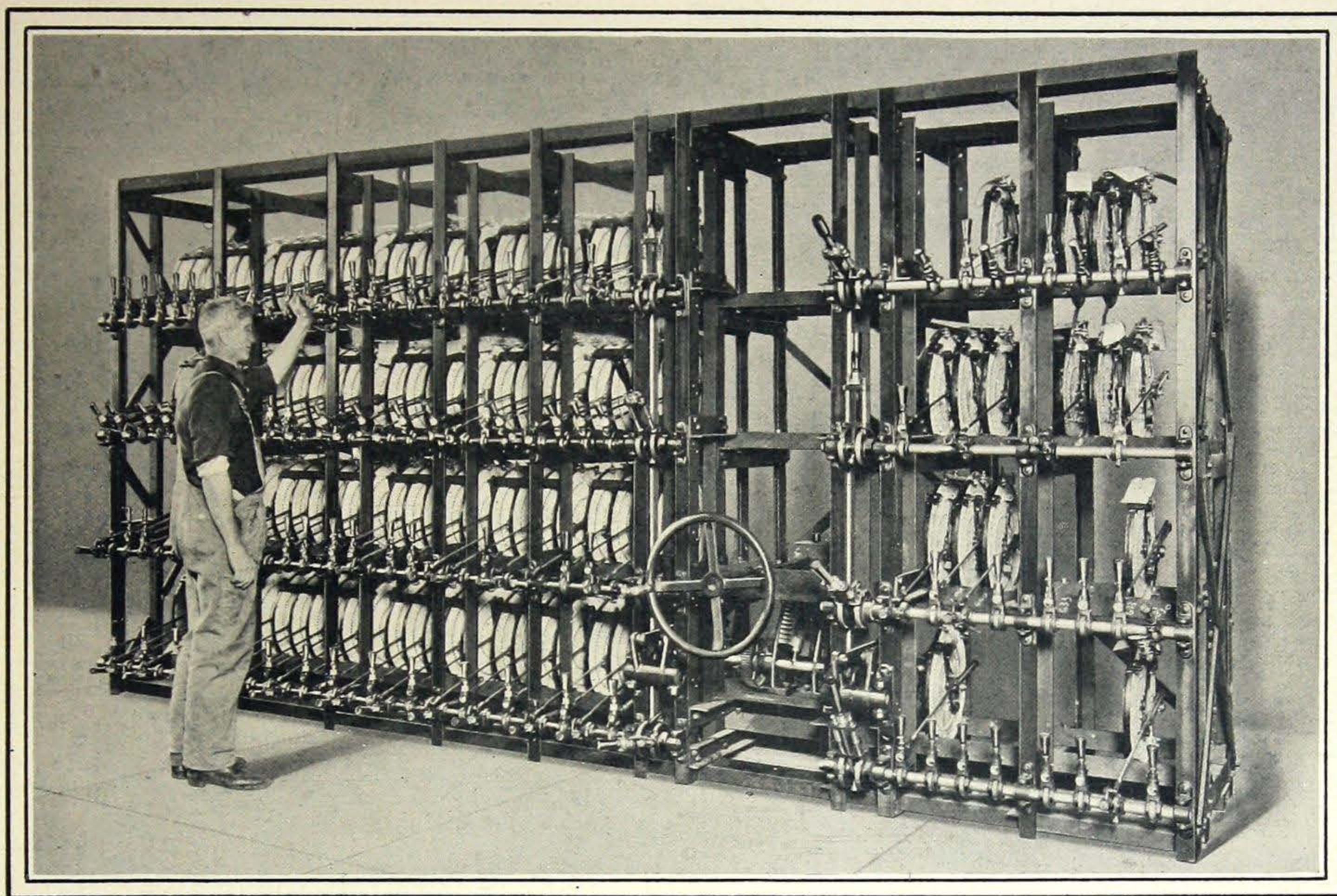

Bank of Ward Leonard Vitrohm plates, controlling the reactance dimmers shown below. The center picture on the opposite page shows this pilot dimmer with the pilot switches and steel front added. This is the largest and finest auditorium in the United States, having a seating capacity of 12,000 persons. The dimmer is the largest in the world. Total load connected to dimmers, 900 kw. The pilot board shown in the center of opposite page controls the contactor board in the basement. This was built by the Cleveland Switchboard Company.

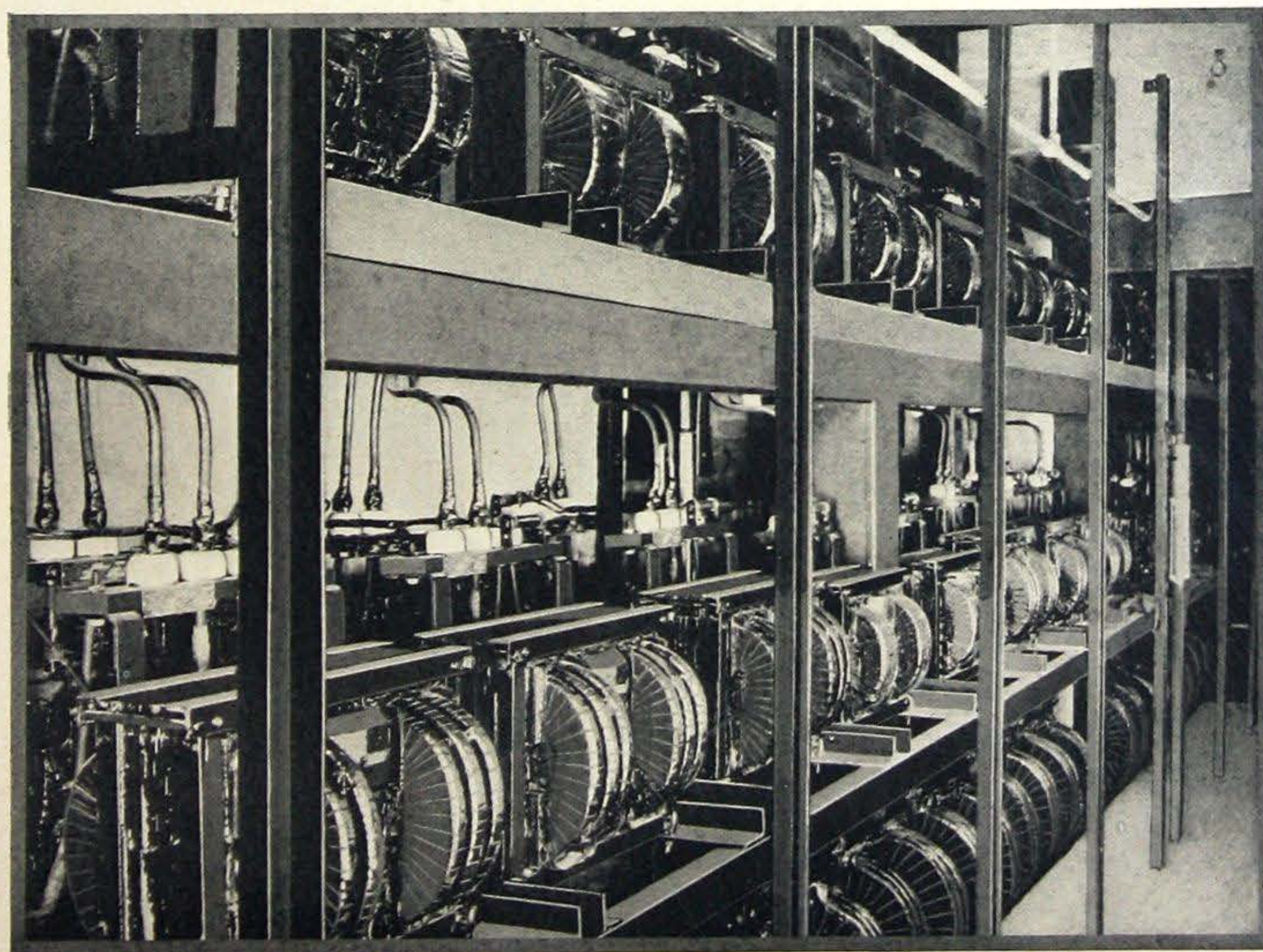

The Ward Leonard Reactance Dimmers installed at the rear of the contactor board in the basement of the Cleveland Auditorium. These are controlled by the bank of Vitrohm plates, shown above, and regulate the lamps of stage and house from full brilliancy to black out. This is the first installation of its kind and has been in operation for about one year, giving perfect satisfaction.

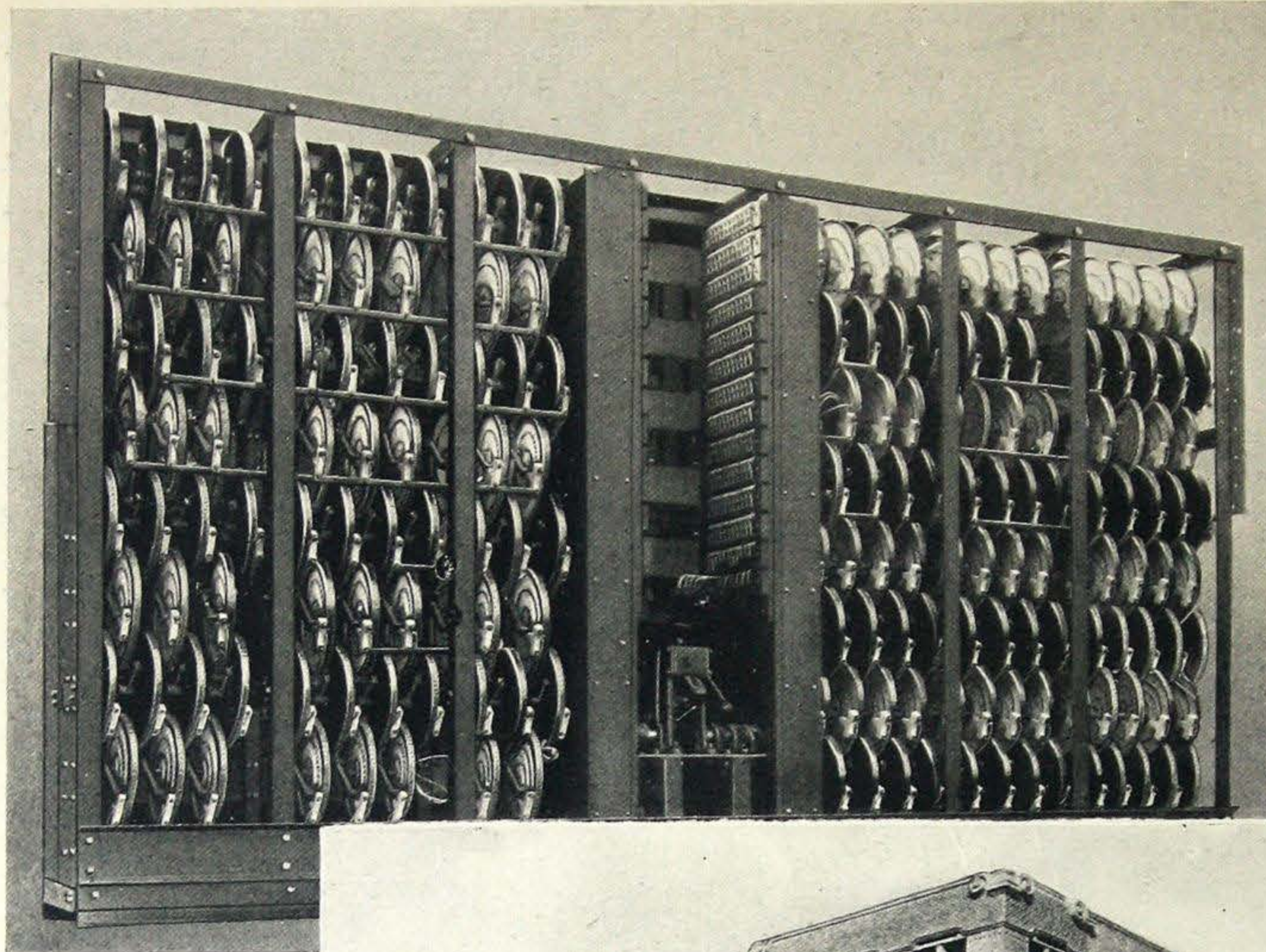

Vitrohm plates on the rear of the pilot board, shown at bottom of this page.

Grauman's Metropolitan Theatre, Los Angeles, designated on the coast as the "Show House of the World." Holmes and Sanborn, Consulting Engineers.



Pilot dimmer and switch-board controlling, by means of Ward Leonard Reactance Dimmers, the largest lighting load of any theatre — 650 kw. The pilot switches shown control a Hub Electric Company Remote Switchboard in the basement.

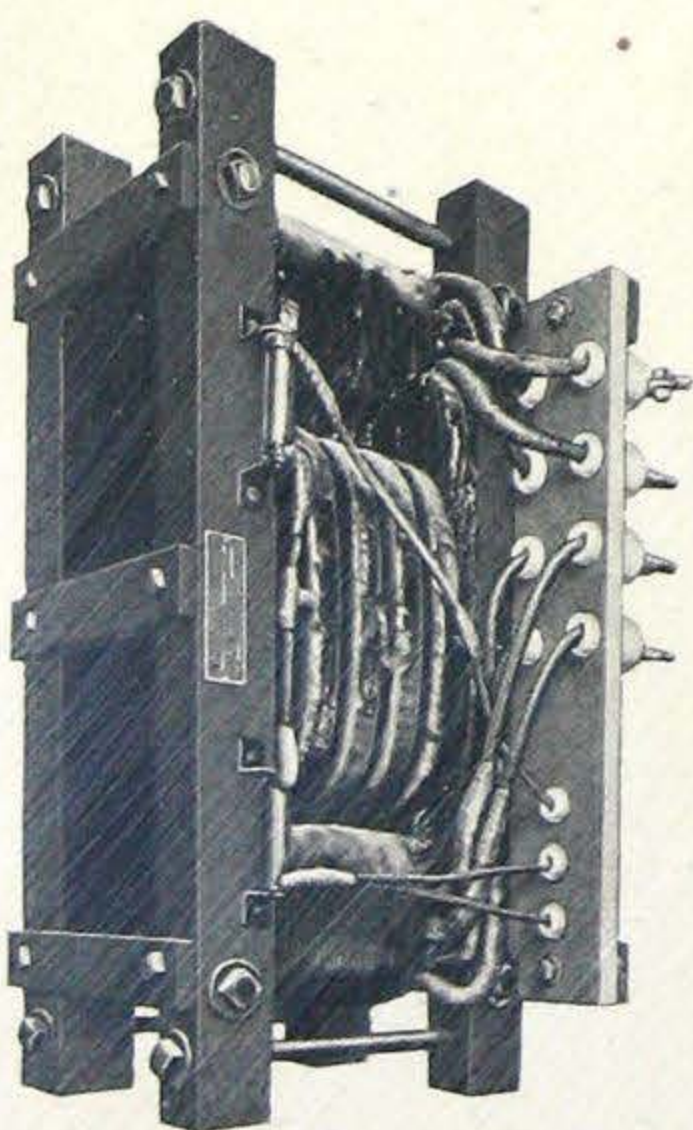

Ward Leonard Reactor.

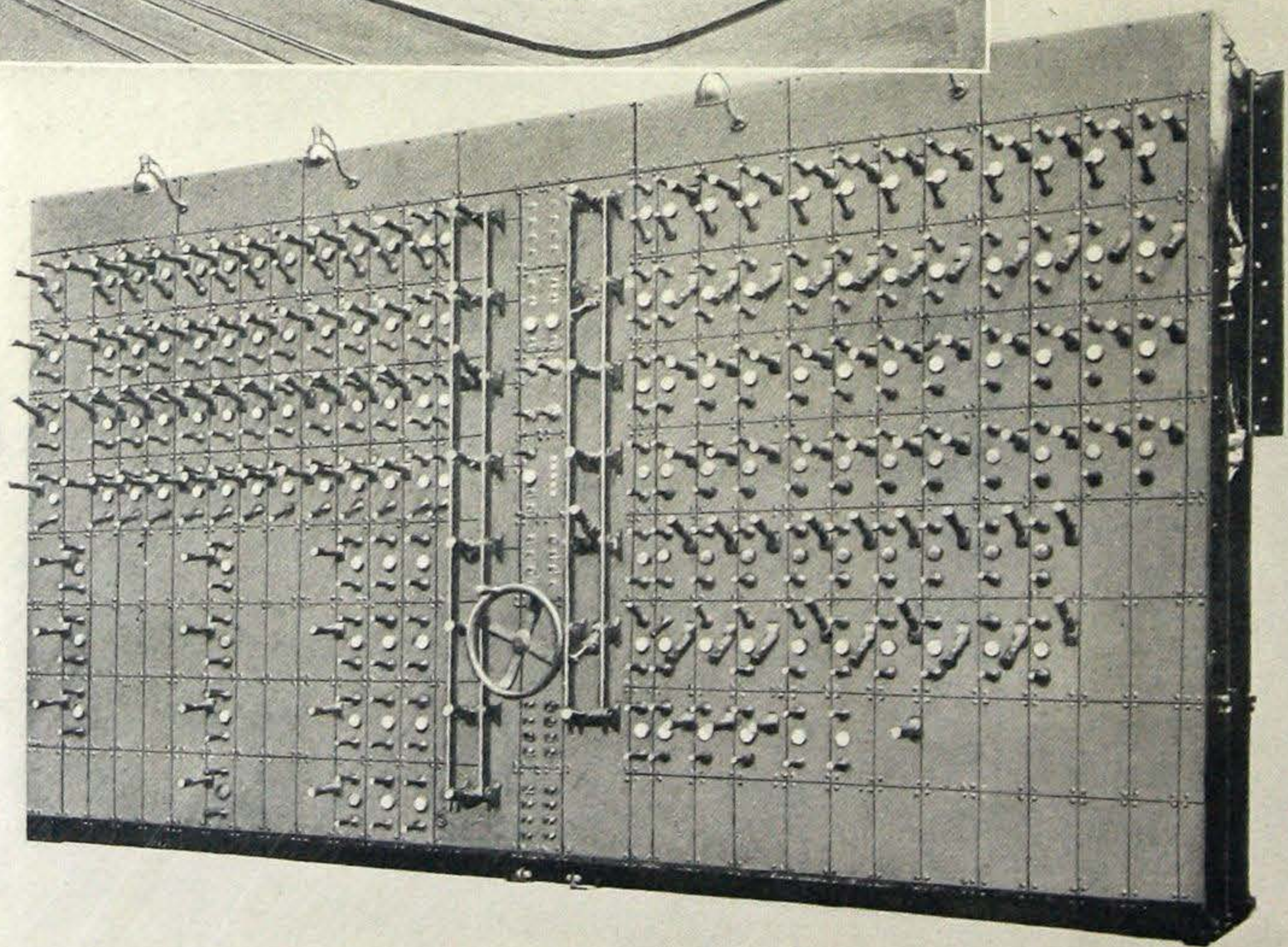

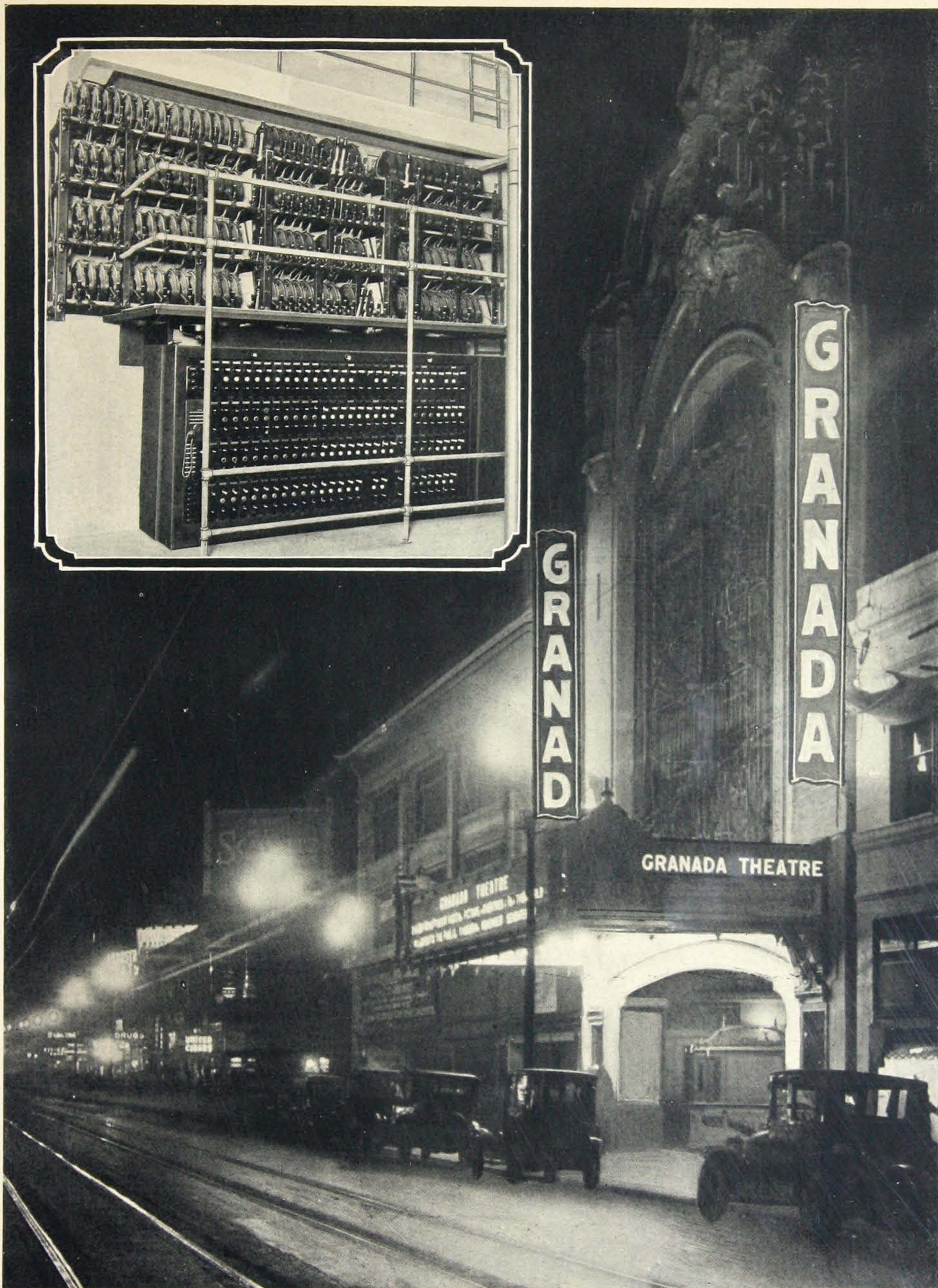

Granada Theatre. San Francisco. One of the recent installations of Ward Leonard Dimmers on the coast; 370 kw. lighting load, controlled by the dimmer equipment shown in the insert picture.

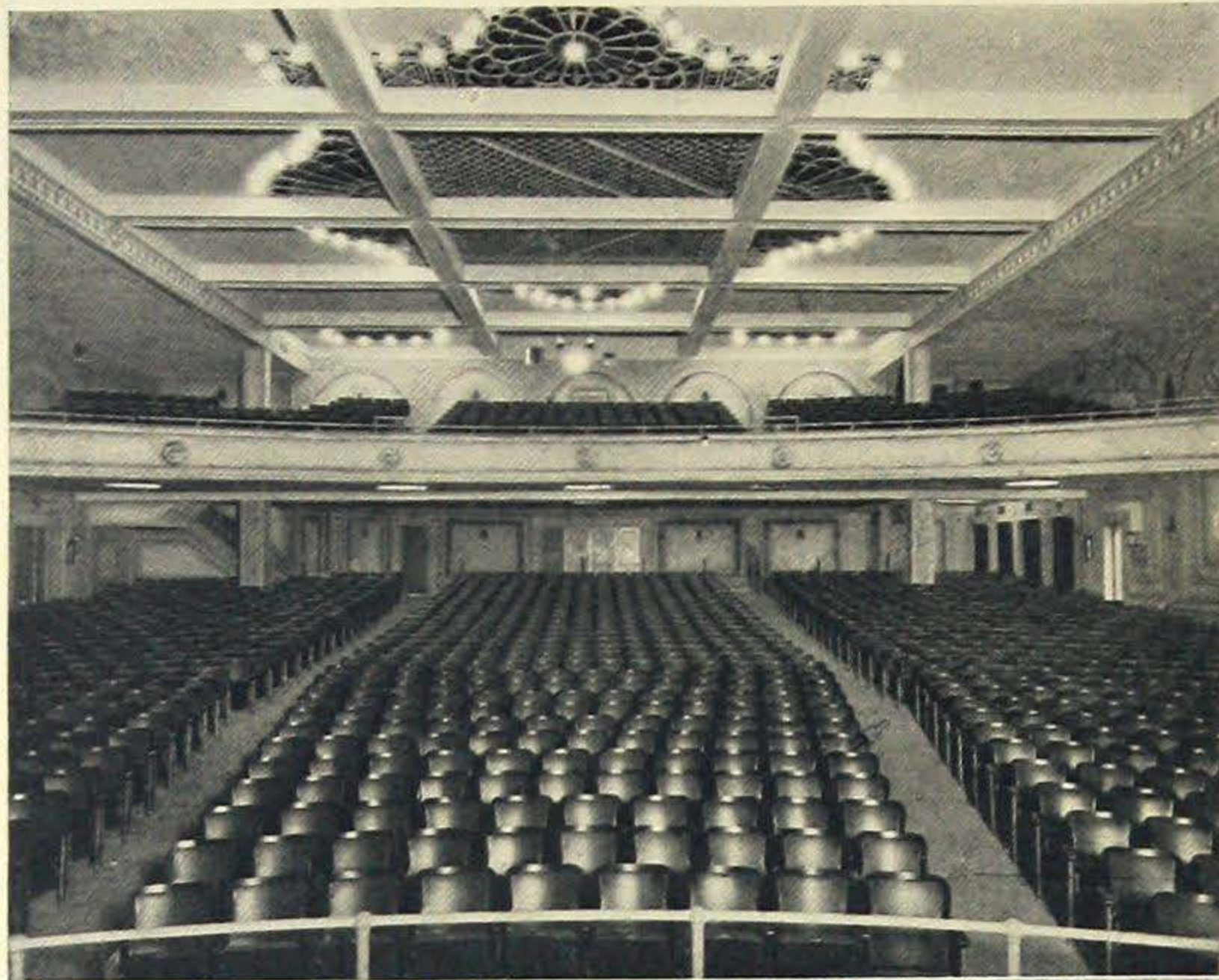

Auditorium of Castles by the Sea Theatre. Vitrohm dimmer bank and switchboard shown below.

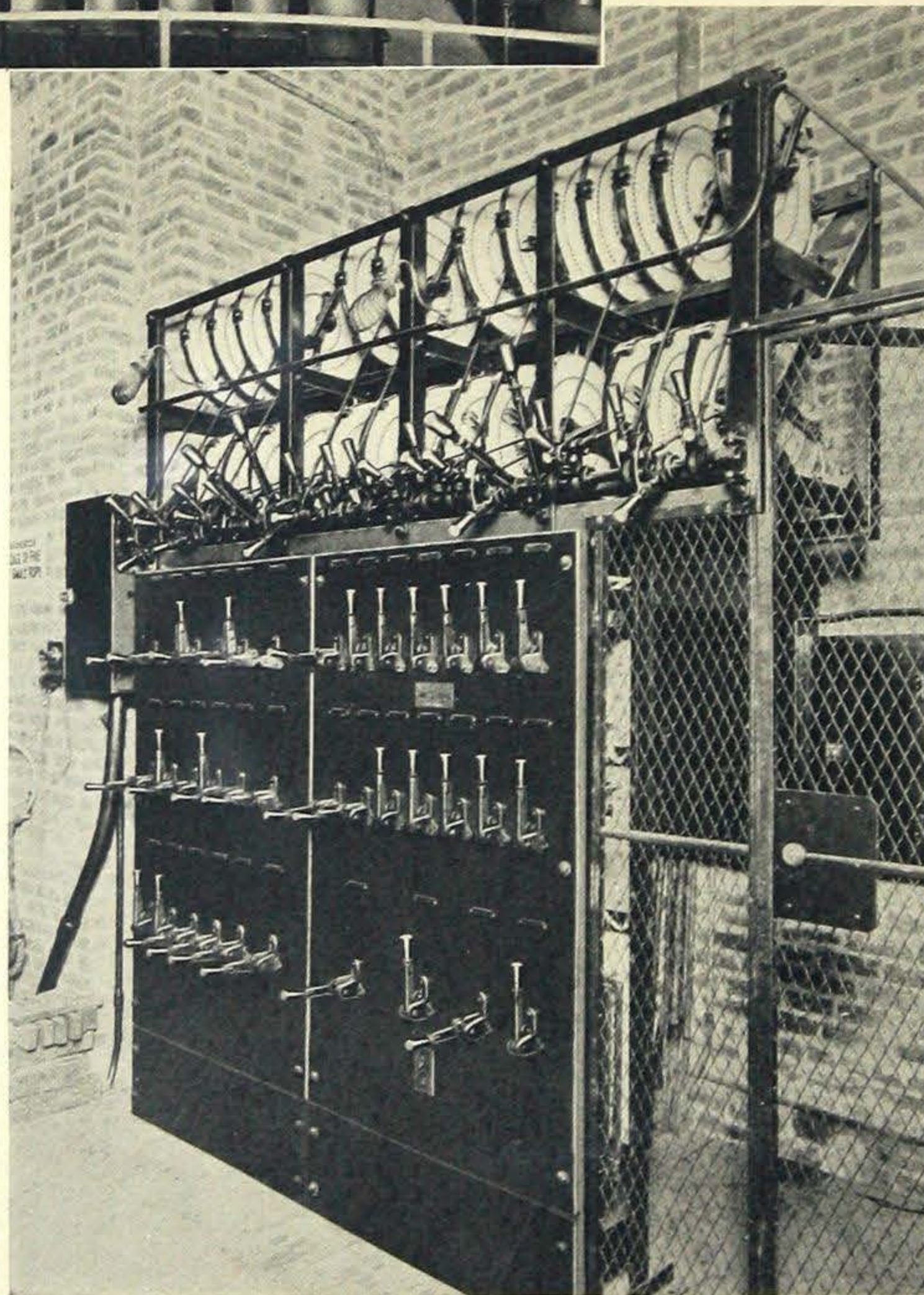

Castles by the Sea, at Long Beach, L. I., is one of the many dining, dancing and amusement palaces where Vitrohm dimmers are depended upon under all of the conditions of service usually existing at seaside resorts.



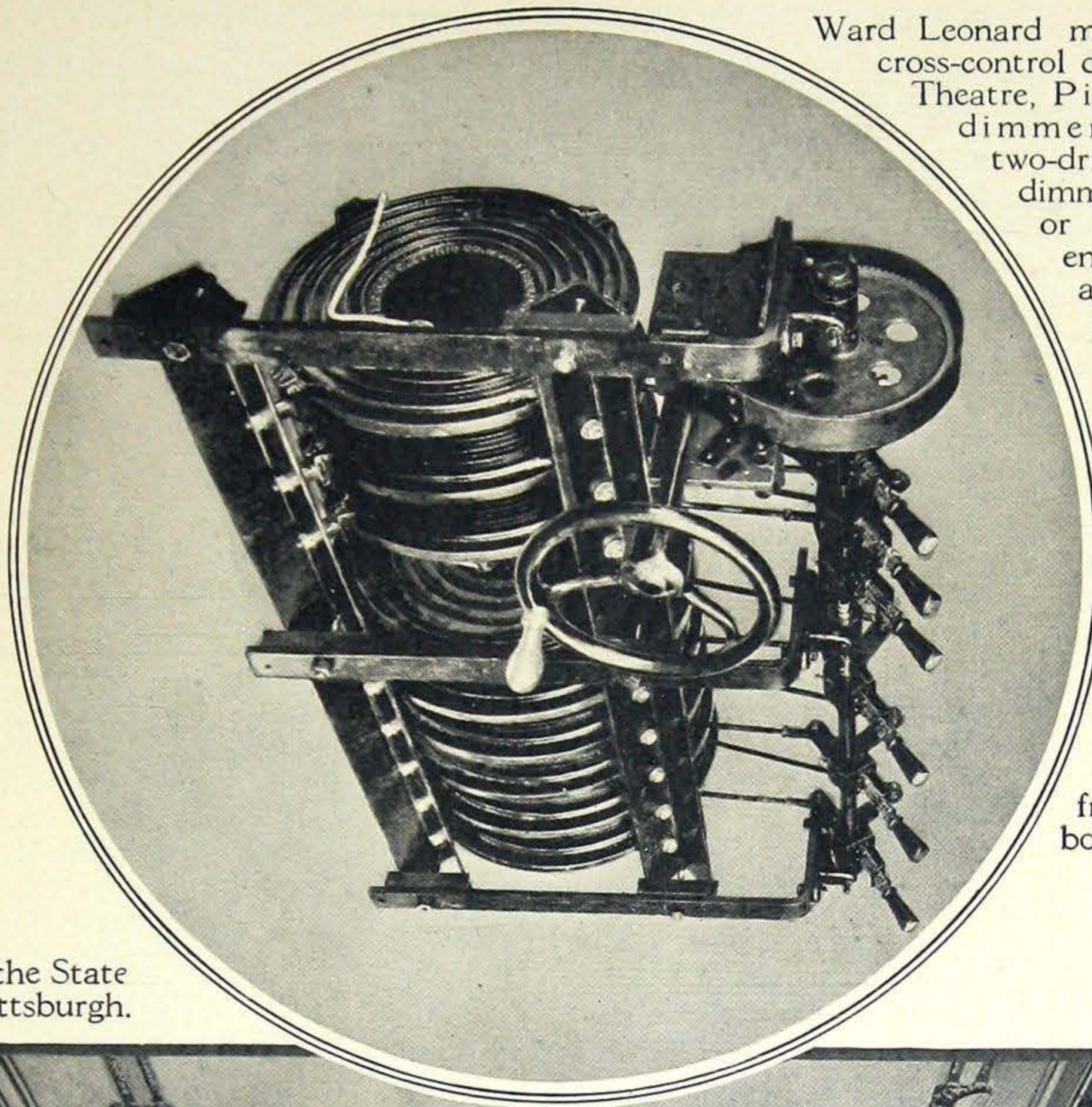

Ward Leonard motion picture type cross-control dimmer in the State Theatre, Pittsburgh. Each dimmer is equipped with two-drive rods so that each dimmer can be set to dim or brighten independently of all the others and all can be operated as set from the one slow motion wheel. This permits the dimming of any particular group simultaneously with the brightening of any other group. The compact arrangement made possible in this construction has many important advantages for control from the projection booth.

Interior of the State Theatre, Pittsburgh.

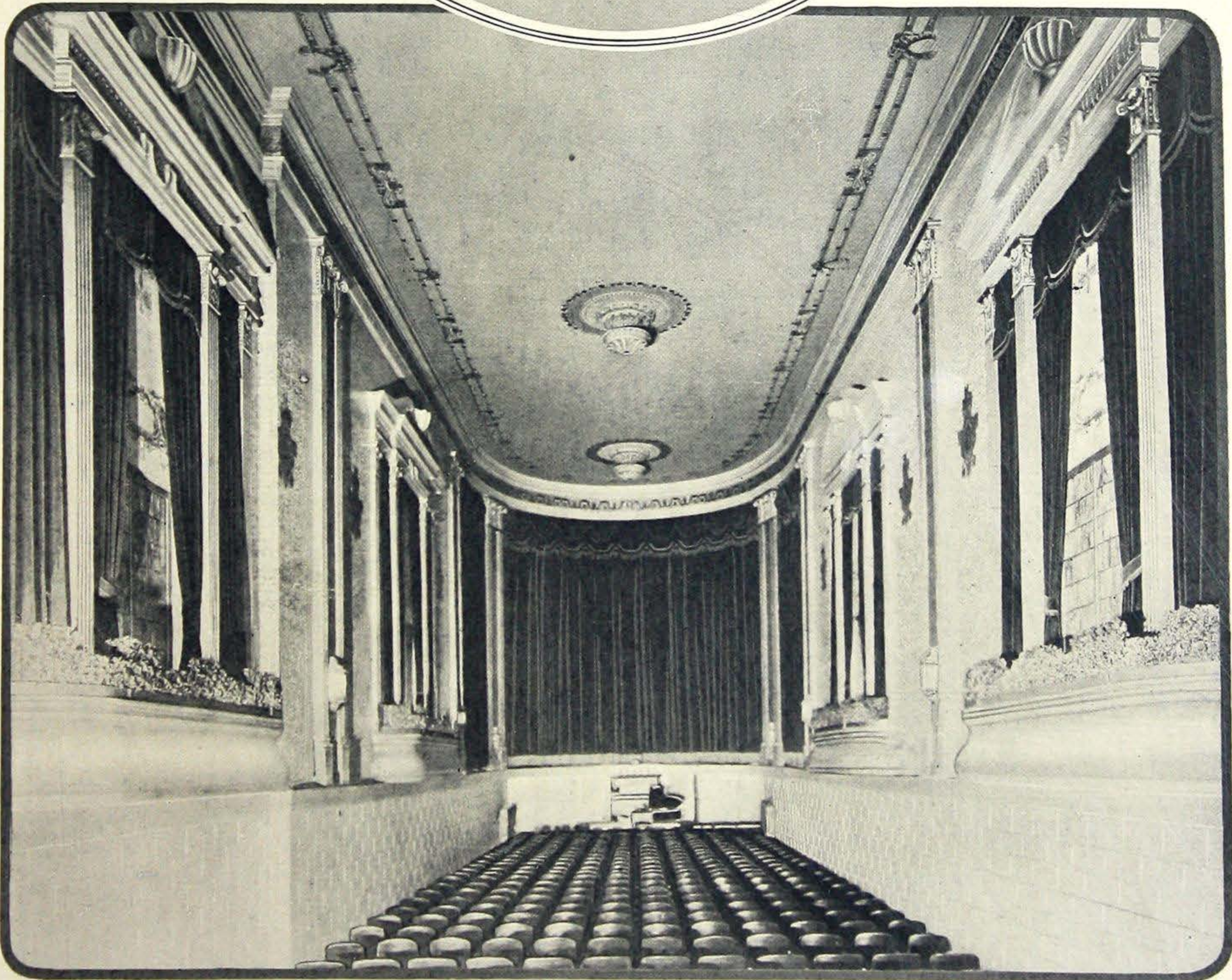



When Mr. George Eastman built the Eastman Theatre for the people of Rochester, he built for permanence — permanence in service. Hence, Vitrohm Dimmers for controlling upwards of 200,000 watts in lamp load were installed in this wonderful institution.

The Vitrohm dimmer installation is shown at the right. A rear view of the dimmer bank is shown below.

The installation picture at the right shows the Ward Leonard "pre-set" as used on these dimmers. This arrangement permits the setting of the operating lever so that it either "drops in" or "drops out" at the preset position, thus leaving the predetermined amount of dimmer resistance in the circuit.

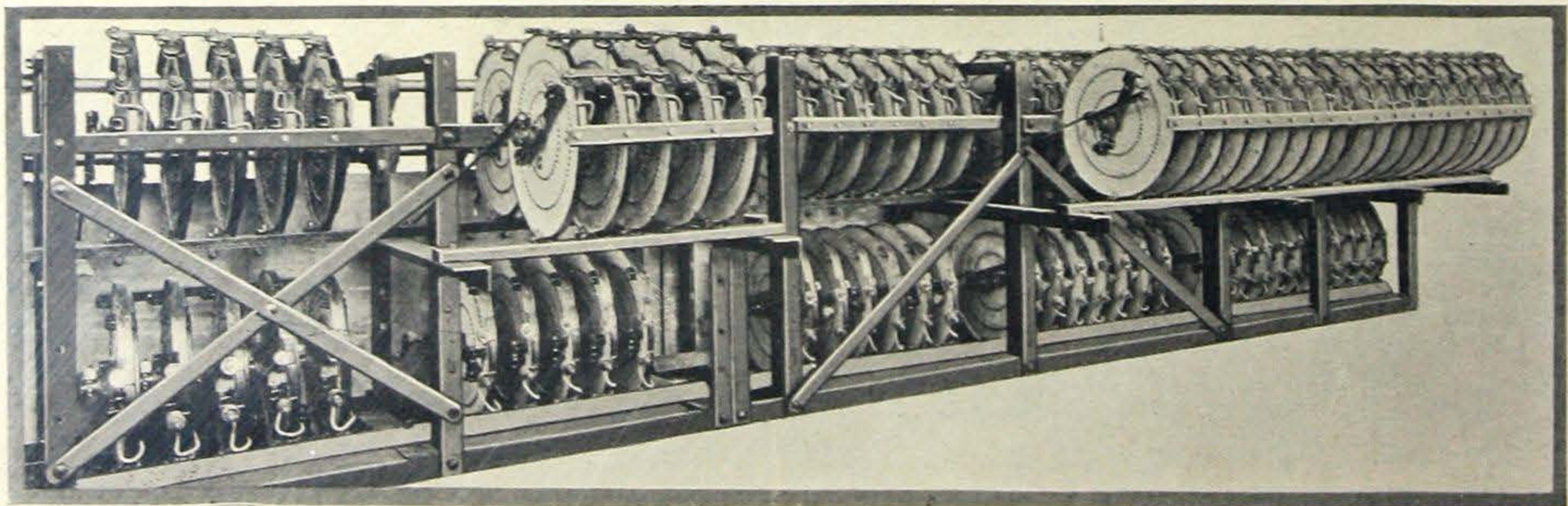
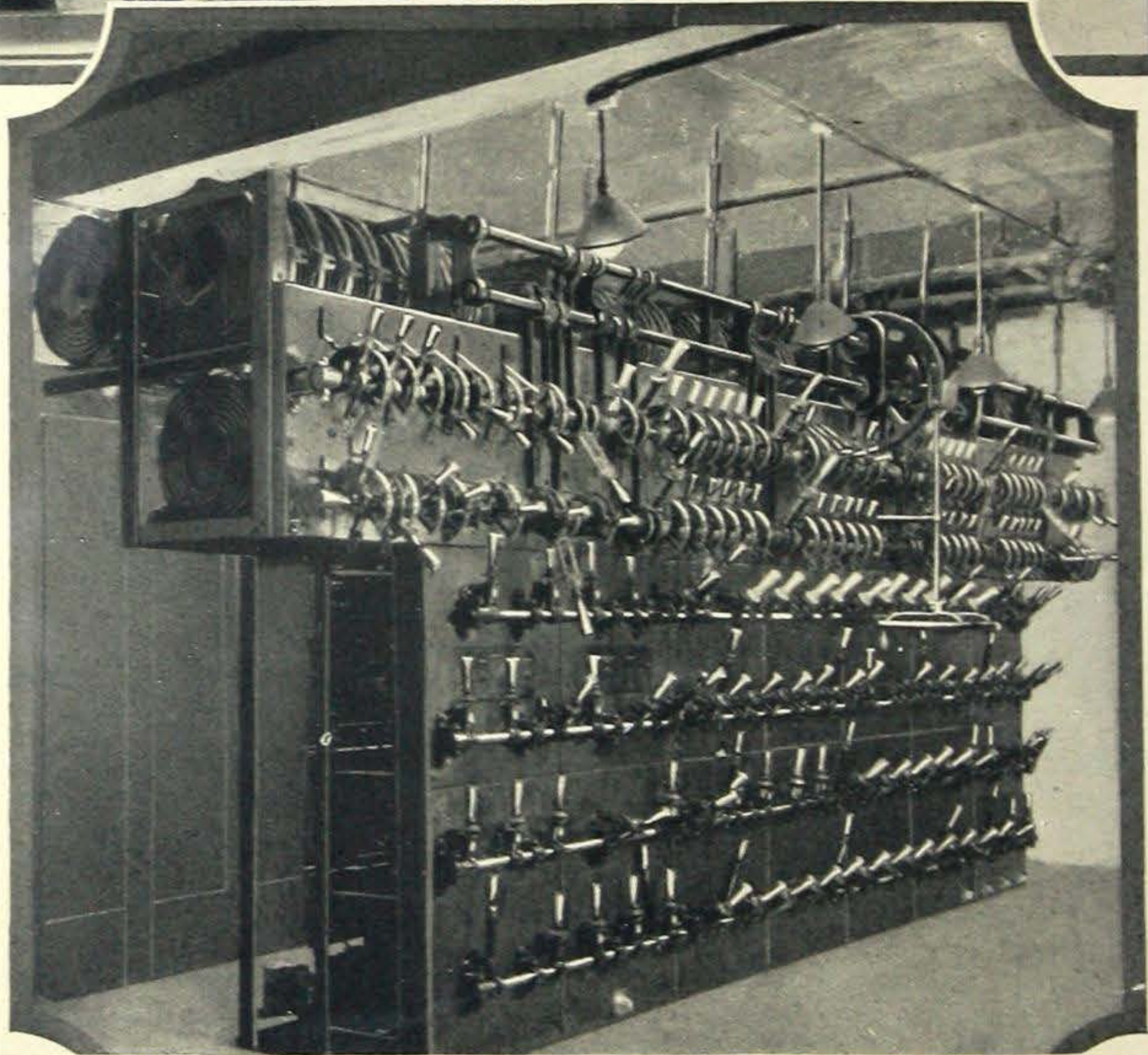

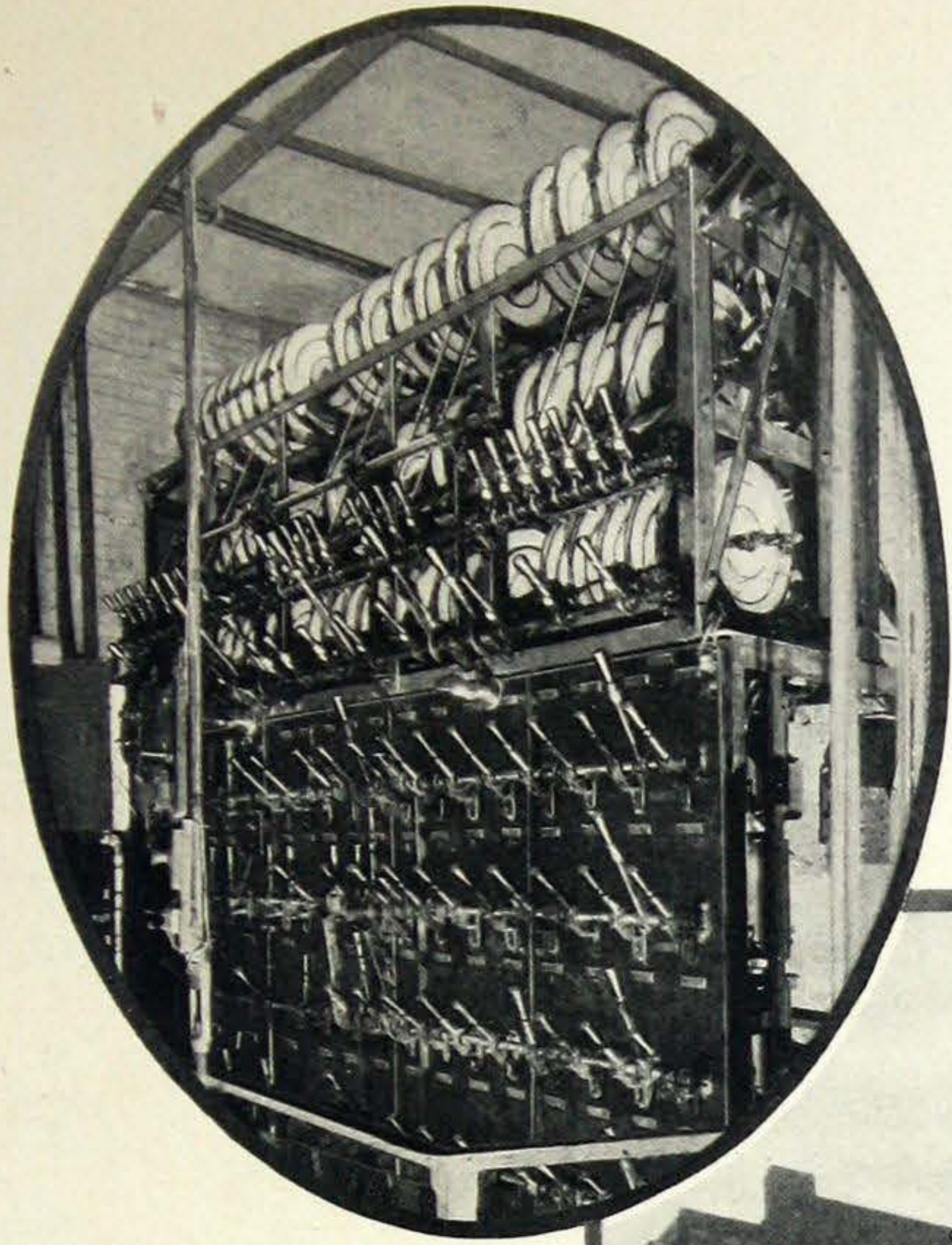

Nearly all of the prominent theatres on Broadway use Vitrohm Dimmer equipment for lighting effects. The Winter Garden and Rivoli are no exception. The partial list of Vitrohm installations on page 62 gives some idea of their universal application.

Vitrohm Dimmer equipment in the Winter Garden, New York.

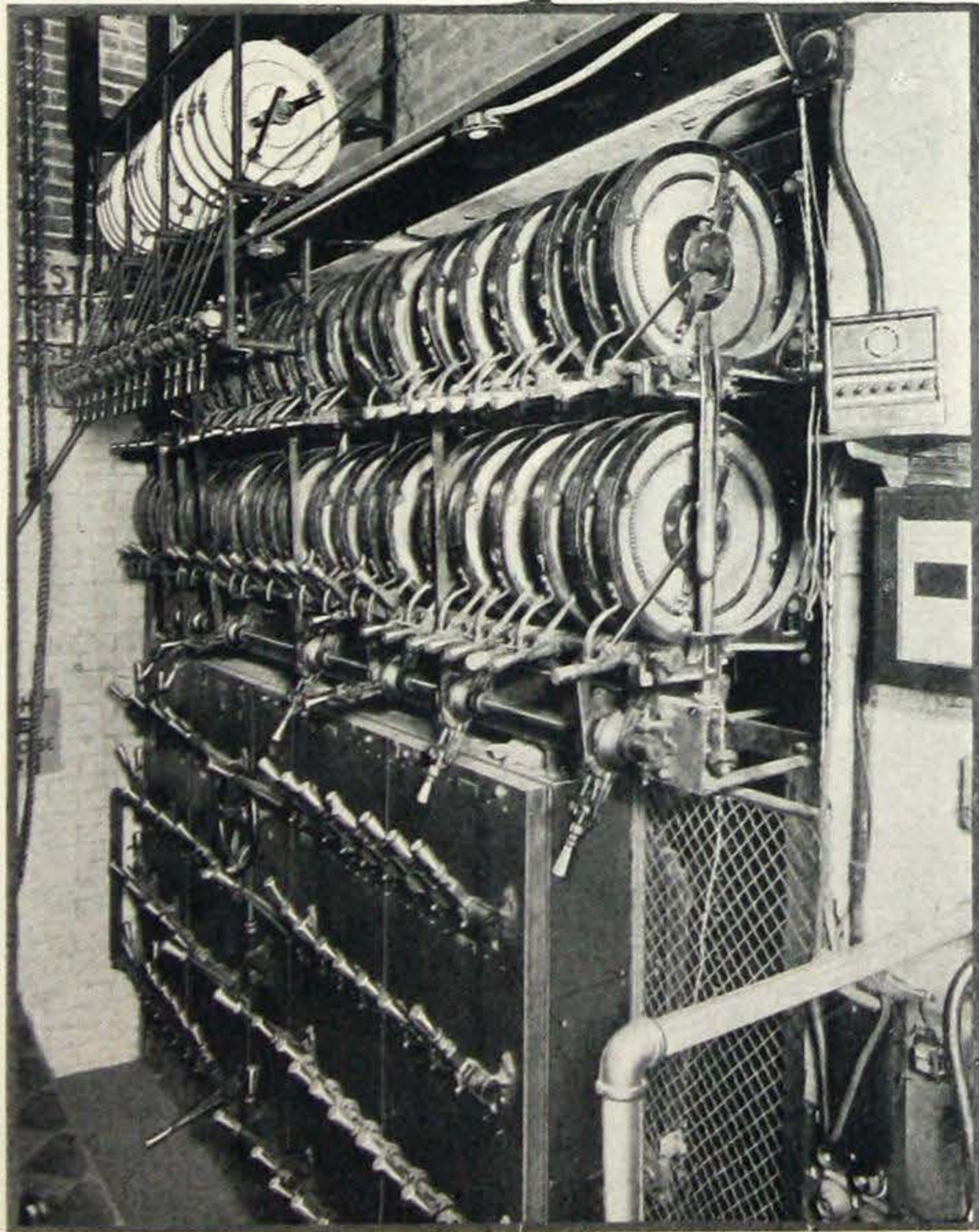

Two views of the Vitrohm Dimmerequipment in Rivoli Theatre.

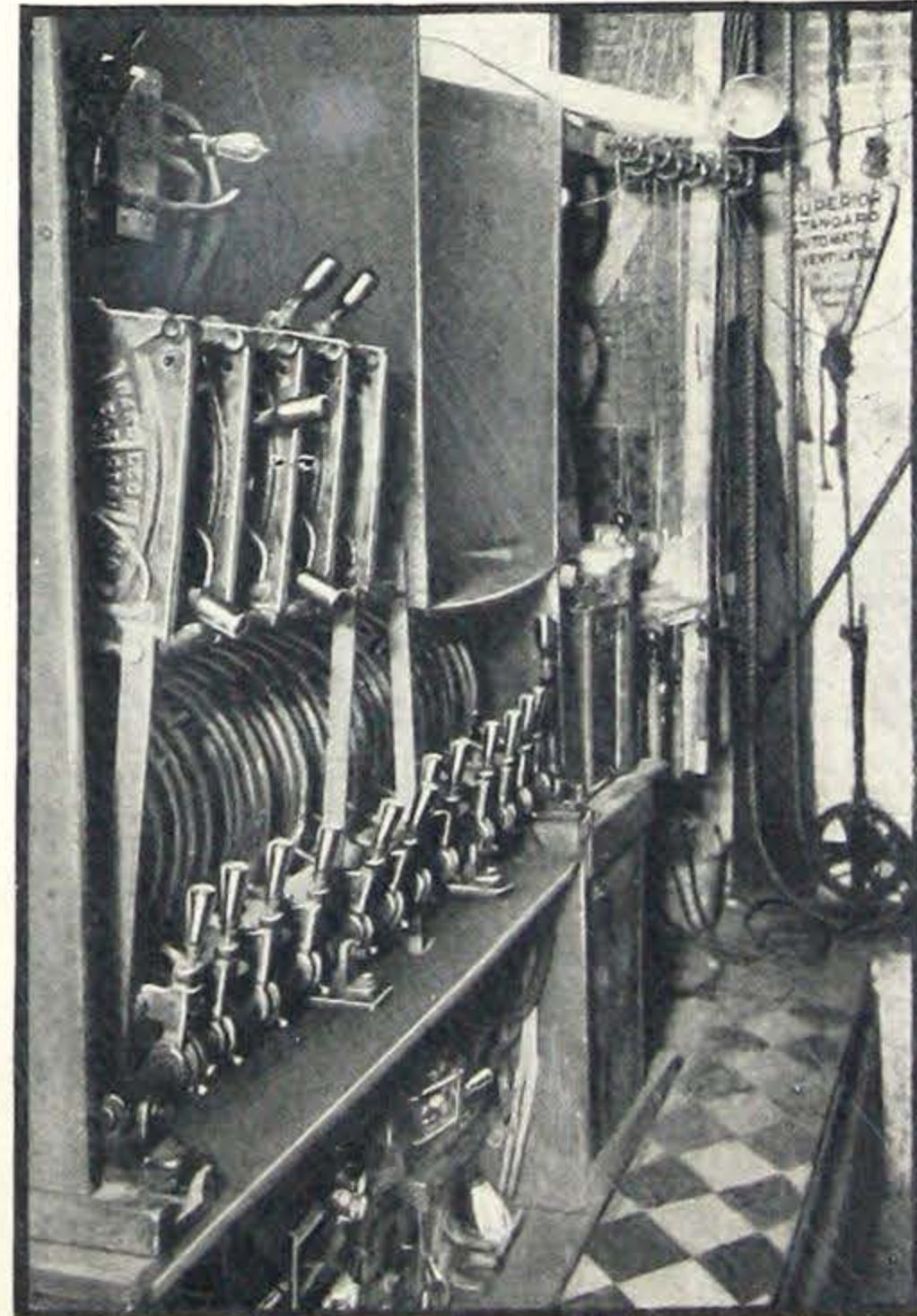

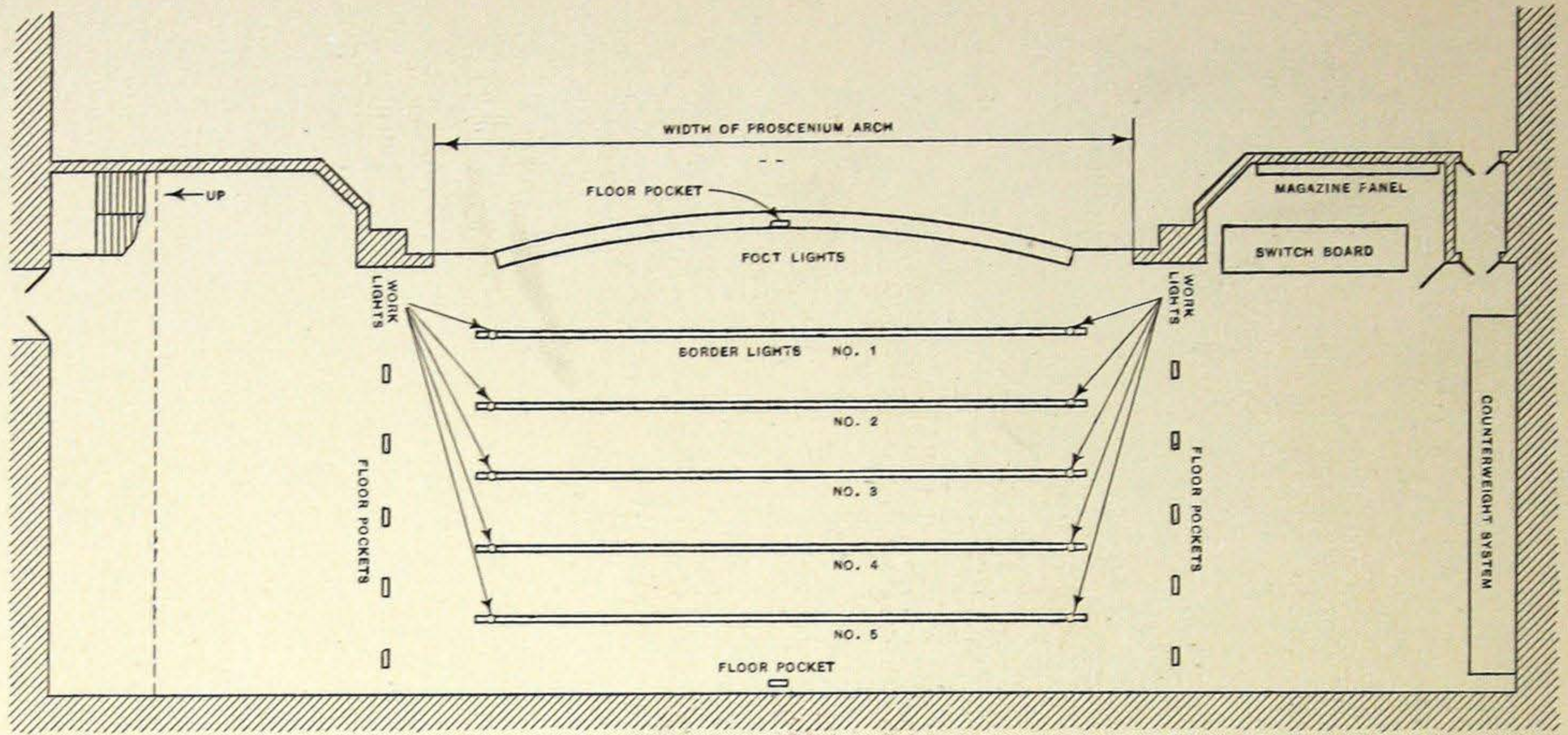

A typical floor plan for stage lighting

PORTABLE EQUIPMENT

Compactness and light weight of Vitrohm dimmers are of particular advantage to travelling or road shows when the desired lighting effects cannot be secured with the local equipment. Here and on the opposite page are shown several equipments provided for the purpose.

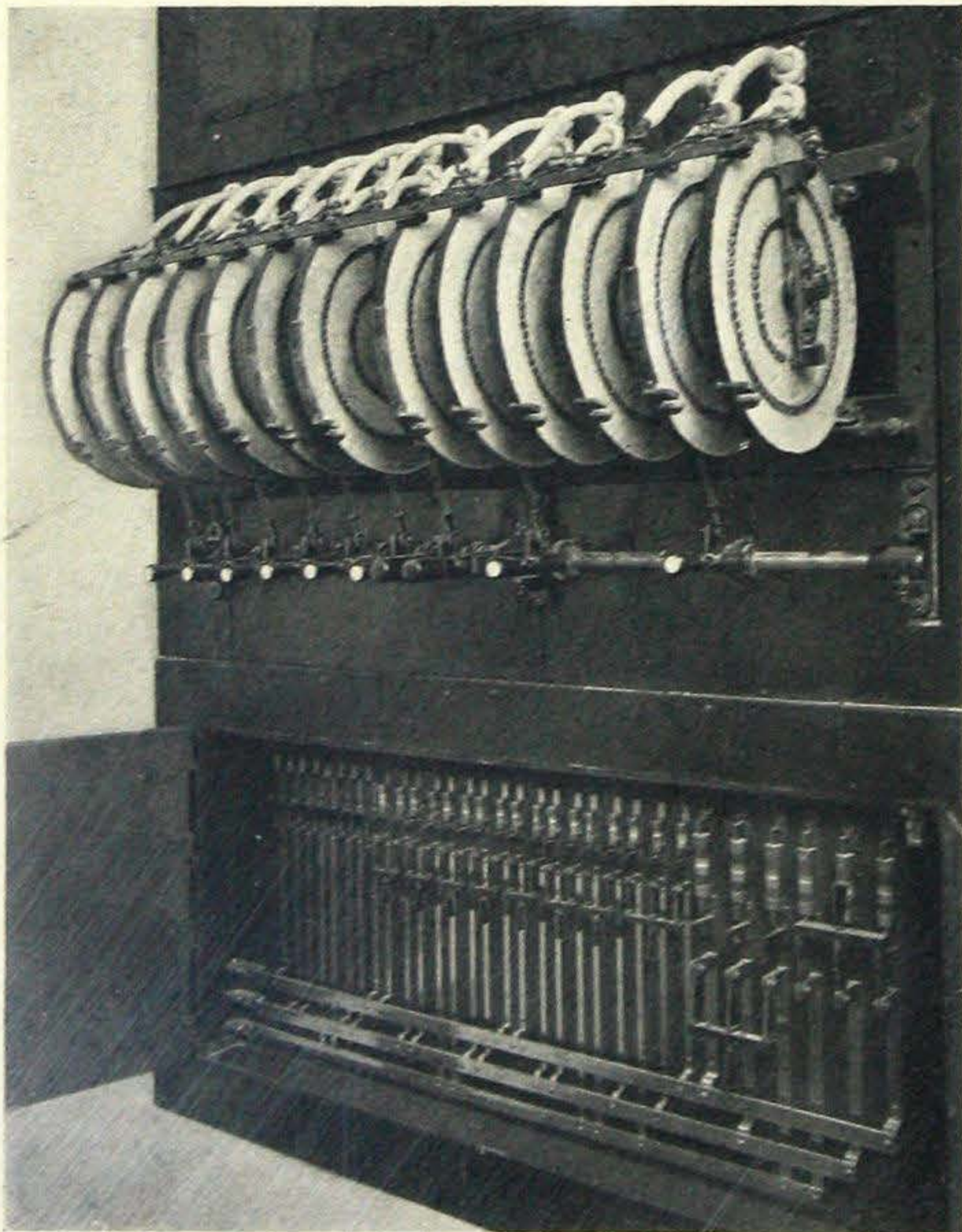

Vitrohm Dimmer equipment and switchboard used for controlling the lighting of the Auditorium of the Metropolitan Life Insurance Company, New York.

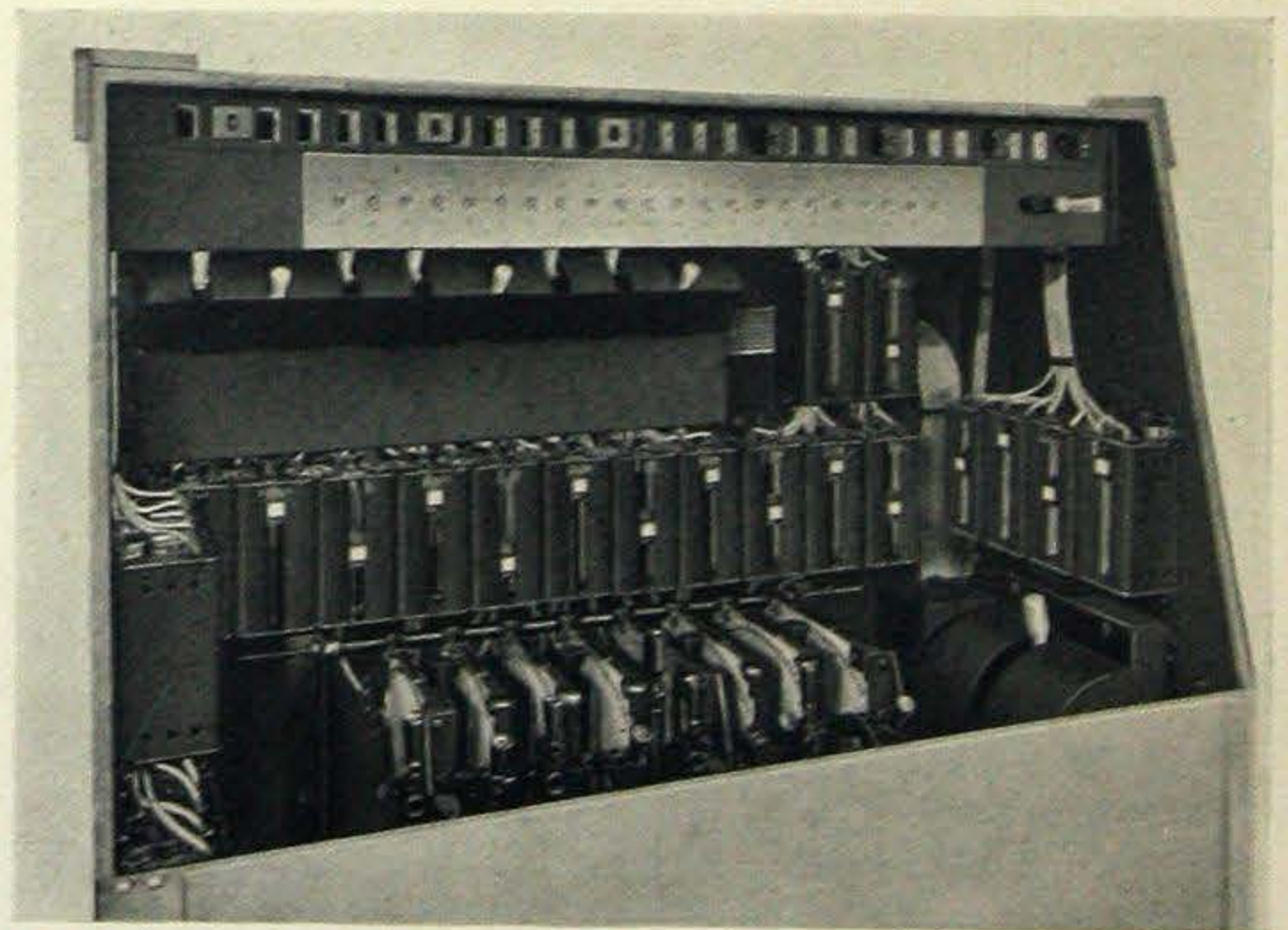

400-ampere Portable Dimmer equipment manufactured by the New York Calcium Light Company, using 8 standard rectangular Vitrohm plates and 18 slide type Vitrohm spotlight dimmers.



Portable Dimmer equipment made by James Pennefather, New York, using round type Vitrohm plates.

Portable Dimmer equipment made especially for the spectacular show, "Mecca," using Vitrohm round plates and Ward Leonard control levers on the switchboard.

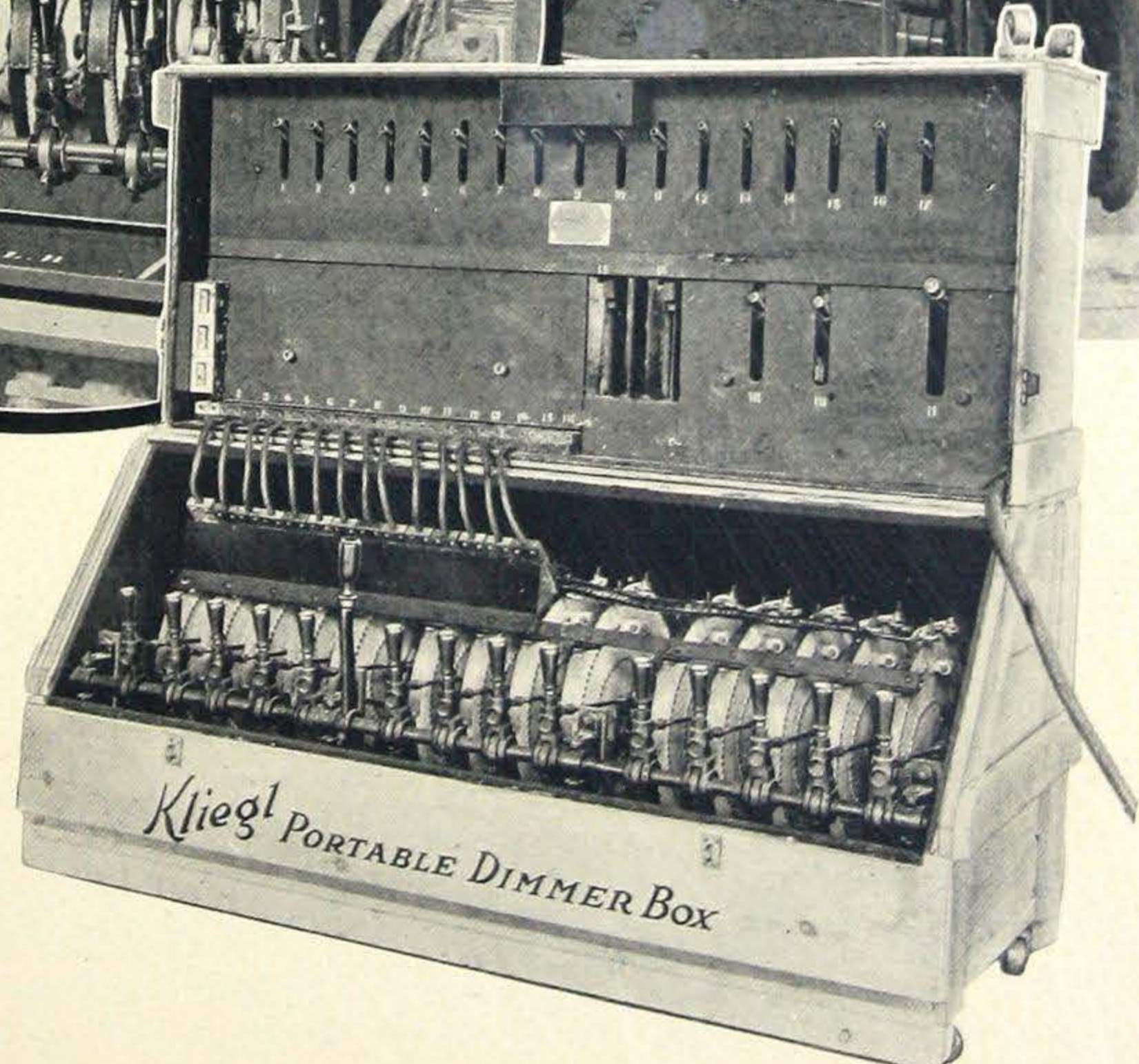
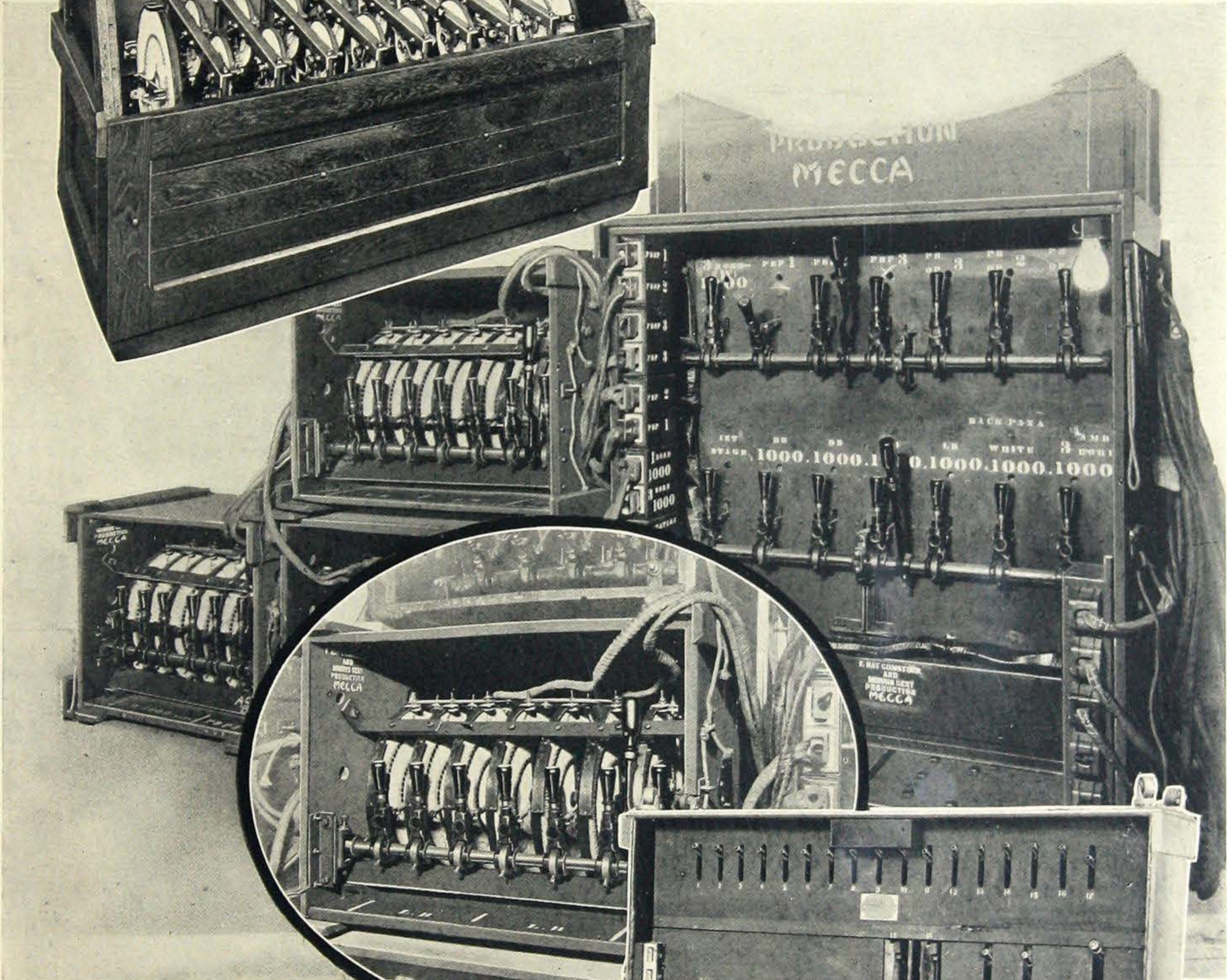

Portable Dimmer equipment made by Kliegl Bros., New York, using Vitrohm round plates.

PROJECTION LAMP CONTROL RHEOSTAT

(For 600 and 900-Watt Lamps)

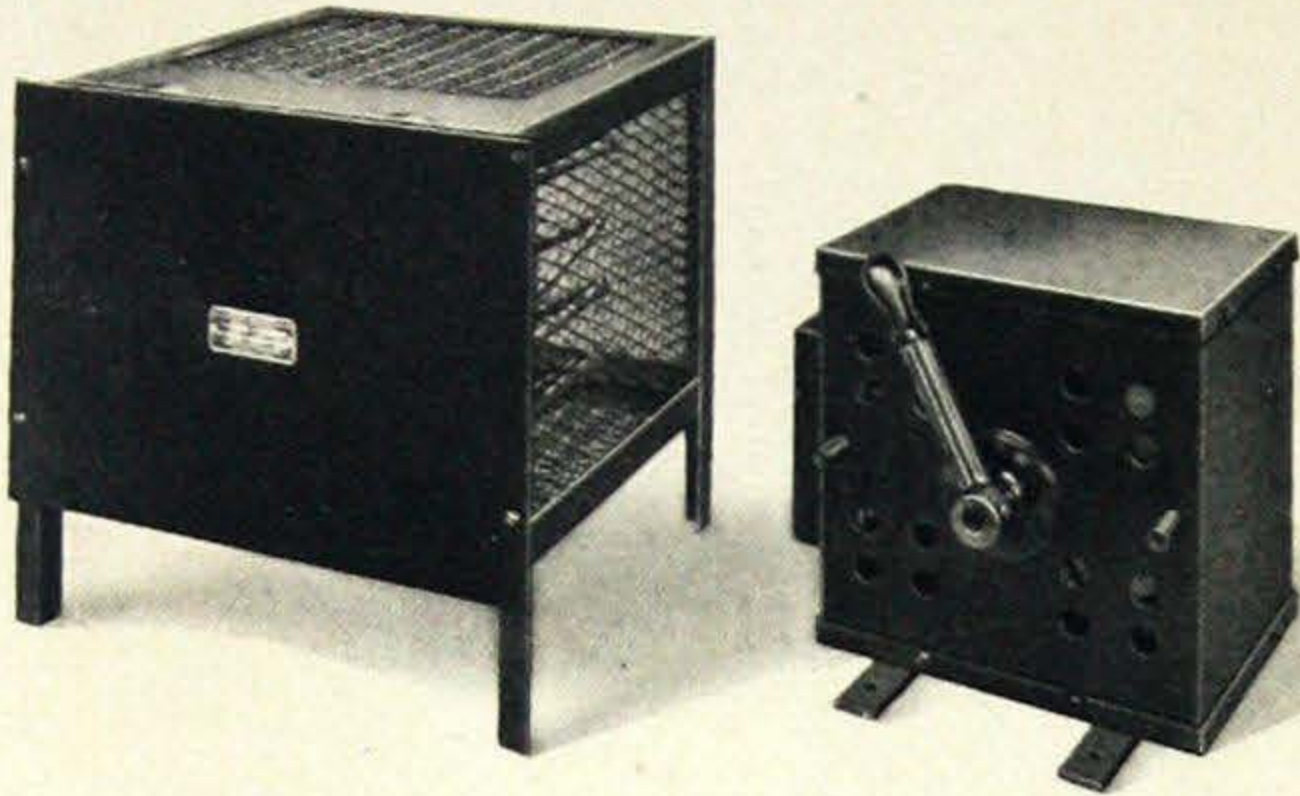

THE life and efficiency of a projection lamp depend on maintenance of the current supplied the lamp exactly in accordance with the rated current on which it was designed to operate.

To accomplish this a rheostat is required capable of reducing the line voltage to precisely the proper voltage needed to permit the proper amount of current to flow through the lamp.

The Ward Leonard Lamp Control Rheostat

is especially designed to serve this purpose with maximum dependability and convenience.

To reduce the line voltage to approximately that desired for the proper operation of the lamp a fixed resistance, made up of Ward Leonard Ribohm Resistor Units, is provided. These rigid, self-supporting units are made of metal ribbons, are very light in weight, are practically unbreakable, and have great capacity for heat radiation.

An adjustable resistance element, of Ward Leonard Vitrohm construction, permits close regulation of the lamp current. Initial current inrush is automatically limited sufficiently to assure slow heating of the lamp filament—a feature of substantial value in increasing the life of the lamp.

Ward Leonard Projection Lamp Control Rheostats can be used on either Direct or Alternating Current, and can be supplied for service on line voltages of 32 to 320 volts.

In common with all Ward Leonard apparatus the workmanship, finish and general appearance of this equipment fully accords with its superior efficiency in service.

MOTOR RHEOSTATS FOR BLOWER EQUIPMENT



D. C. Motor Starter

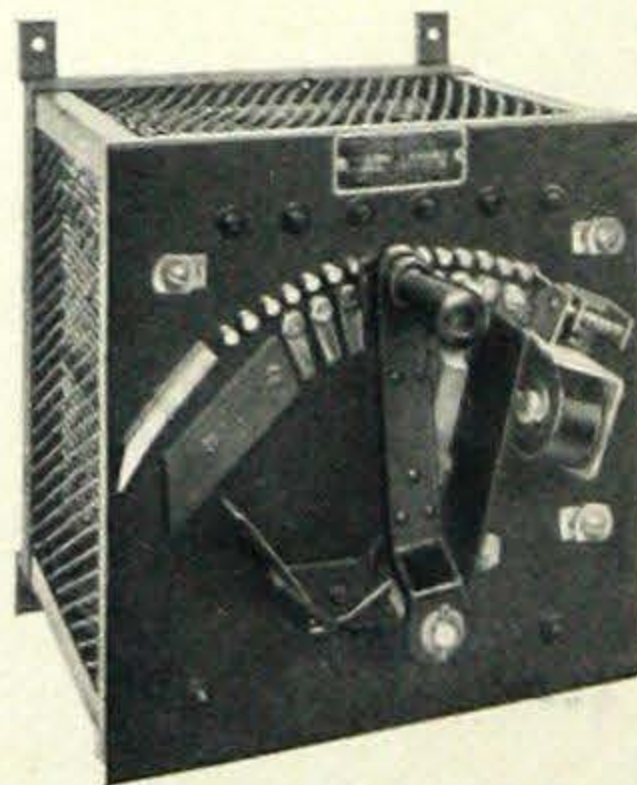

D. C. Motor Starter with 16 Points of Field Control.



A. C. Single-Phase Starter

RELIABLE motor starters for the control of motor-driven blowers for ventilating theatre auditoriums, motion picture projection booths, spotlight booths, etc., are essential to the proper operation of this important equipment.

Ward Leonard Motor Starters will be found perfectly adapted to this service and are available in types and sizes covering all requirements.

Ward Leonard Vitrohm and Ribohm Resistor Units, incorporated in all of these motor

starters, provide a resistance element (the heart of a motor starter) of great mechanical strength and heat radiating capacity—far superior to ordinary cast iron grids.

These features, combined with other points of great practical advantage, such as permanently efficient contactors, smooth-working of moving parts, and dust-proof construction, assure the easy, positive and dependable operation of this equipment.

PUSH BUTTON CONTACTOR

(For Organ Blower Motor)

A RELIABLE automatic starter for the remote control of theatre organ blower motors is a practically indispensable adjunct to the proper operation of such organs in the up-to-date theatre.

Ward Leonard Push Button Contactors of the type here illustrated are standard equipment for this service. Correct design, quality material, high grade workmanship—heavily insulated operating coils, liberal contact areas, dust-proof construction, thorough ventilation—Vitrohm Resistors. These are elements which assure the efficient performance of this highly important equipment.

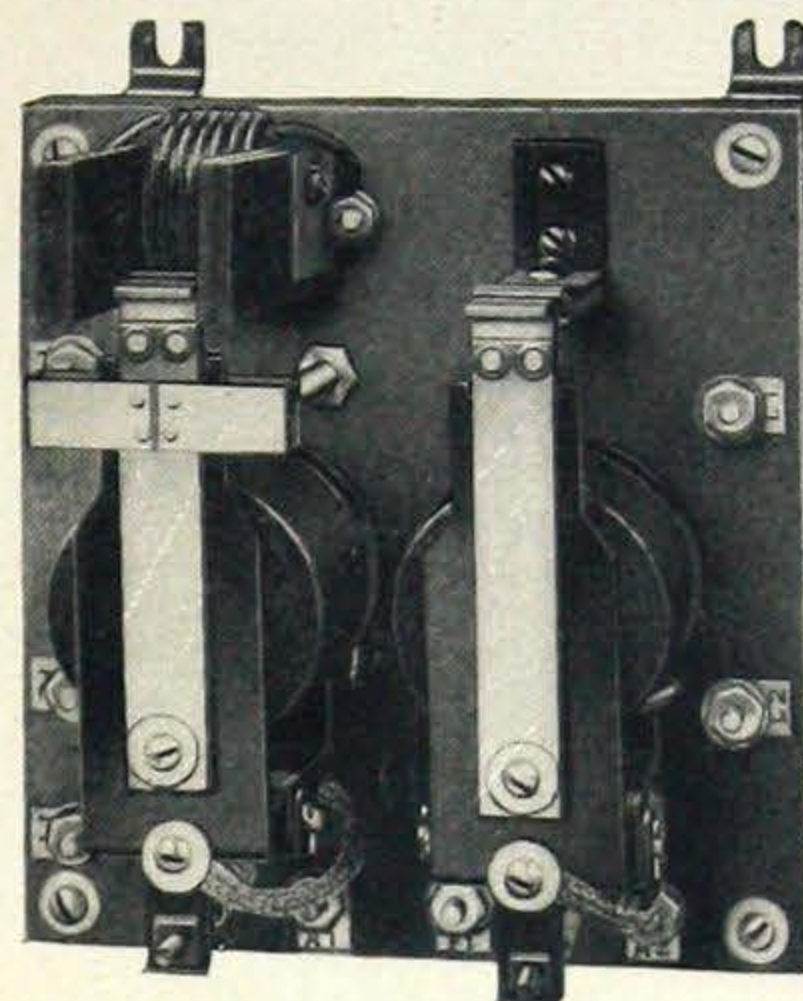

ARC CONTROL RHEOSTATS



EASY to operate. Dependable. Regulates closely over wide range. Mechanically strong. Will give long service under heavy duty. Low cost.

The perfect rheostat for motion picture, spotlight or arc control requirements.

Ward Leonard Arc Control Rheostats, equipped with Ward Leonard Vitrohm and Ribohm resistor units, weigh but half as much as ordinary cast iron grid series rheostats, and are practically trouble-proof. They are supplied in several special designs, respectively intended for picture arc control, for controlling spotlight in booth, for spotlight on stage, or to serve as generator ballast.

This equipment is widely used and recommended for such service in the theatrical field, and will be found definitely superior in point of service, first cost, or maintenance expense.

GENERATOR FIELD RHEOSTATS

THE motor generator set which supplies the energy for the motion picture machines and spotlights is generally supplied with a rheostat for field control. Ward Leonard Vitrohm Field Rheostats will be found exactly adapted to theatre needs in this service.

The Vitrohm construction of these rheostats is very similar to that described in connection with Ward Leonard Dimmer Plates pictured elsewhere in this book. Fire-proof, moisture-proof, non-absorbent vitreous enamel completely and permanently protects the resistance wire from oxidation or corrosion.

These rheostats are provided in sizes covering all usual ampere capacities, and in various types of control arrangement to suit requirements.

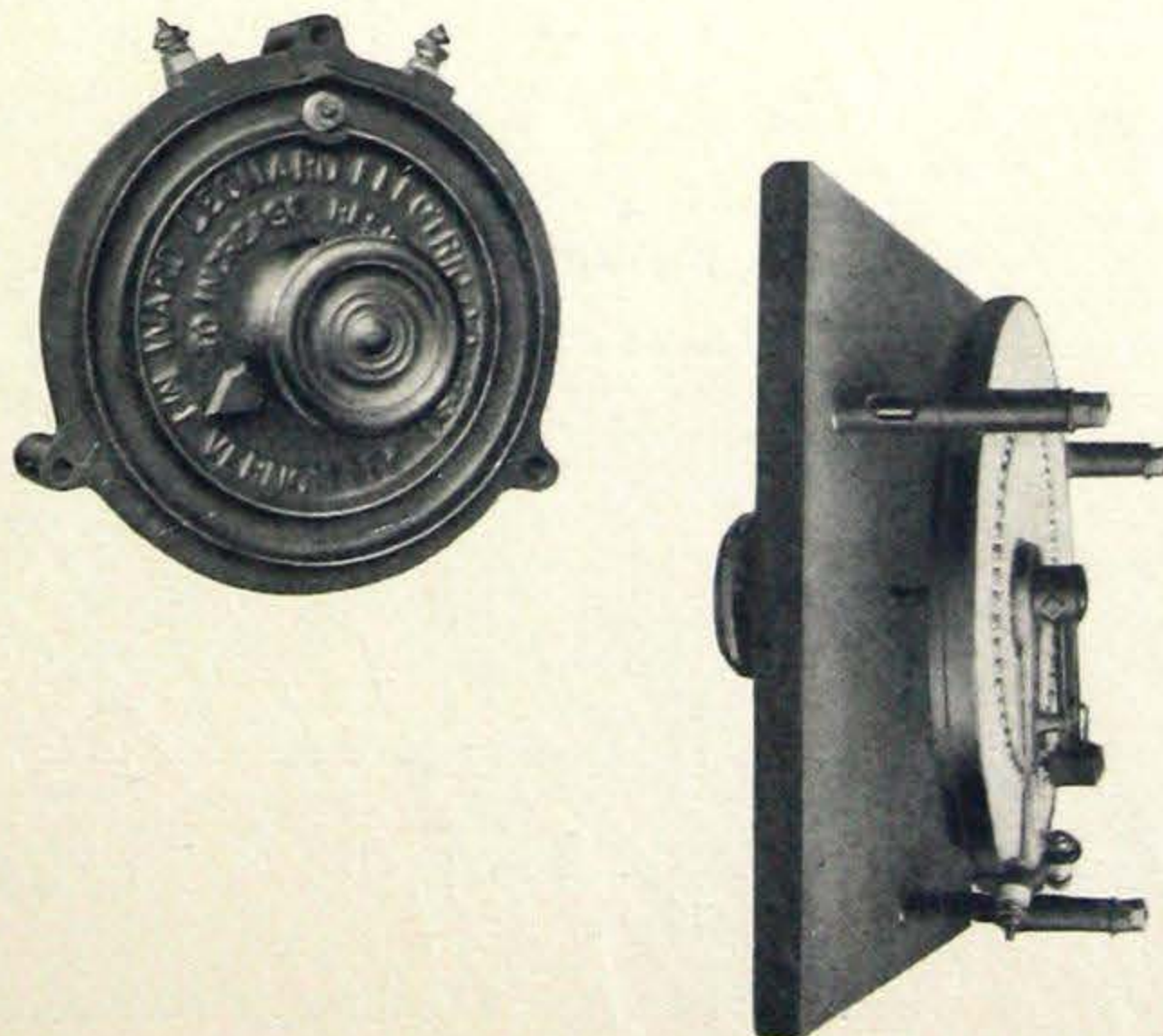

A Partial List of Ward Leonard Vitrohm Dimmer Installations

ARKANSAS Little Rock Little Rock Theatre	FLORIDA Miami Masonic Temple	KENTUCKY Covington St. Joseph School	<i>Buffalo</i> Gayety Theatre Shea's Opera House Statler Hotel Victoria Theatre	<i>Troy</i> Proctor's Theatre Strand Theatre Uniontown State Theatre White Plains Lynn Theatre Woodhaven, L. I. Roosevelt Theatre Yonkers Metro Theatre Orpheum Theatre Strand Theatre
CALIFORNIA Anaheim Anaheim Theatre Elks' Club	GEORGIA Savannah Masonic Temple	MARYLAND Baltimore Johns Hopkins H. S. Ford Theatre	<i>Cedarhurst, L. I.</i> Central Theatre	<i>Woodhaven, L. I.</i> Roosevelt Theatre
<i>Bakersfield</i> Hippodrome Theatre	ILLINOIS Champaign Virginia Theatre	MASSACHUSETTS Boston Fine Arts Theatre. Hollis St. Theatre Loew's State Thea. Selwyn Theatre	<i>Dunton, L. I.</i> Masonic Lodge	<i>Yonkers</i> Metro Theatre Orpheum Theatre Strand Theatre
<i>Eureka</i> Eureka Theatre	<i>Chicago</i> Aryan Grotto Temple Blue Island Masonic Temple	<i>Somerville</i> Central Theatre	<i>Forest Hills, L. I.</i> Globe Theatre	NORTH CAROLINA High Point High Point Theatre Lexington Lexington Theatre
<i>Fullerton</i> Masonic Hall	<i>Chicago</i> Central Park Thea. Chicago Theatre Columbia Theatre Cort Theatre Covent Garden Thea. Englewood Theatre Glickmans Palace Th. Grand Theatre Hamlin Ave. Thea. HumboldtParkLodge 813, A. F. & A. M. HumboldtParkLodge Commandery No. 79, K. T.	<i>Springfield</i> Poli Theatre	<i>Freeport, L. I.</i> Freeport Social Club	
<i>Glendale</i> Palace Grand Thea.	<i>Illinois Theatre</i> Lawndale Masonic Temple	MICHIGAN Detroit Capitol Theatre Gayety Theatre	<i>Hempstead, L. I.</i> Rivoli Theatre	
<i>Los Angeles</i> Arlington Theatre Belvedere Theatre Chottiner Theatre Circle Theatre Edison Club Room Graff Theatre Hotel Theatre Larchmont Theatre Le Conte, Jr., High School Loew's State Thea. McKinley High School McMurray Theatre Metropolitan Theatre Moneta Theatre John Muir High School Paramount Theatre Rivoli Theatre Sentuons High School Southout Theatre Temple Theatre Tivoli Theatre Tripoli Theatre Van Nuys Theatre Writers' Club	<i>Lawndale Theatre</i> Lincoln Tavern Logan Sq. Masonic Temple Lomax Theatre Marzano Dance Hall Midway Masonic Temple Opera Club Orchestra Hall Powers Theatre Rainbo Gardens Roosevelt Theatre Roseland-State Thea. St. Bernard Com- mandery No. 35, K. T.	<i>St. Louis</i> Shubert-Jefferson Gayety Theatre	<i>Jamaica, L. I.</i> Merrick Theatre Roseland Theatre	OHIO Akron Pythian Temple Cleveland Allen Theatre Municipal Hall Dayton National Theatre Niles Niles Theatre
<i>Monte Rio</i> Bohemian Grove	<i>Illinois Theatre</i> Lawndale Masonic Temple	MISSOURI Joplin Scottish Rites Cath'l	<i>Middletown</i> Middletown Theatre	
<i>Oakland</i> Fox-Oakland Theatre Masonic Temple	<i>Lawndale Theatre</i> Lincoln Tavern Logan Sq. Masonic Temple	<i>St. Louis</i> Shubert-Jefferson Gayety Theatre	<i>New Rochelle</i> High School Loew's Theatre	
<i>Ocean Park</i> Dome Theatre	<i>Lawndale Theatre</i> Lincoln Tavern Logan Sq. Masonic Temple	NEW JERSEY Asbury Park Main Theatre	<i>New York City</i> Belasco Theatre Blue Bird Dancing Century Theatre Clover Garden Cohan & Harris Thea. Cort Theatre Daly 63rd St. Theatre Empire Theatre Freeman Theatre 14th St. Theatre Hamilton Harlem Opera House Hippodrome Hotel Plaza Jefferson Theatre Keith's Colonial Keith's Royal Keith's 81st St. Thea. Liberty Theatre Loew's National Loew's 83rd St. Thea. Longacre Theatre Lyceum Theatre Marc Klaw Theatre Maxine Elliott Thea. New Winter Garden Palais Royal Playhouse Proctor's Theatre Rainbow Dancing Punch & Judy Thea. Regent Theatre Ritz Theatre Roosevelt Theatre Roseland Shubert Theatre Strand Theatre Tivoli Theatre	PENNSYLVANIA Braddock Capitol Theatre McKeesport Columbian Theatre Philadelphia Germantown Theatre Pittsburgh State Theatre Scranton Scranton Theatre
<i>Pasadena</i> Raymond Theatre	<i>Lawndale Theatre</i> Lincoln Tavern Logan Sq. Masonic Temple	<i>Jersey City</i> Heste Theatre or Ritz Rivoli Theatre State Theatre Twin Theatre	<i>New Rochelle</i> High School Loew's Theatre	
<i>Richmond</i> T & D Theatre	<i>Lawndale Theatre</i> Lincoln Tavern Logan Sq. Masonic Temple	<i>Lakewood</i> Lakewood Theatre Palace Theatre	<i>New York City</i> Belasco Theatre Blue Bird Dancing Century Theatre Clover Garden Cohan & Harris Thea. Cort Theatre Daly 63rd St. Theatre Empire Theatre Freeman Theatre 14th St. Theatre Hamilton Harlem Opera House Hippodrome Hotel Plaza Jefferson Theatre Keith's Colonial Keith's Royal Keith's 81st St. Thea. Liberty Theatre Loew's National Loew's 83rd St. Thea. Longacre Theatre Lyceum Theatre Marc Klaw Theatre Maxine Elliott Thea. New Winter Garden Palais Royal Playhouse Proctor's Theatre Rainbow Dancing Punch & Judy Thea. Regent Theatre Ritz Theatre Roosevelt Theatre Roseland Shubert Theatre Strand Theatre Tivoli Theatre	
<i>San Francisco</i> Castro Theatre Excelsior Theatre Fox Theatre Granada Theatre Palace Hotel Rialto Theatre	<i>Lawndale Theatre</i> Lincoln Tavern Logan Sq. Masonic Temple	<i>Montclair</i> Claridge Theatre	<i>New York City</i> Belasco Theatre Blue Bird Dancing Century Theatre Clover Garden Cohan & Harris Thea. Cort Theatre Daly 63rd St. Theatre Empire Theatre Freeman Theatre 14th St. Theatre Hamilton Harlem Opera House Hippodrome Hotel Plaza Jefferson Theatre Keith's Colonial Keith's Royal Keith's 81st St. Thea. Liberty Theatre Loew's National Loew's 83rd St. Thea. Longacre Theatre Lyceum Theatre Marc Klaw Theatre Maxine Elliott Thea. New Winter Garden Palais Royal Playhouse Proctor's Theatre Rainbow Dancing Punch & Judy Thea. Regent Theatre Ritz Theatre Roosevelt Theatre Roseland Shubert Theatre Strand Theatre Tivoli Theatre	SOUTH CAROLINA Greensburgh National Theatre
<i>Santa Clara</i> Santa Clara College	<i>Lawndale Theatre</i> Lincoln Tavern Logan Sq. Masonic Temple	<i>Newark</i> Shubert Rialto Central Theatre Rivoli	<i>New York City</i> Belasco Theatre Blue Bird Dancing Century Theatre Clover Garden Cohan & Harris Thea. Cort Theatre Daly 63rd St. Theatre Empire Theatre Freeman Theatre 14th St. Theatre Hamilton Harlem Opera House Hippodrome Hotel Plaza Jefferson Theatre Keith's Colonial Keith's Royal Keith's 81st St. Thea. Liberty Theatre Loew's National Loew's 83rd St. Thea. Longacre Theatre Lyceum Theatre Marc Klaw Theatre Maxine Elliott Thea. New Winter Garden Palais Royal Playhouse Proctor's Theatre Rainbow Dancing Punch & Judy Thea. Regent Theatre Ritz Theatre Roosevelt Theatre Roseland Shubert Theatre Strand Theatre Tivoli Theatre	RHODE ISLAND Newport Newport Theatre Providence Palace Dance Hall
<i>San Pedro</i> Dodson Theatre	<i>Lawndale Theatre</i> Lincoln Tavern Logan Sq. Masonic Temple	<i>New Brunswick</i> Opera House Reade Theatre Rivoli Theatre	<i>New York City</i> Belasco Theatre Blue Bird Dancing Century Theatre Clover Garden Cohan & Harris Thea. Cort Theatre Daly 63rd St. Theatre Empire Theatre Freeman Theatre 14th St. Theatre Hamilton Harlem Opera House Hippodrome Hotel Plaza Jefferson Theatre Keith's Colonial Keith's Royal Keith's 81st St. Thea. Liberty Theatre Loew's National Loew's 83rd St. Thea. Longacre Theatre Lyceum Theatre Marc Klaw Theatre Maxine Elliott Thea. New Winter Garden Palais Royal Playhouse Proctor's Theatre Rainbow Dancing Punch & Judy Thea. Regent Theatre Ritz Theatre Roosevelt Theatre Roseland Shubert Theatre Strand Theatre Tivoli Theatre	TENNESSEE Chattanooga Central High School
<i>Santa Rosa</i> Cline Theatre	<i>Lawndale Theatre</i> Lincoln Tavern Logan Sq. Masonic Temple	<i>Paterson</i> Lyceum Theatre Paterson Masonic Lodge	<i>New York City</i> Belasco Theatre Blue Bird Dancing Century Theatre Clover Garden Cohan & Harris Thea. Cort Theatre Daly 63rd St. Theatre Empire Theatre Freeman Theatre 14th St. Theatre Hamilton Harlem Opera House Hippodrome Hotel Plaza Jefferson Theatre Keith's Colonial Keith's Royal Keith's 81st St. Thea. Liberty Theatre Loew's National Loew's 83rd St. Thea. Longacre Theatre Lyceum Theatre Marc Klaw Theatre Maxine Elliott Thea. New Winter Garden Palais Royal Playhouse Proctor's Theatre Rainbow Dancing Punch & Judy Thea. Regent Theatre Ritz Theatre Roosevelt Theatre Roseland Shubert Theatre Strand Theatre Tivoli Theatre	TEXAS Dallas Loew's Theatre
CONNECTICUT Bridgeport Poli Theatre	<i>Lawndale Theatre</i> Lincoln Tavern Logan Sq. Masonic Temple	<i>Trenton</i> Capitol Theatre Main Theatre	<i>New York City</i> Belasco Theatre Blue Bird Dancing Century Theatre Clover Garden Cohan & Harris Thea. Cort Theatre Daly 63rd St. Theatre Empire Theatre Freeman Theatre 14th St. Theatre Hamilton Harlem Opera House Hippodrome Hotel Plaza Jefferson Theatre Keith's Colonial Keith's Royal Keith's 81st St. Thea. Liberty Theatre Loew's National Loew's 83rd St. Thea. Longacre Theatre Lyceum Theatre Marc Klaw Theatre Maxine Elliott Thea. New Winter Garden Palais Royal Playhouse Proctor's Theatre Rainbow Dancing Punch & Judy Thea. Regent Theatre Ritz Theatre Roosevelt Theatre Roseland Shubert Theatre Strand Theatre Tivoli Theatre	VIRGINIA Winchester Winchester Theatre Handley School
<i>Hartford</i> Poli Theatre	<i>Lawndale Theatre</i> Lincoln Tavern Logan Sq. Masonic Temple	<i>West Hoboken</i> Roosevelt Theatre	<i>New York City</i> Belasco Theatre Blue Bird Dancing Century Theatre Clover Garden Cohan & Harris Thea. Cort Theatre Daly 63rd St. Theatre Empire Theatre Freeman Theatre 14th St. Theatre Hamilton Harlem Opera House Hippodrome Hotel Plaza Jefferson Theatre Keith's Colonial Keith's Royal Keith's 81st St. Thea. Liberty Theatre Loew's National Loew's 83rd St. Thea. Longacre Theatre Lyceum Theatre Marc Klaw Theatre Maxine Elliott Thea. New Winter Garden Palais Royal Playhouse Proctor's Theatre Rainbow Dancing Punch & Judy Thea. Regent Theatre Ritz Theatre Roosevelt Theatre Roseland Shubert Theatre Strand Theatre Tivoli Theatre	WASHINGTON Seattle Garfield High School Hotel Theatre Holy Rosary School St. John's Parish School
<i>Meriden</i> Community Theatre	<i>Lawndale Theatre</i> Lincoln Tavern Logan Sq. Masonic Temple	<i>Brooklyn</i> Bay Ridge Theatre Bensonhurst Thea. Capitol Theatre Commodore Theatre Glenwood Theatre Kismet Temple Meserole Theatre Midwood Theatre Miller Theatre B. F. Moss Theatre National Theatre Premier Theatre	<i>New York City</i> Belasco Theatre Blue Bird Dancing Century Theatre Clover Garden Cohan & Harris Thea. Cort Theatre Daly 63rd St. Theatre Empire Theatre Freeman Theatre 14th St. Theatre Hamilton Harlem Opera House Hippodrome Hotel Plaza Jefferson Theatre Keith's Colonial Keith's Royal Keith's 81st St. Thea. Liberty Theatre Loew's National Loew's 83rd St. Thea. Longacre Theatre Lyceum Theatre Marc Klaw Theatre Maxine Elliott Thea. New Winter Garden Palais Royal Playhouse Proctor's Theatre Rainbow Dancing Punch & Judy Thea. Regent Theatre Ritz Theatre Roosevelt Theatre Roseland Shubert Theatre Strand Theatre Tivoli Theatre	WISCONSIN Madison Orpheum Theatre
<i>New London</i> Opera House	<i>Lawndale Theatre</i> Lincoln Tavern Logan Sq. Masonic Temple	<i>Babylon, L. I.</i> Capitol Theatre	<i>New York City</i> Belasco Theatre Blue Bird Dancing Century Theatre Clover Garden Cohan & Harris Thea. Cort Theatre Daly 63rd St. Theatre Empire Theatre Freeman Theatre 14th St. Theatre Hamilton Harlem Opera House Hippodrome Hotel Plaza Jefferson Theatre Keith's Colonial Keith's Royal Keith's 81st St. Thea. Liberty Theatre Loew's National Loew's 83rd St. Thea. Longacre Theatre Lyceum Theatre Marc Klaw Theatre Maxine Elliott Thea. New Winter Garden Palais Royal Playhouse Proctor's Theatre Rainbow Dancing Punch & Judy Thea. Regent Theatre Ritz Theatre Roosevelt Theatre Roseland Shubert Theatre Strand Theatre Tivoli Theatre	WYOMING Cheyenne Masonic Temple
DELAWARE Wilmington Dupont Theatre	IOWA Davenport New Theatre Des Moines Roosevelt High School Ottumwa High School		<i>New York City</i> Belasco Theatre Blue Bird Dancing Century Theatre Clover Garden Cohan & Harris Thea. Cort Theatre Daly 63rd St. Theatre Empire Theatre Freeman Theatre 14th St. Theatre Hamilton Harlem Opera House Hippodrome Hotel Plaza Jefferson Theatre Keith's Colonial Keith's Royal Keith's 81st St. Thea. Liberty Theatre Loew's National Loew's 83rd St. Thea. Longacre Theatre Lyceum Theatre Marc Klaw Theatre Maxine Elliott Thea. New Winter Garden Palais Royal Playhouse Proctor's Theatre Rainbow Dancing Punch & Judy Thea. Regent Theatre Ritz Theatre Roosevelt Theatre Roseland Shubert Theatre Strand Theatre Tivoli Theatre	CANADA Toronto Allen Theatre Univ. of Toronto Winnipeg Gayety Theatre

There are hundreds of others (installed throughout the country during the past twenty years) that are proving Vitrohm Dimmers are truly Continuous Duty Dimmers.

[BLANK PAGE]



CCA

[BLANK PAGE]



CCA



